

WOODGREEN: MODULAR OUTDOOR FURNITURE

Designed by
EMILIANA DESIGN STUDIO



TECHNICAL SPECIFICATIONS

CONTAINER

- Made of medium density polyethylene.
- Raw material with coloration prior to its utilization.
- Pieces manufactured by rotational molding in environmental pressure and temperature of 250 ° to 280 °.
- Because of this manufacturing system, products achieve a high resistance to breakage and impact.
- Thickness of 3 mm. (approximately) around the entire perimeter.

COVER

- Manufactured with stainless Steel sheet of 2mm and 4mm thick.
- Manufactured and finished by profesionales specialized in this type of technology to ensure a perfect finish.
- Available in 4 colors: NEGRO, BLANCO, KAKI, GRANATE

WOODEN SEAT AND FRAME

Iroko wooden slat 44mm thick, available in two finishes. Natural and tinted wood treated to resist outdoor.

INSTALLATION

The planter bench model is delivered separately in two parts to optimize transport space. Both parts are easily assembled by the end user without tools needed. If, once installed, you want to change the location of a module, planter + bench, it will be necessary to separate both parts to reduce the weight and transport them easily.

DIMENSIONS

DIMENSIONS SIT CUBE 60x60x45

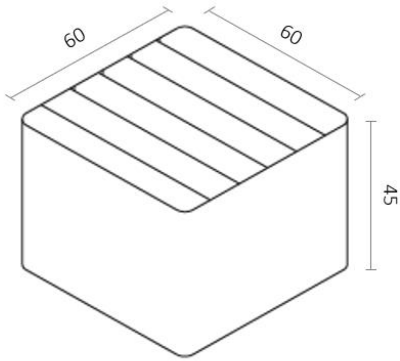

DIMENSIONS PLANTER 60x60x45

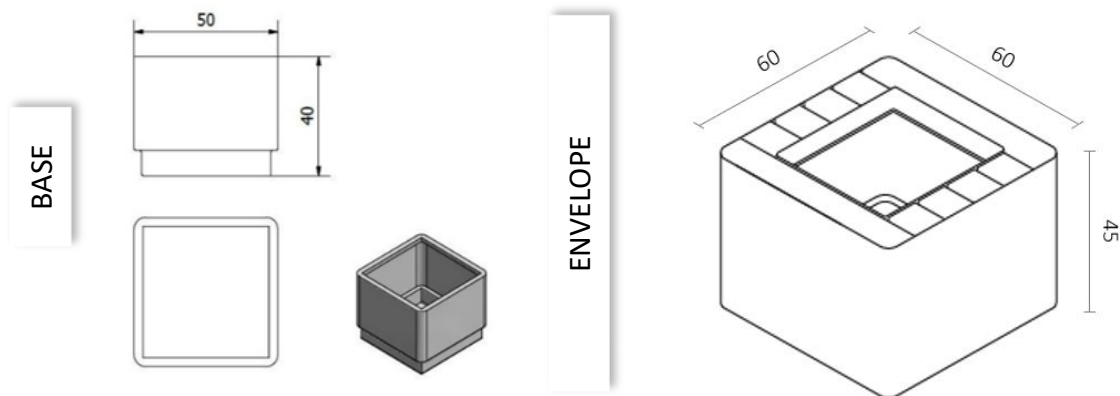

DIMENSIONS BENCH-PLANTER 170x60x45

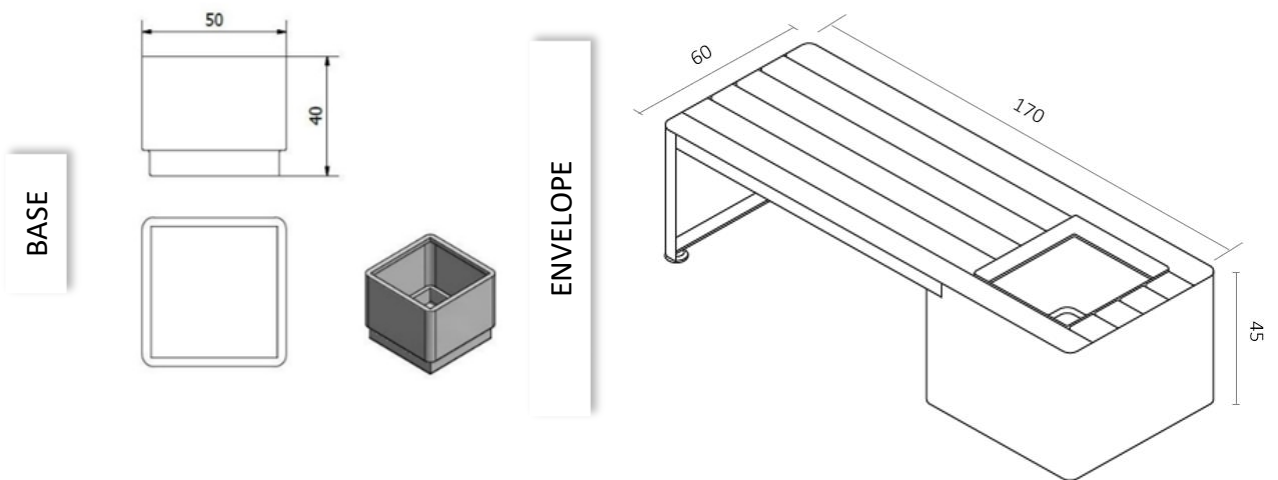

FINISHES

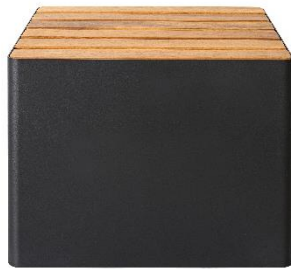

NATURAL IROKO



DARK IROKO



BLACK



WHITE



GARNET



KAKI

TECHNICAL DESCRIPTION – PATENTED SYSTEM HOBBY FLOWER

COMPONENTS:

1. Container
2. Separator
3. Tubs
4. Water indicator bar
5. Wicks
6. Drainage
7. Wheels



CONTAINER

Medium Density Polyethylene manufactured by rotational molding. This manufacturing system has the disadvantage of being much slower than the "injected" system (each molded takes between 20 and 30 minutes), but has the great advantage that the plastic molecules are subject to such high temperatures (only 250° - 280°) or any pressure which, with the slowness of the process, allows the molecules to form natural chains intertwined that gives a high resistance to breakage, making it almost unbreakable because they have no internal stresses.

We use molds of stainless steel, with brushed mirror inside to achieve a matte finish on the outer face of the cuvette.

Rotational molding system allows manufacturing parts and forms profiles that are almost impossible to manufacture by injection system.

Designing the shape of the container allows making as much as conic frustum holes as its need for the optional accommodation of wheels and also as a support for the spacer which is then applied in its upper surface. We mark the surface which is intended to contain the reserve of water and air through a perimeter somewhat lower all around.

There is about 3cms plane into the bucket at the top the of height of the tank, just up to the space for containing the drain, soil and plants and then a stud, approximately 2 cms in vertically downward. This form gives us a great nerve that helps the tank to be indeformable and very resistant.

This termination described in the top of the bucket, allows to catch and handle always taking it by this nerves, whether the Hydroplanter is empty, or as if it's planted and also if it carries on it one of the many decorative envelopes.

SEPARATOR

Extruded polystyrene sheet from 2,5 to 5 mm thick that is used for separating the area of the water reservoir with the upper one which contains the drainage and substrate with plants.

The separator has lots of small holes for placing a web of wicks that transport water from the reservoir to the drainage area, and two larger diameter holes for fitting the two tubs.

TUBS

Manufactured with polystyrene by blowing system. Each hydroplanter has two tubs and by simple pressure on the two holes of the separator you can attach them.

Both have the same shape and can be used interchangeably: one for filling water reserve and for ventilation and the other for support and guidance with the water level indicator of the reserve and also for ventilation.

We emphasize the usefulness of ventilation because, being two tubes that go into each planter, through them gets established a mini airstream that oxygenates the water deposited in the reserve, preventing spoilage. Through the small holes provided in the separator the wicks don't clog completely, allowing the deepest roots to find a rich oxygen atmosphere which is constantly regenerating.

WATER INDICATOR BAR

Constituted by an extruded plastic rod, a cap (with holes) for holding the tube in which inside slides a buoy that floats on the water reserve. This buoy/plastic float is manufactured by blowing and hermetically sealed.

When filling with water the area for reservation by one of the tubes, on the other tube goes up the float with its rod grey at the top showing what is considered ideal water level. From where the water level could exceed the separator, appears the red colored rod, which means that from this level of water can be harmful for the proper functioning of the system.

The use of the water level indicator is strictly limited to know when we have filled the water reservoir to the appropriate level. We should do this filling of the reserve only four times a year.

Although, a few days after filling the water reservoir, the level indicator is at its minimum height, does not mean that you need to replenish the reserve. We must wait to the moment that it's indicated (only 4 times

a year). When the level goes down does not mean that the plants have absorbed all the water, this means that has risen by capillary action through the wick. The drainage has permeated through and the substrate is ascending, but the plants will absorb the water in small particles (moisture) when it needs it.

Is also interesting that the space allocated to contain the water remains empty as long as possible because while the water does not occupy itself, the tank is continuously full of regenerated and available air and oxygen.

WICK

It is the means used for internal transport of water from the space allocated to the reserve until the top part of the separator where drainage gets soak. It's inserted through the small holes that the separator has, leaving its terminals inside the bucket to absorb all the water that is deposited on the tank.

It is composed of two different materials: an interior one consisting in highly absorbent natural fibers and an outer one made of synthetic fiber braided with high strength wrapping the interior, but not preventing its absorption work.

DRAINAGE

For making a good drainage, we use volcanic lava to the appropriate particle size adequate to the spaces of the gaps between the small holes of the separator and the wicks that go through with them.

Drainage utilities are three:

- 1) Makes that the substrate used doesn't get clumped against the upper surface of the separator.
- 2) To absorb and retain water that wicks are carrying to transfer it to the substrate that has thereon.
- 3) To act as a filter when once a month we water slightly above the substrate surface and prevent that the irrigation water used in the upper part pulls the substrate to the lower zone which is destined for containing the water reservoir.

For all the above it is clear that to take care properly of the plants located in the Hydroplanter we must perform two types of irrigation:

- "4 times a year" to fill the water reservoir until the Water Indicator Bar is red.

- "Once a month" to make a slight watering top of the substrate, leaving the amount of water used to the discretion of the person attending the plants, only to moisten the top that gets dry for the environment and to help the good development of small plants.

WHEELS

Excepted models using 65x25x35 cm, 100x25x35 cm and Ø 35cm base, the special HOBBY FLOWER wheels can be mounted on all other models and placed in the troco-conical holes they have for this purpose, in the lower part of the bases.

The main and rolling body is made from high strength bakelite, with two independent contact points with the floor and with a special design to avoid the entrainment of carpet threads. Each wheel is encased in a stamped sheet metal housing, made of stainless steel, the shape and size of the truncated-tapered holes in the base.