

VITAL ecus

Fabricamos mobiliario para facilitarle el equipamiento de sus espacios.

Cada uno de nuestros equipos está diseñado para desempeñar una función y rendimiento optimizado.

Sistemas de descanso eficientes, resolutivos e increíblemente fáciles de usar.

Nous fabriquons du mobilier pour faciliter l'agencement de vos espaces.

Chacun de nos équipements est conçu pour exécuter une fonction et un rendement optimisé.

Nos systèmes de couchage sont efficaces, opérationnels et incroyablement facile à utiliser.

We manufacture furniture to provide equipment for your contract space.

Each of our furnishings is designed to accomplish a functional and optimized performance.

Efficient resting equipments, problem-solving and incredibly easy to use.

6 **Blezz**

10 **Canarias**

14 **Hermes**

20 **T-1609**

24 **Mix**

28 **Apolo**

34 **Osiris**

38 **Italia**

44 **Juno**

48 **Hera**

52 **Atenea**

56 **Happy**

60 **Litissimo**

Butacas Sièges Seats

64 **Kiss**

64 **Curve**

64 **Wire**



Blezz

La diferencia

La différence

The difference

**Estéticamente
vanguardista
y con mucha
presencia**

Avandgardiste
et ayant
une grande
présence

Avant-garde
aesthetic and
with personality



Blezz

**Líneas rectas,
ángulos
redondeados
y un respaldo
elevado marcan la
diferencia de esta
pieza**

Des lignes droites
des angles arrondis
et un dossier
haut ponctuent la
différence de ce
produit

Straight lines,
curved edges
and a high back
differentiate this
sofa from others





Canarias

**Expresión estética
viva y atemporal**

Une expression esthétique
vive et intemporelle

Timeless and alive
expression of beauty

Ideal para zonas comunes. Muy confortable tanto en sofá como en cama.

Idéal pour les parties communes. Très confortable tant en canapé qu'en version convertible.

Perfect for common areas. Extremely comfortable as sofa and sofa-bed.

Evoca a los clásicos modernos. Es el arquetipo de sofá: un generoso asiento enmarcado por brazos bajos e inclinados y un respaldo mullido muy acogedor. De estética muy actual, se adapta a diversos usos y ambientes.

Une évocation aux classiques "modernes". C'est l'archétype du canapé: une assise généreuse limitée par de bas accoudoirs inclinés et par un dossier moelleux très accueillant. Une esthétique actualisée qui s'adapte à diverses utilisations et ambiances.

It evokes modern classics. The best example of sofas: spacious seat framed with low armrests and a comfortable and welcoming back. A modern look that easily adapts to different areas and purposes.

Canarias





Hermes

Minimalista y funcional

Minimaliste et fonctionnel

Minimalist and functional

La importancia de un volumen atemporal

L'importance d'un volume intemporel

The importance of a timeless volume



Hermes

Una estructura monolítica con respaldo bajo, al mismo nivel que los brazos

Une structure monolithique dont le dossier est à la même hauteur que les accoudoirs

A monolithic structure with low back, the same level as the arms



Orgánico y muy decorativo, con presencia escultórica y vanguardista

Organique et très décoratif, avec une présence sculpturale et d'avant-garde

Organic and very decorative, with sculptural presence





T-1609

**Esencia
y distinción**

Essence
et distinction

Essence
and distinction

**El auténtico
Chéster,
un clásico
irrepetible que
nunca falla**

Authentique
Chester, un
classique
irremplaçable
qui est toujours
à la hauteur

The one and
genuine
Chester, an
irreplaceable
classic
that never
disappoints



T-1609

**Su respaldo bajo
en capitoné y el
tapizado artesanal
con tachuelas y
botones ayudan a
estilizar cualquier
estancia, ahora
también en cama**

Dossier bas
capitoné
rembourré
artisanalement avec
clous et boutons en
font un style pour
toutes les pièces,
existe maintenant
en convertible

With a quilted
low back and
handcrafted
upholstery with
tacks and buttons
that stylized any
room. Now available
as sofa-bed





Mix

**Un nuevo enfoque
de mobiliario
transformable**

Une nouvelle
approche
des convertibles

A new approach
to adaptable
furniture

De línea clara y rigurosa geometría, Mix es un sistema modular activo capaz de múltiples composiciones

Ligne fine et de géométrie rigoureuse, Mix est un système modulaire actif capable de combiner de multiples compositions

Clean lines and strict geometry, Mix is a modular system that allows multiple structures



Mix

Muy funcional y versátil, está enfocado a maximizar cualquier espacio. Diseñado para adaptarse a demanda, cumple función de rinconera, chaise-longue, una o dos camas individuales e incluso una cama doble.

Très fonctionnel et polyvalent, se concentre sur la l'optimisation de tout espace. Conçu pour répondre à la demande, ces fonctions peuvent être angle chaise longue, un ou deux lits simples et même un lit double.

Very functional and versatile, with the purpose of maximizing any room. Designed to meet any requirements, can be used as corner sofa, chaise-longue, single or double bed.





Apolo

**Amable
y sencillo**

Chaleureux
et simple

Nice
and easy

Tiene un volumen creado por figuras geométricas simples y un marcado gesto gráfico

Un volume créé par des figures géométriques simples et un graphisme accentué

Volume created after very simple geometric shapes and a clear graphic design



Apolo

Los botones laterales le confieren un toque elegante y alegre al mismo tiempo. Adaptable tanto a espacios públicos como privados.

Les boutons latéraux lui confèrent tout à la fois une touche élégante et joyeuse. Utilisation en espaces publics ou privés.

The side bottoms provide an elegant and optimistic atmosphere. Adaptable both to public and private areas.



El sofá cama Apolo es también una cama que te ofrece múltiples opciones de sistema de apertura. Se adapta perfectamente a las necesidades de espacio.

Le canapé convertible Apollo offre également de multiples options de systèmes d'ouverture. Il s'adapte parfaitement aux besoins de l'espace.

Apolo is a sofa-bed that as bed can offer several opening systems. Easily adapts to any needs.





Osiris

**Elegancia
en estado puro**

L'élégance à
l'état pur

Pure
elegance

Combinación de líneas rectas que se plasman en una estética muy personal

Combinaison de lignes droites qui se reflètent dans une esthétique très personnalisée

A personal aesthetic look reached through the combination of straight lines



Osiris

Diseño moderno y atractivo que contiene el secreto de la elegancia en estado puro

Design moderne et attrayant, le secret de l'élégance pure

Attractive and modern design that holds the secret of what pure elegance is





Italia

**Funcionalidad
y confort**

Fonctionnalité
et confort

Functionality
and comfort

Geometría racional de formas mínimas, adaptable a cualquier medida de espacio

La géométrie rationnelle des formes minimales, adaptable à tous les espaces

Rational geometry with minimal shapes, adaptable to any space measure



Italia

El reposacabezas articulado adopta diferentes posiciones. Una menor altura genera una decoración más horizontal, diáfana y actual.

Le repose tête articulé adopte différentes positions. En position basse, on retrouve un décor horizontal, transparent et moderne.

The articulated headrest can take different positions. A lower height provides a horizontal decoration, actual and open-plan area.



Elevar el reposacabezas permite apoyar las cervicales para una sentada más cómoda

Relever le repose tête permet de supportet la tête pour une assise plus confortable

Raising the headrest allows the cervical spine a comfortable support





Juno

Vivo y orgánico

Vif et organique

Active and organic

**Vivo, orgánico
y de una gran
personalidad**

Vif, organique
et à grande
personnalité

Active, organic
and with an
outstanding
personality



Juno

**Combina diseño e
innovación con tecnología,
aportando múltiples
soluciones. Entre ellas, el
sofá litera.**

Combine le design
l'innovation avec la
technologique, offrant
de multiples solutions. Y
compris de canapé-lit.

It combines design and
innovation with technology.
It gives multiple solutions,
among them, the bunk bed.





Hera

Pureza y sensualidad

Pureté et sensualité

Purity and sensuality

Ideal para ocupar un rincón especial en el espacio contract, hall, suite o accesos

Idéal en contract pour occuper un endroit particulier hall, des suites ou certains passages

Perfect for contract, halls, suites or doorways

Hera

Sus característicos brazos con una marcada curva aportan un toque de distinción que no pasará desapercibido

Ses accoudoirs caractéristiques aux énormes crosses apportent une touche de distinction qui ne passera pas inaperçu

Its characteristic armrests with a strong curve provide a sense of distinction that will not be overlooked





Atenea

**Firmeza
y elegancia**

Fermeté
et élégance

Firmness
and elegance

**Ideal para
amueblar
interiores de
prestigio, ya
sean públicos
o privados**

**Idéal pour
décorer de
prestigieux
intérieurs,
qu'ils soient
publics ou
privés**

It is perfect
to furnish
important
areas, either
public or
private



Atenea

**Su diseño es elegante y
contemporáneo al mismo
tiempo. Es una cama con un
alto grado de confort.**

Son design est à la fois
élégant et contemporain. La
version lit apporte un haut
degré de confort.

Its design is both elegant and
contemporary. This bed is
truly comfortable.





Happy

**Diseño
e innovación**

Design
et innovation

Design
and innovation

**Sorprendente
y distinguido
sillón cama**

Surprenant
et distingué
fauteuil
convertible

Surprising and
distinguished
armchair-bed



Happy

**Sillón cama mono
plaza muy práctico
y funcional de
diseño y tecnología
innovadora**

Canapé-lit d'une
place très pratique
et fonctionnel,
d'un design et
technologie innovant

Armchair-bed that
turns into a single
bed. Practical and
functional design
and technology





Litissimo

Litissimo





Wire Kiss Curve

Asientos compactos

Assises compactes

Compact seats

Distinguidas y de gran personalidad se adaptan con facilidad al hogar, la oficina o al restaurante

Distingué et à grande personnalité, s'adapte facilement à la maison, au bureau ou au restaurant

Elegant and with a remarked personality that easily adapt to home, office or restaurant

Wire



Curve



Kiss

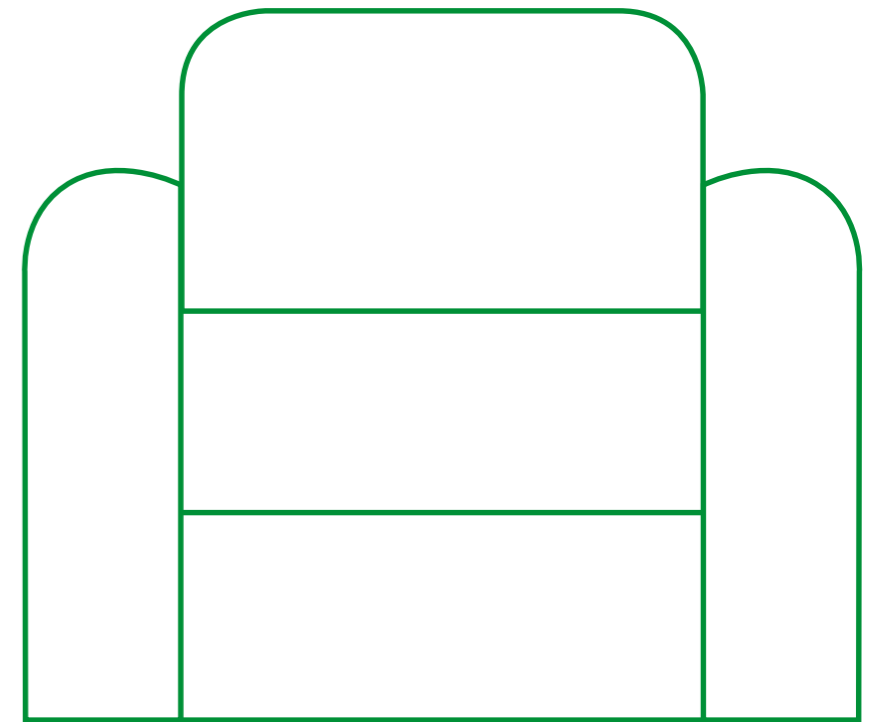
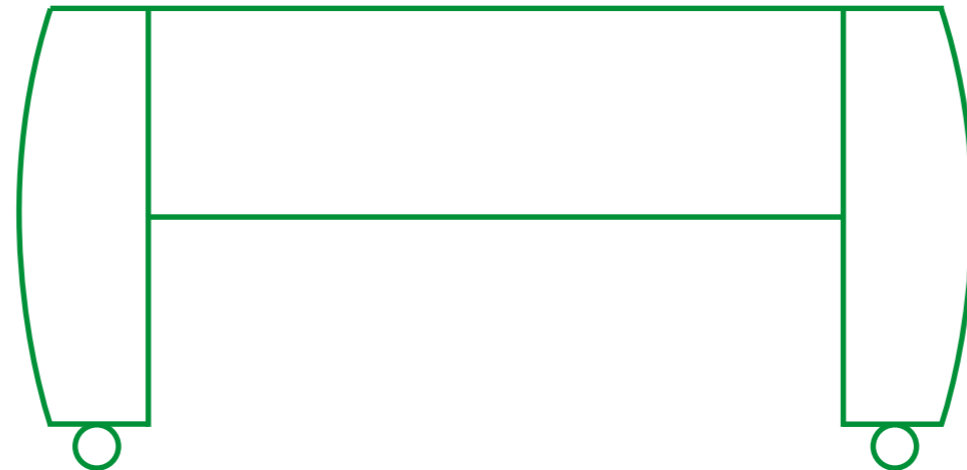
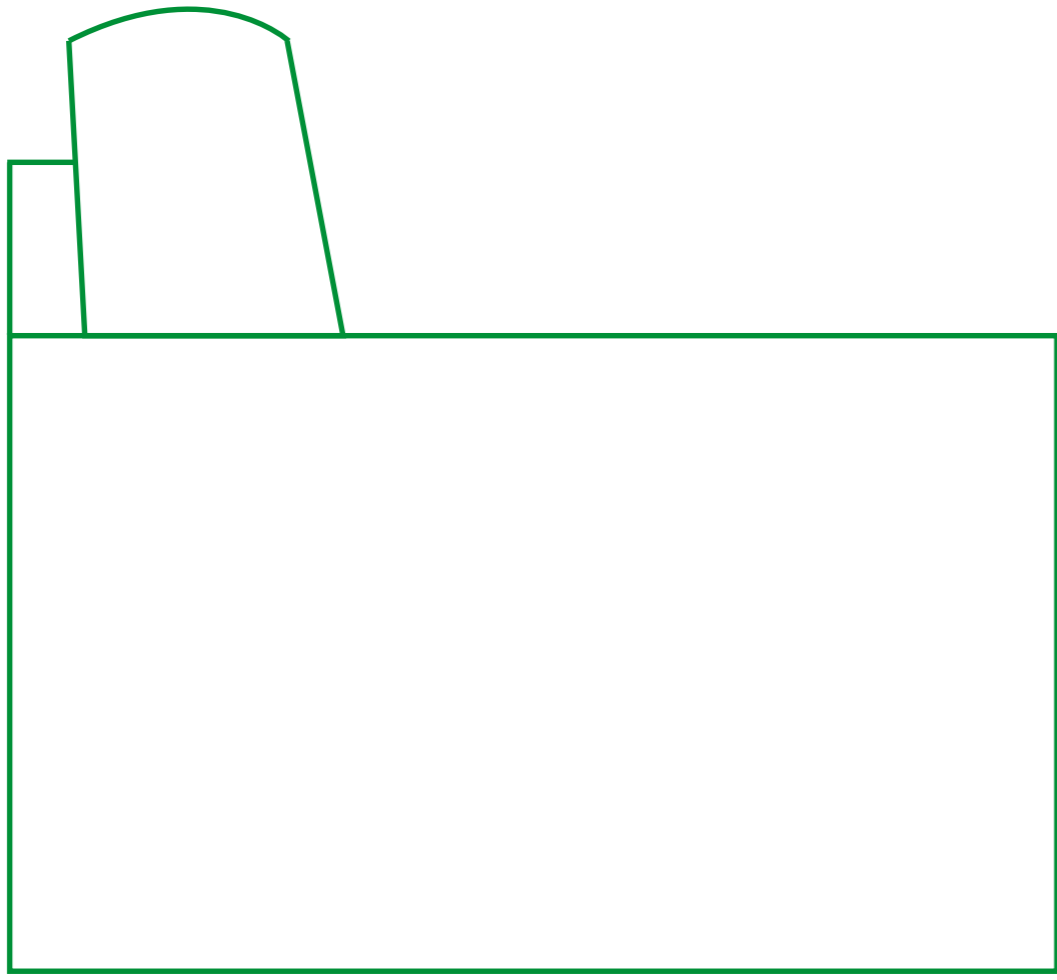
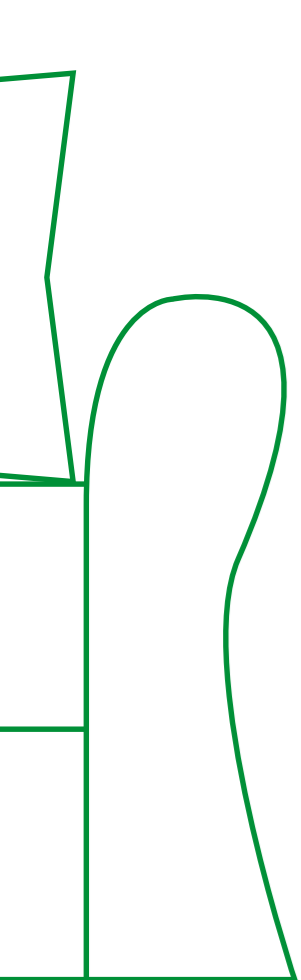
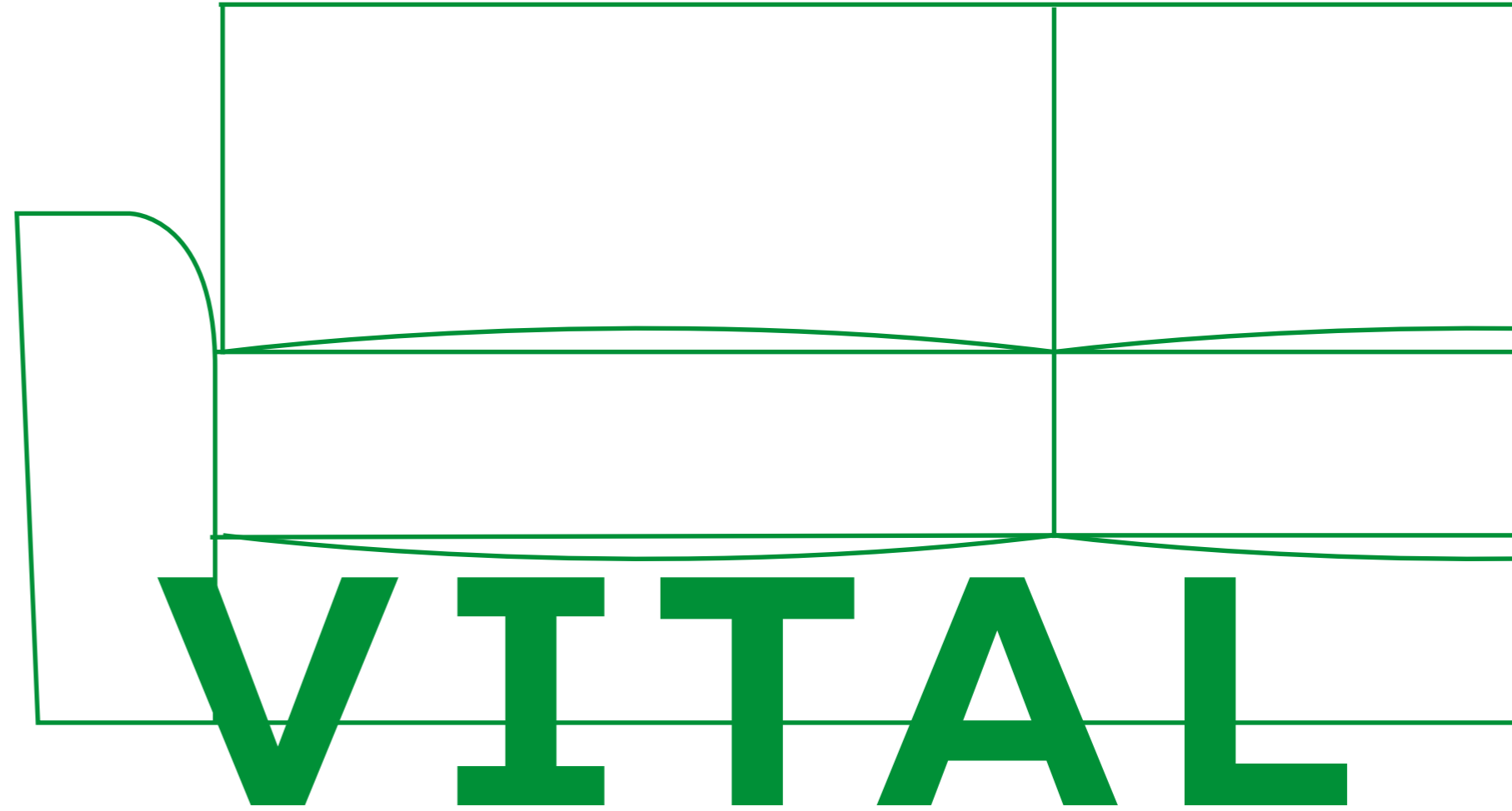
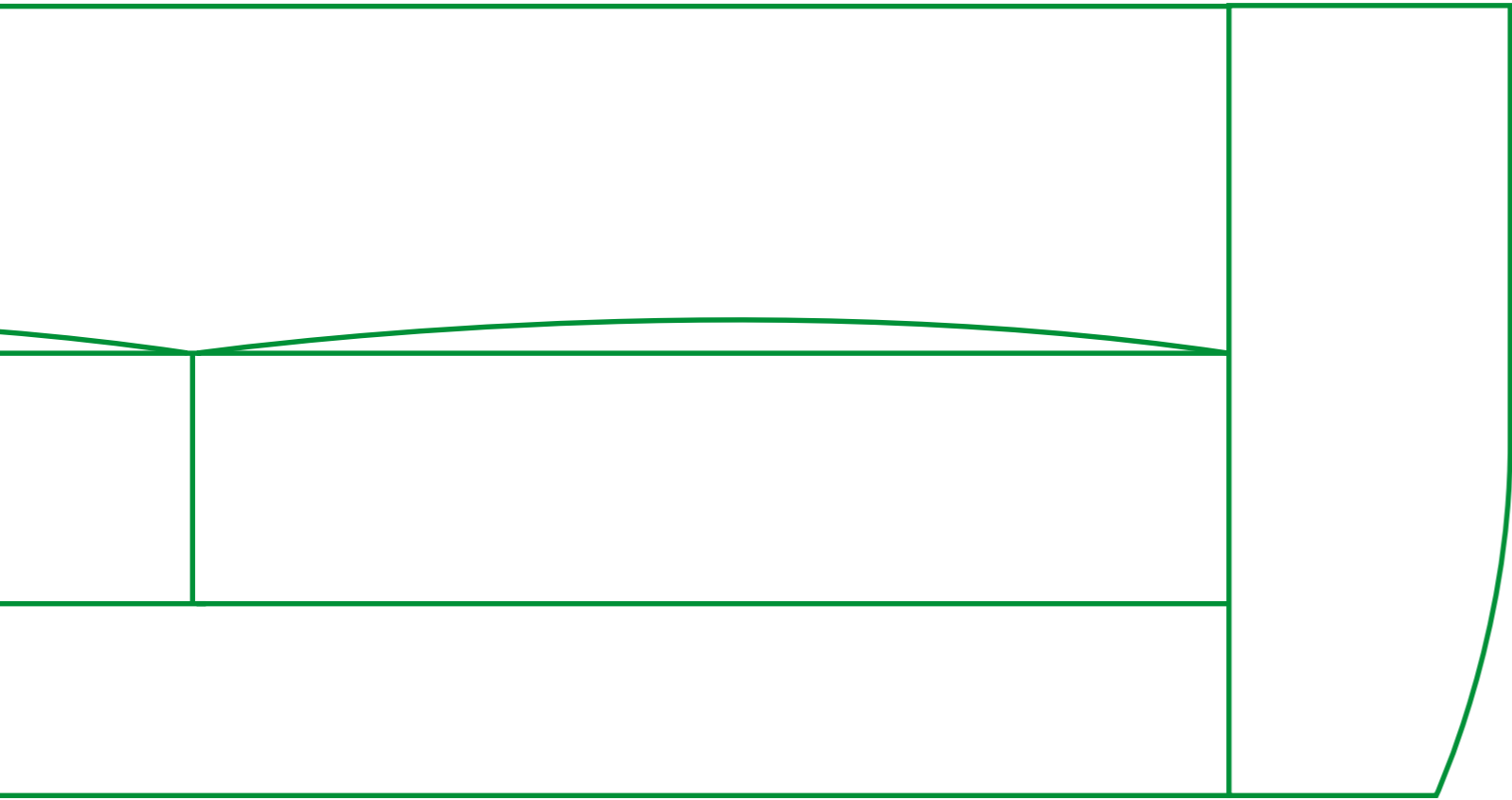

Blezz



**Fijo
3pl**

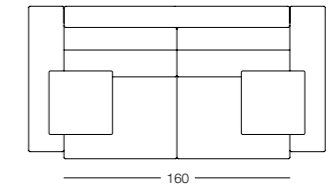
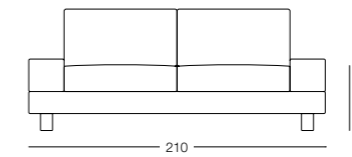
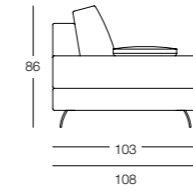

**Fijo
2pl**

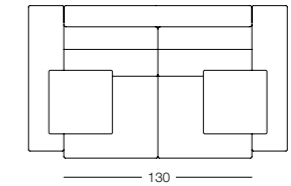
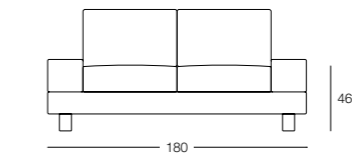
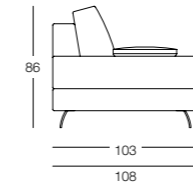

**Cama 3pl
italiana**

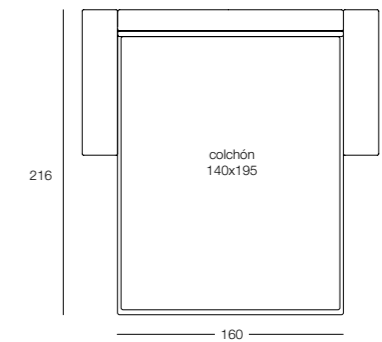
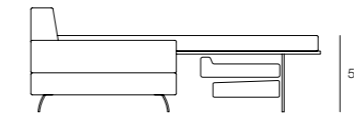
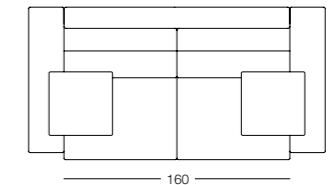
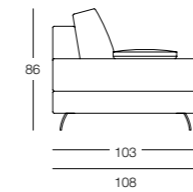

Canarias



Sofa 233

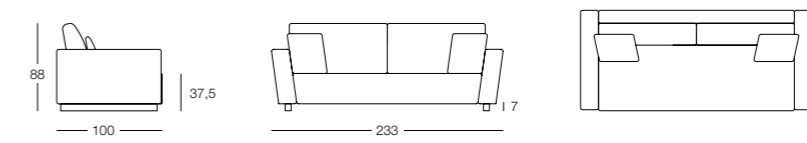

Sofa 203

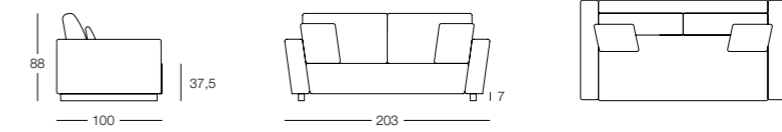

Sofa 173

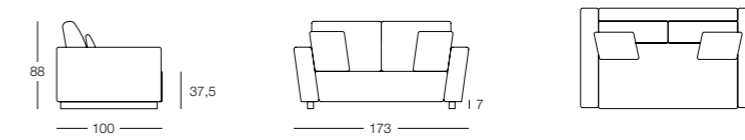

Sillón 114

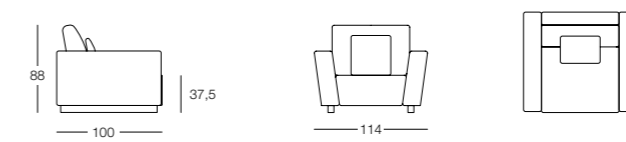

Sofa cama 140

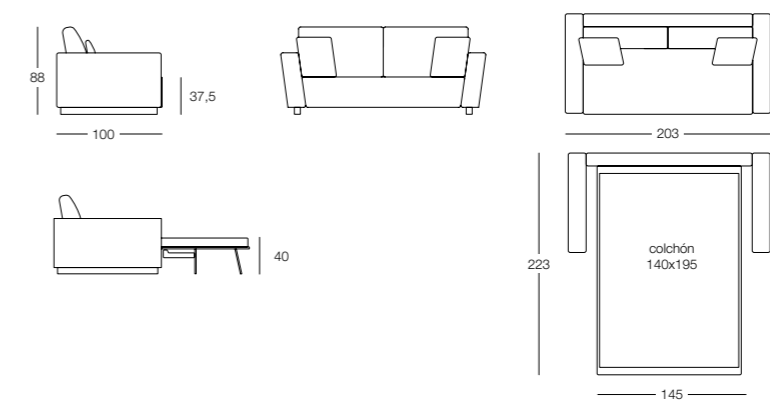

Sofa cama 160

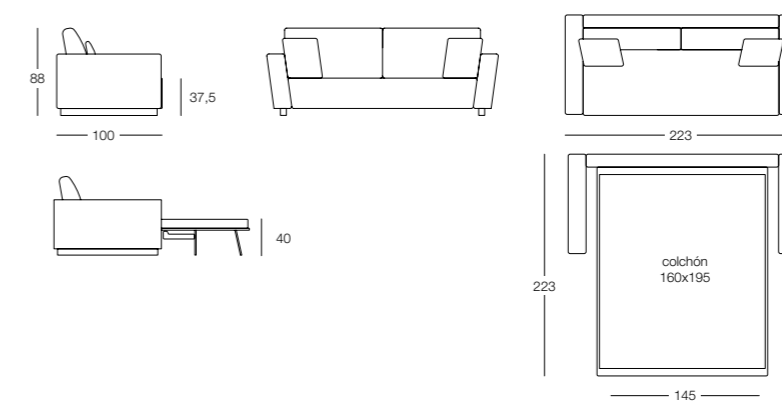

Hermes



**Hermes 3,5 pl.
Mechless**

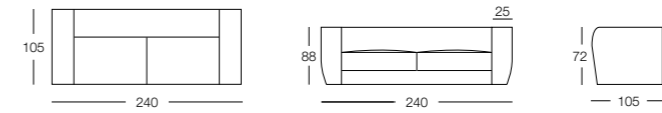

**Hermes 3 pl.
Mechless**

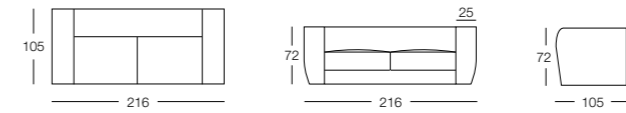

**Hermes 1 pl.
Mechless**

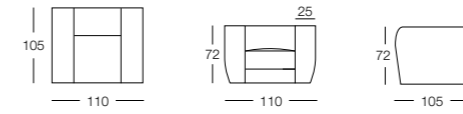

**Hermes 3 pl.
Italiano**

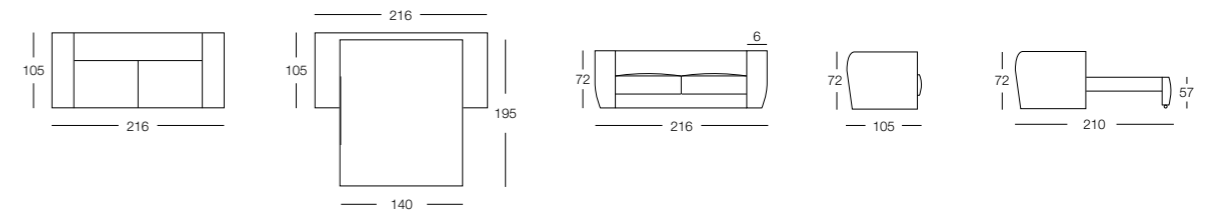

**Hermes 1 pl.
Italiano**

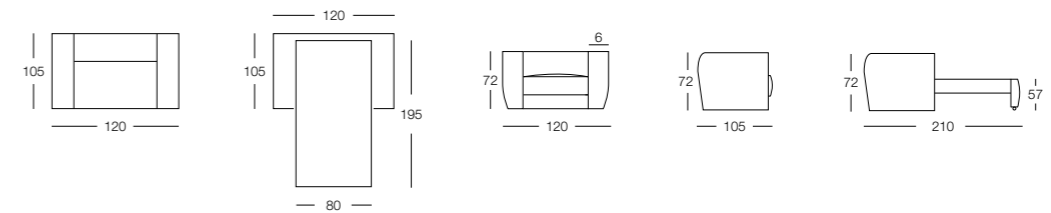

**Hermes 3,5 pl.
Nido**

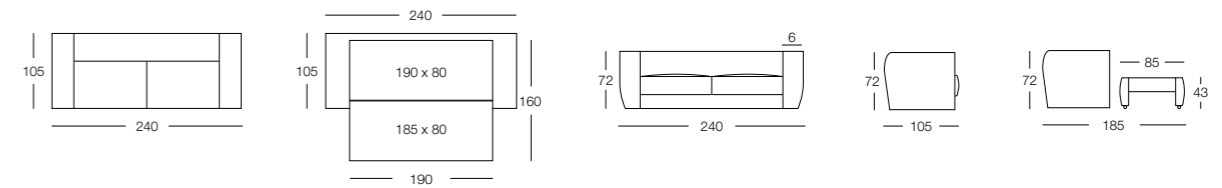

**Hermes 3,5 pl.
Mercurio**

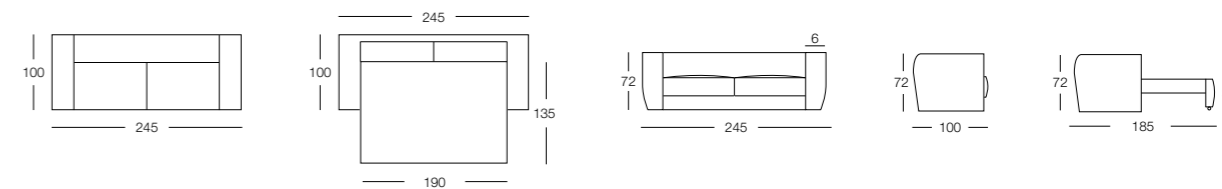

T-1609



**Fijo
3pl**

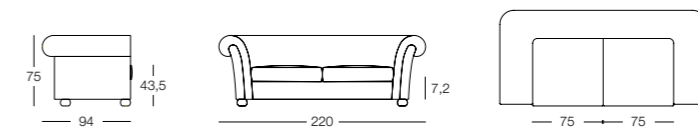

**Fijo
2pl**

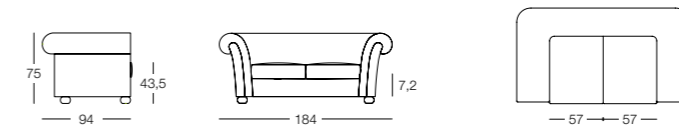

Sillón

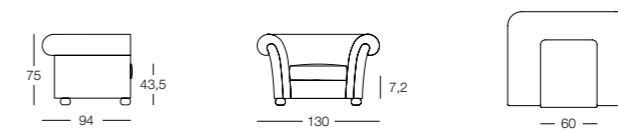

**Cama
160**

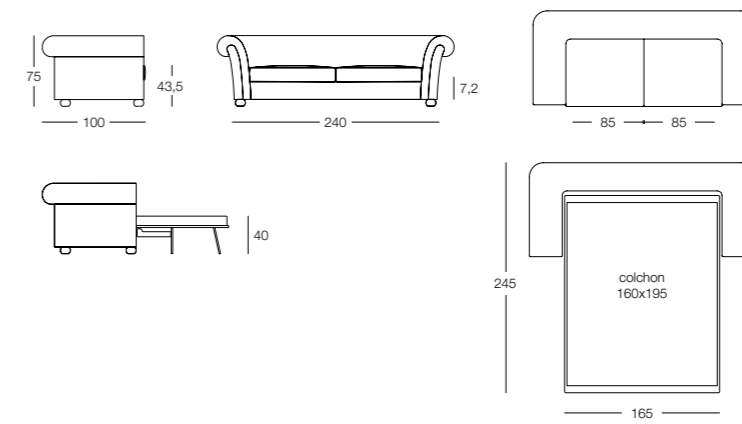

**Cama
140**

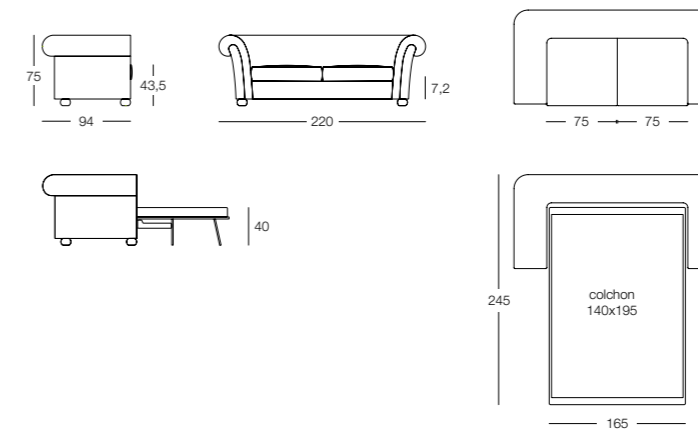

Mix



Rinconera con chaise longue

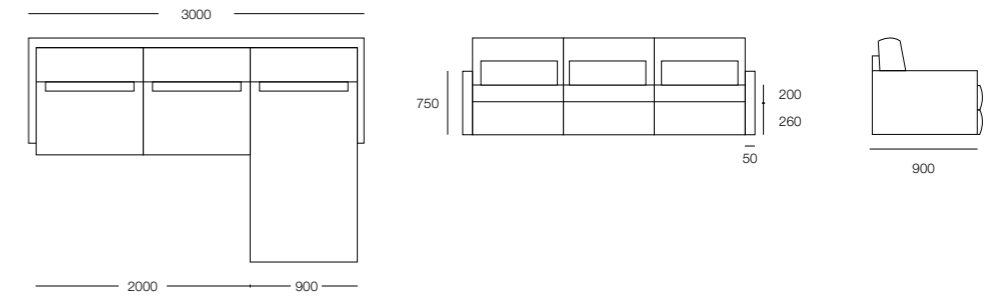

Cama doble

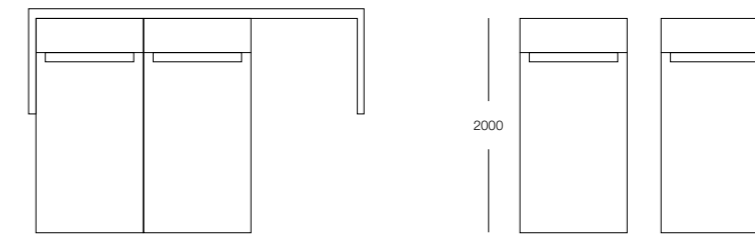

Almohada y cojín



Apolo



**Apolo 3,5 pl.
Mechless**

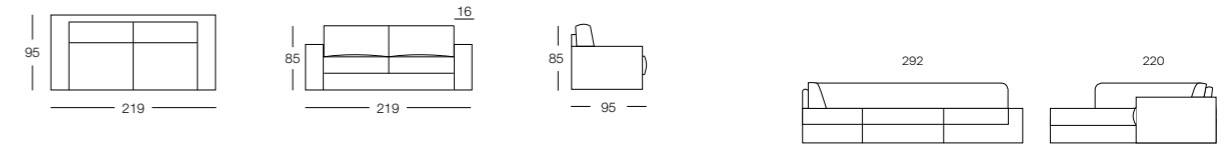

**Apolo 3 pl.
Mechless**

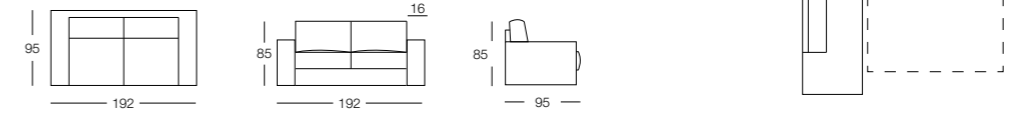

**Apolo 1 pl.
Mechless**

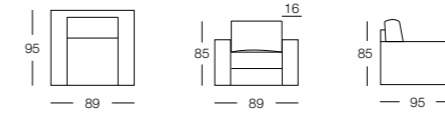

**Apolo 3,5 pl.
Italiano**

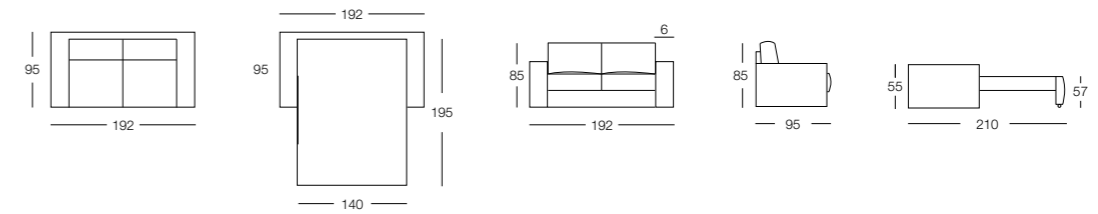

**Apolo 1 pl.
Italiano**

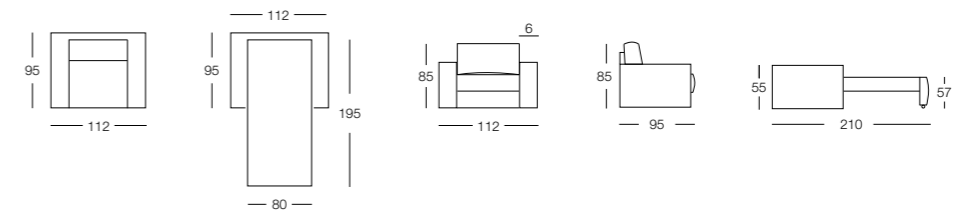

**Apolo 3,5 pl.
Nido**

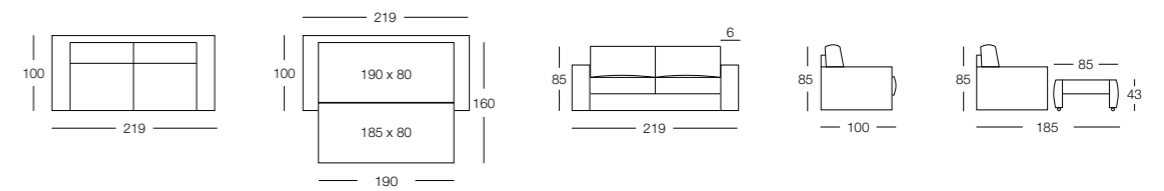

**Apolo 3,5 pl.
Olimpo**

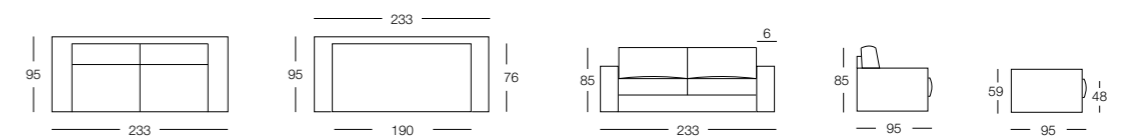

Osiris



**Osiris 3,5 pl.
Mechless**

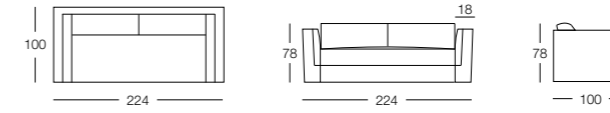

**Osiris 3 pl.
Mechless**

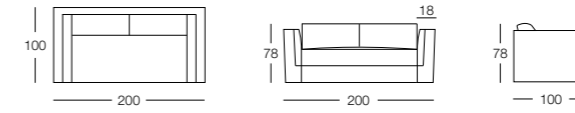

**Osiris 1 pl.
Mechless**

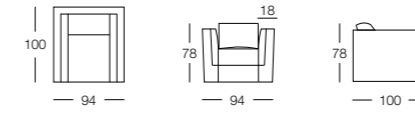

**Osiris 3,5 pl.
Italiano**

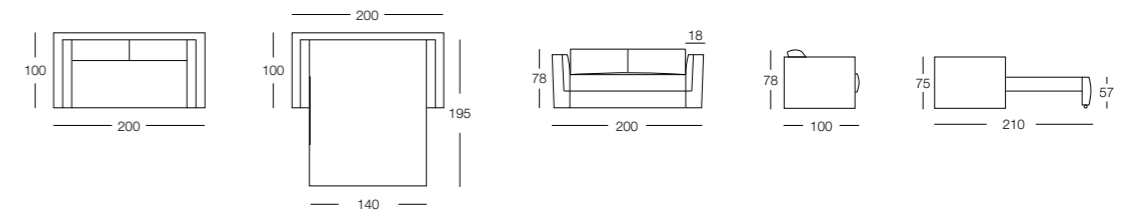

**Osiris 1 pl.
Italiano**

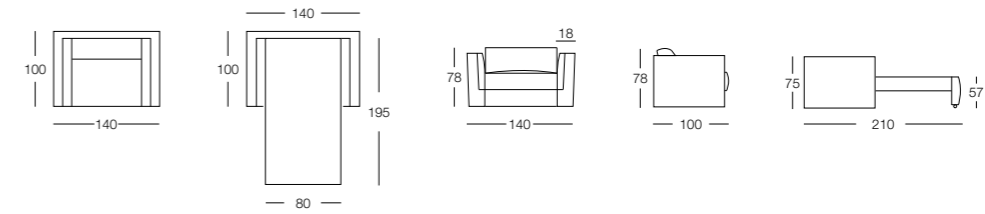

**Osiris 3,5 pl.
Nido**

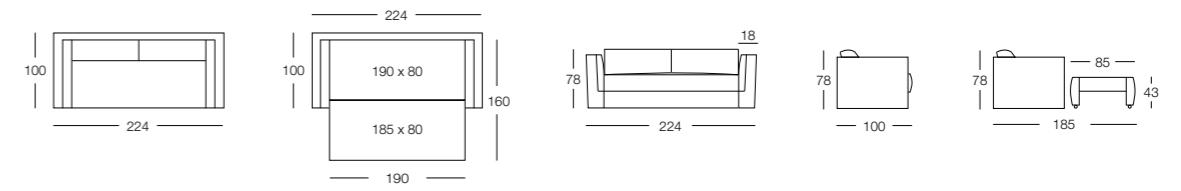

**Osiris 3,5 pl.
Mercurio**

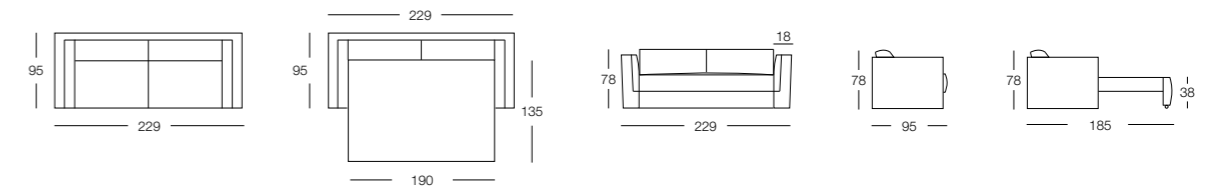

**Osiris 3,5 pl.
Olimpo**

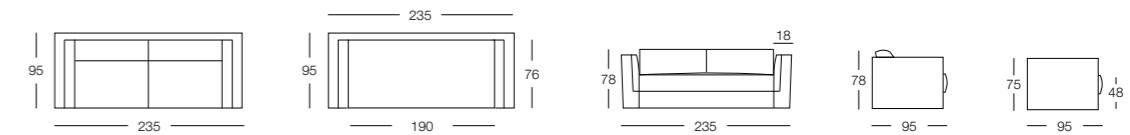

**Osiris 3,5 pl.
Venus**

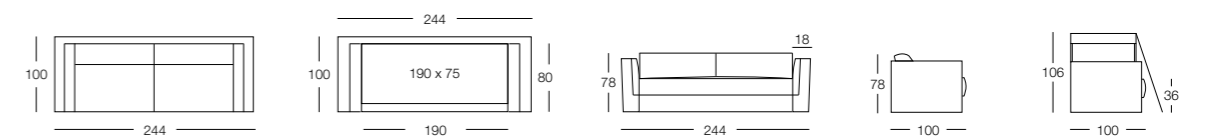

Italia



Sofa PL 198

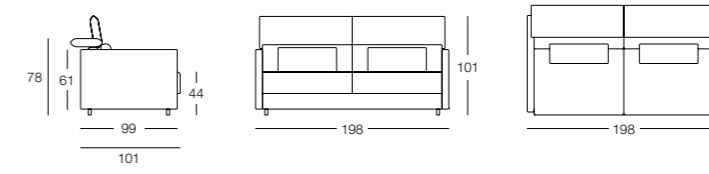

Fijo 2pl 178

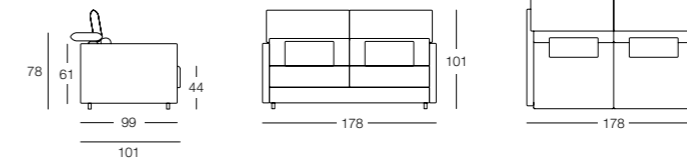

Sillon 85

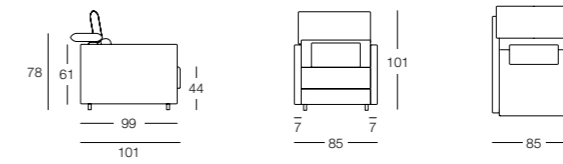

Sofa 3pl cama 198

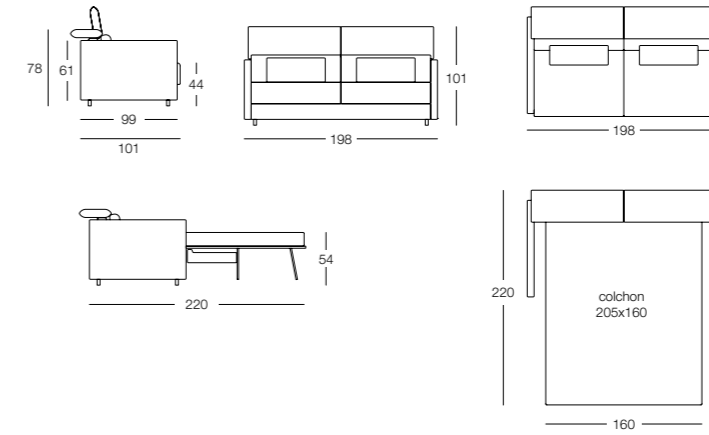

Sofa 2pl cama 178

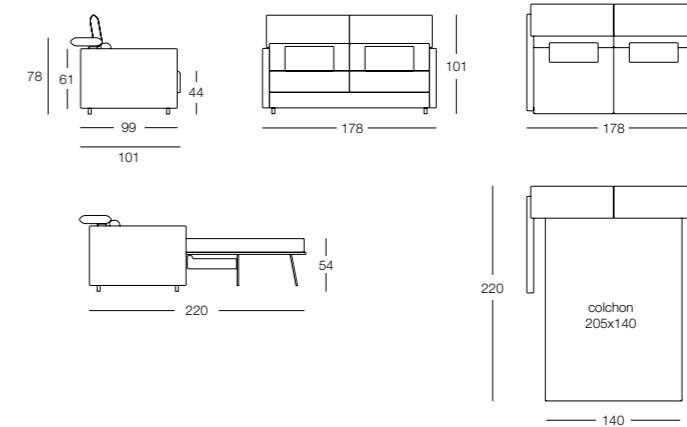

**Cojin 3pl
Cojin 2pl y sillon**

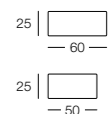

Juno



**Juno 3,5 pl.
Mechless**

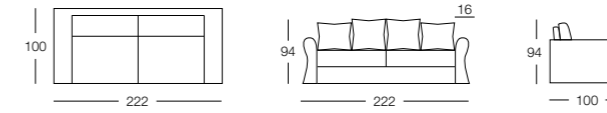

**Juno 3 pl.
Mechless**

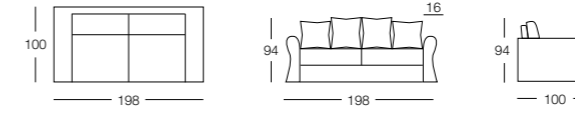

**Juno 1 pl.
Mechless**

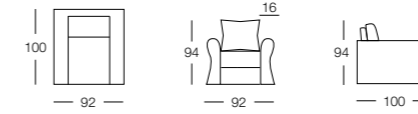

**Juno 3,5 pl.
Italiano**

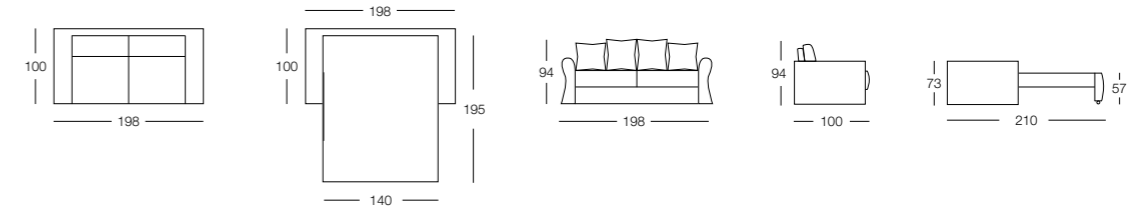

**Juno 1 pl.
Italiano**

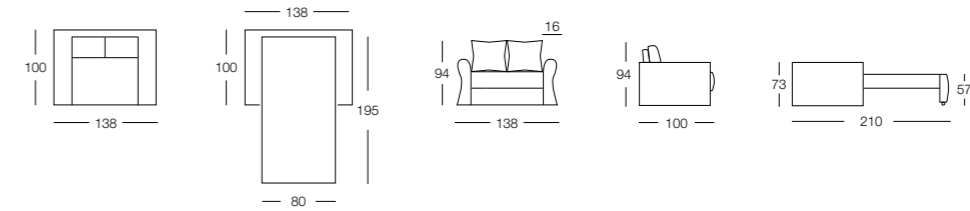

**Juno 3,5 pl.
Nido**

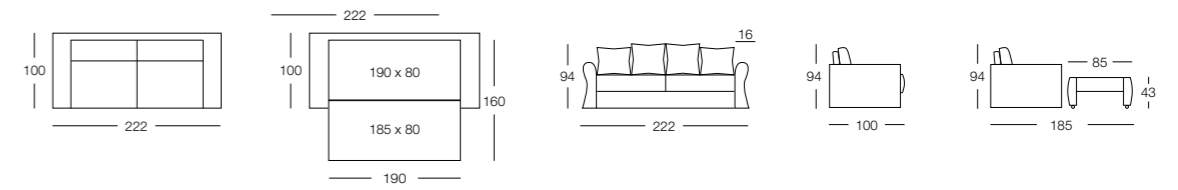

**Juno Chaise Longue
Nido**

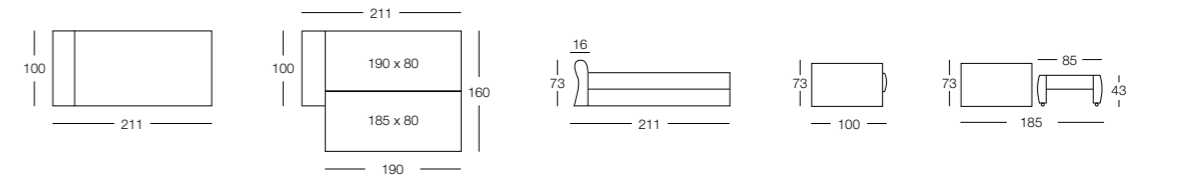

**Juno 3,5 pl.
Mercurio**

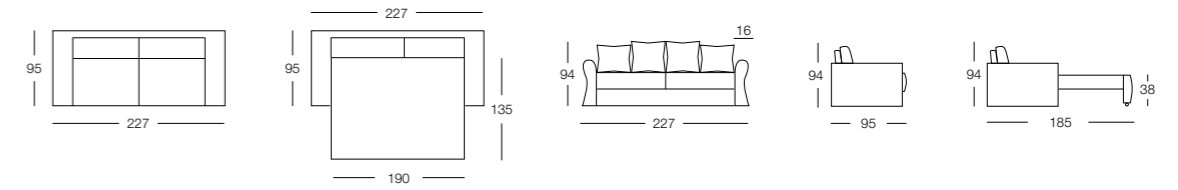

**Juno 3,5 pl.
Olimpo**

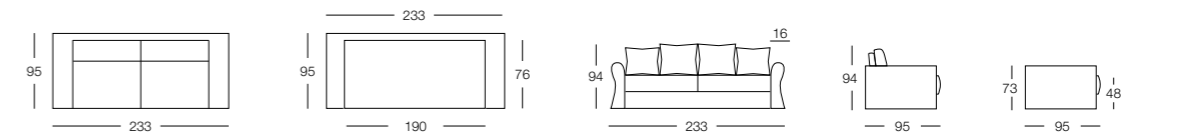

**Juno 3,5 pl.
Venus**

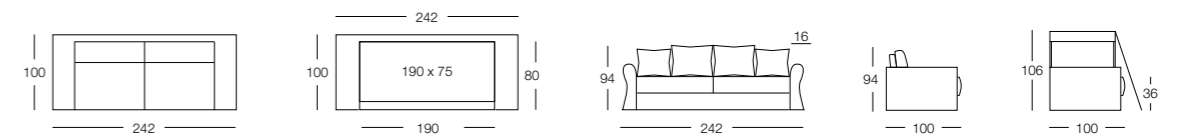

Hera



**Hera 3,5 pl.
Mechless**

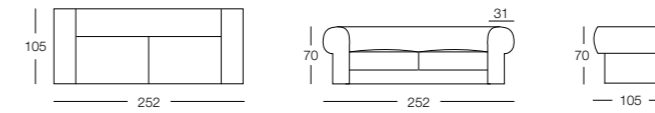

**Hera 3 pl.
Mechless**



**Hera 1 pl.
Mechless**

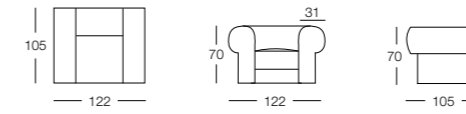

**Hera 3 pl.
Italiano**

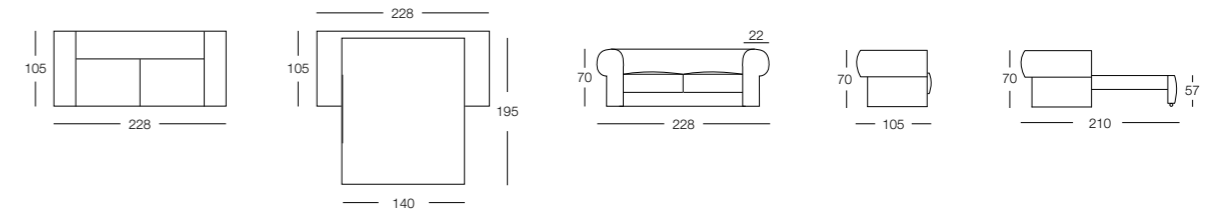

**Hera 1 pl.
Italiano**

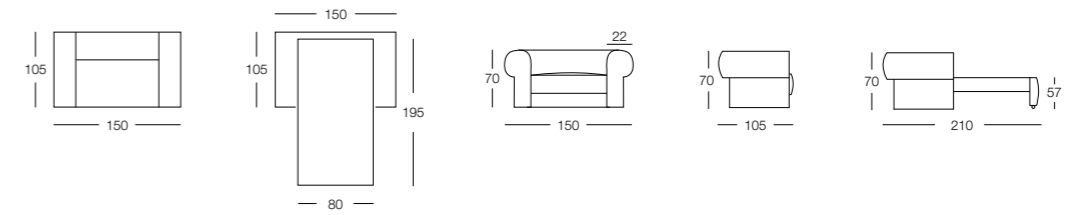

**Hera 3,5 pl.
Nido**

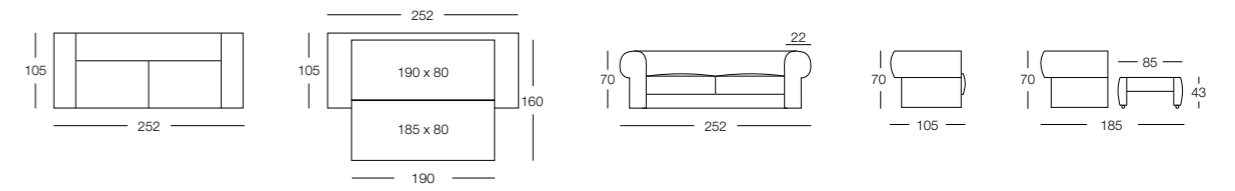

**Hera 3,5 pl.
Mercurio**

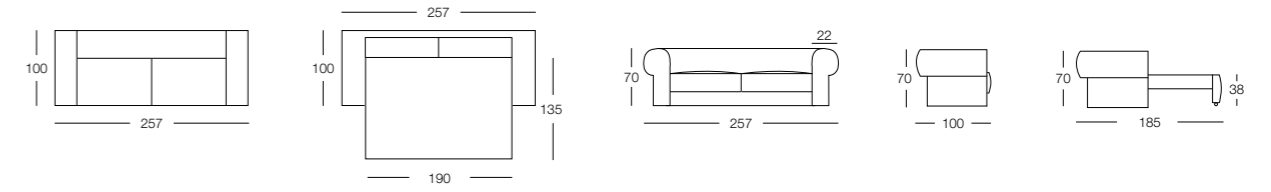

Atenea



Atenea 3,5 pl.
Mechless

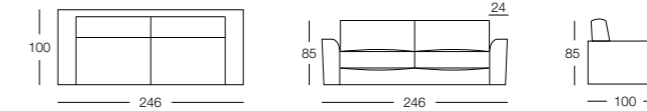

Atenea 3 pl.
Mechless

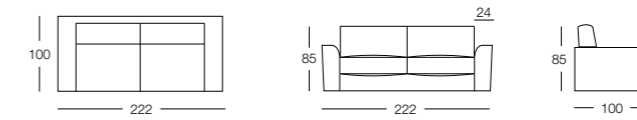

Atenea 1 pl.
Mechless

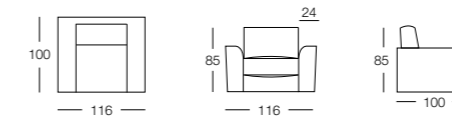

Atenea 3,5 pl.
Italiano

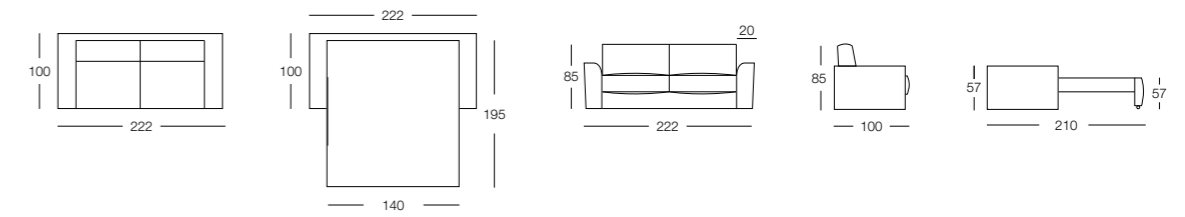

Atenea 1 pl.
Italiano

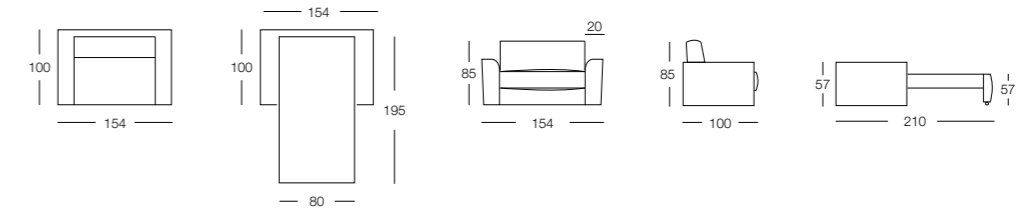

Atenea 3,5 pl.
Nido

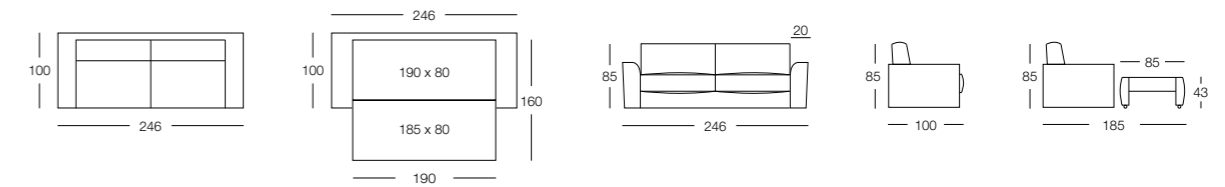

Atenea 3,5 pl.
Mercurio

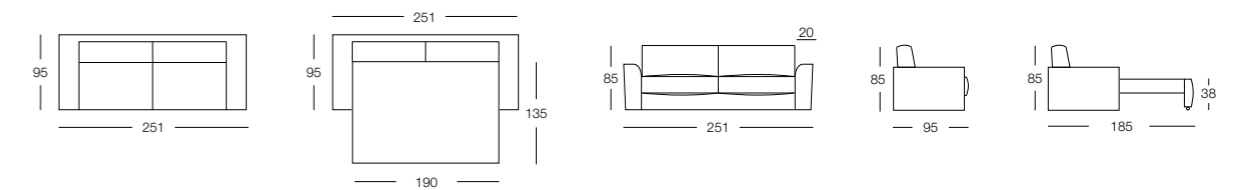

Atenea 3,5 pl.
Olimpo

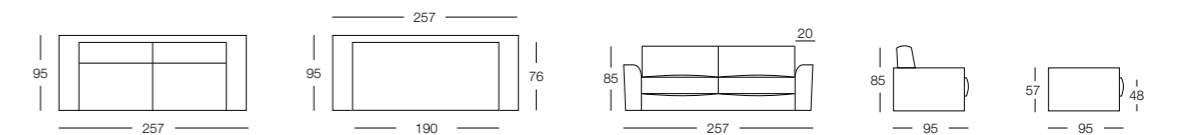

Atenea 3,5 pl.
Venus

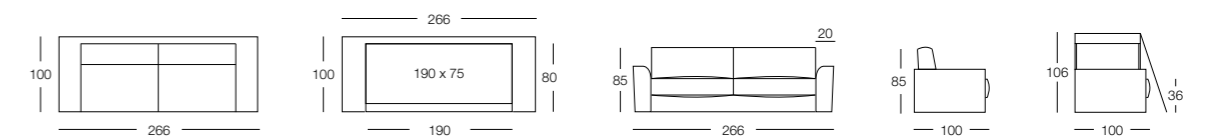

Happy



Sillón Fijo

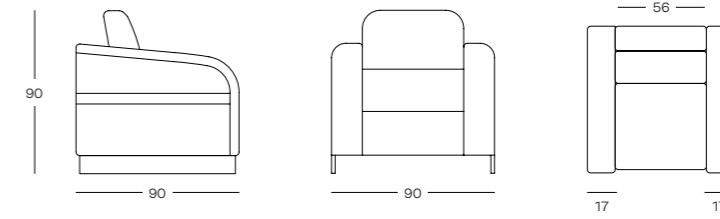

Sillón cama

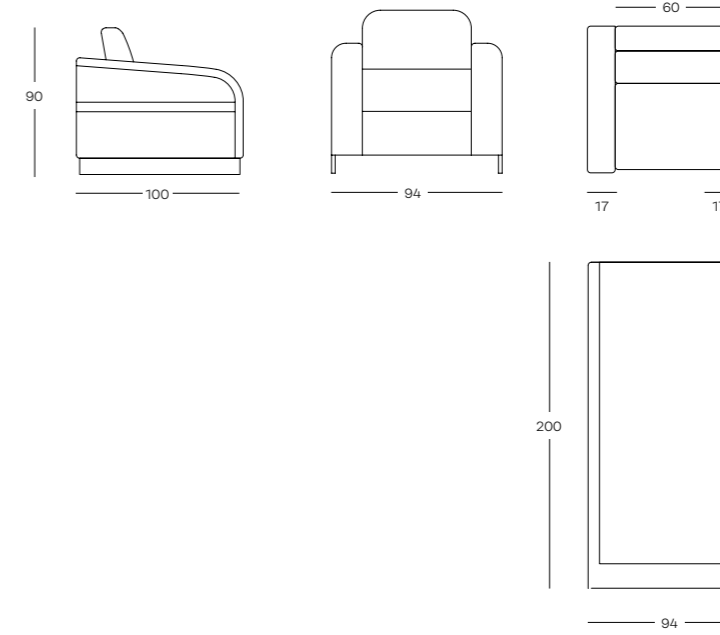

Litissimo



**Sillón cama
140x200**

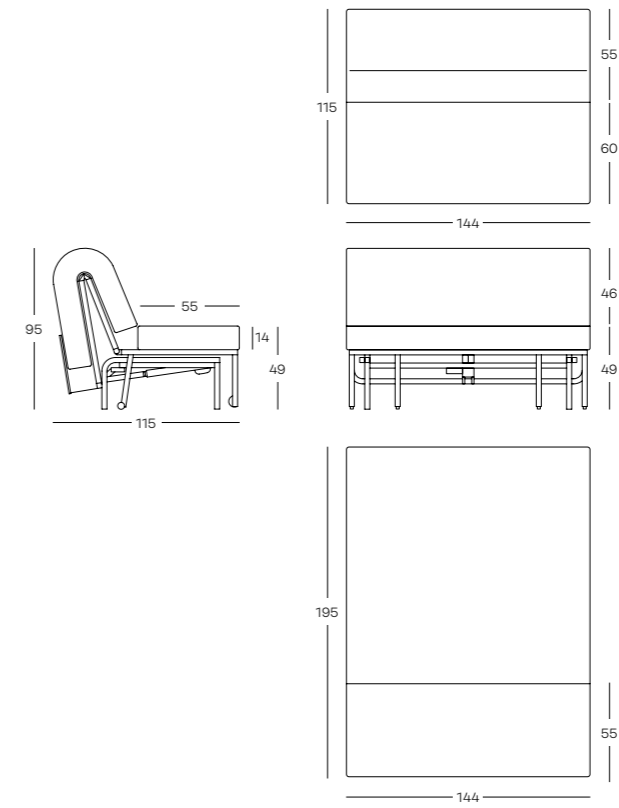

**Sillón cama
160x200**

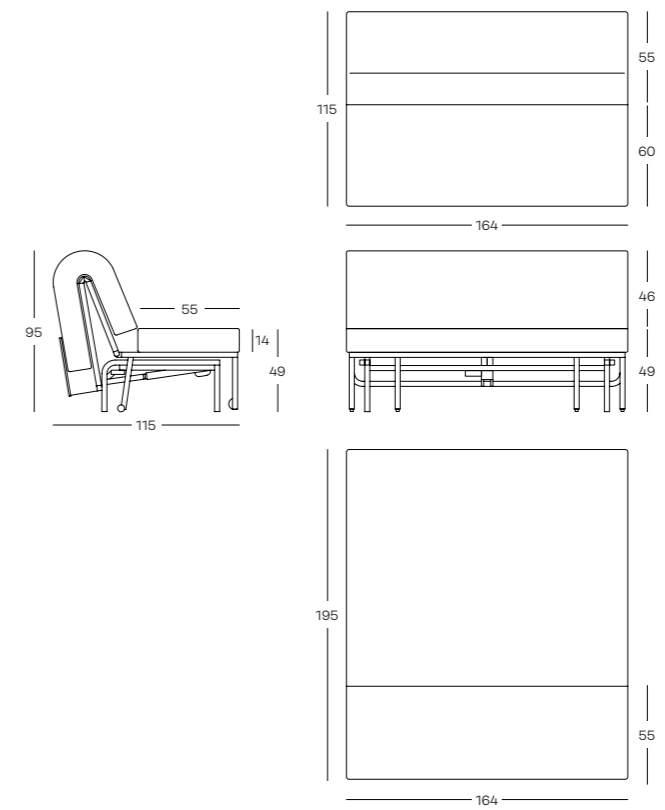

Curve Kiss Wire



Curve

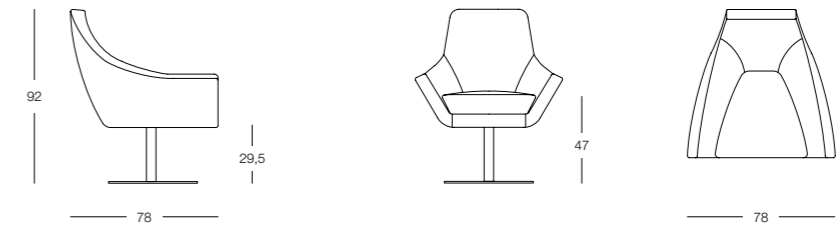

Kiss

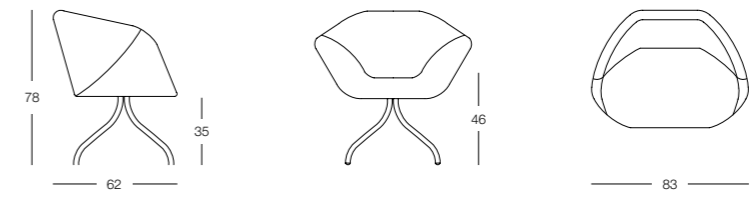

Wire

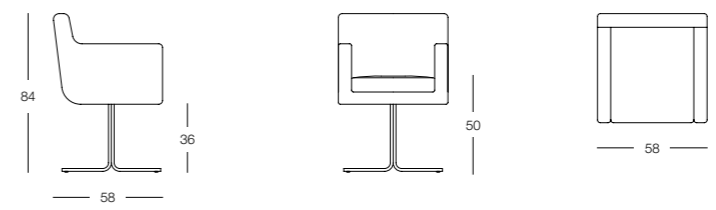

Calidades técnicas colchones
Mecanismos cama disponibles
Mattress technical qualities

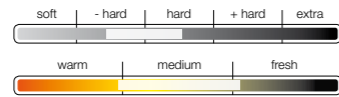

**SISTEMA ITALIANO
DIANA**

- Grosor 10-11 cm.
- Núcleo 30 kg/m³ suave.
- Épaisseur 10-11 cm
- Noyau 30 kg/m³ doux.
- Thickness 10-11 cm.
- Core 30 kg/m³ soft foam.

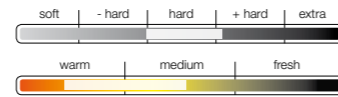

**SISTEMA ITALIANO
MINERVA**

- Grosor 10-11 cm.
- Núcleo 35 kg/m³ alta resiliencia (HR) + 10 mm de viscoelástica en acolchado.
- Épaisseur 10-11 cm.
- Noyau 35 kg/m³ haute résistance (HR) + 10 mm de viscoélastique dans le rembourrage.
- Thickness 10-11 cm.
- Core 35 kg/m³ high resilience (HR) + 10 mm de viscoelastic in padding.

Relación de combinaciones
Relación de combinaciones
Combinations available

Modelo	Italiano		Olimpo	Milan-T	Venus	Nido	Opla	Canapé Abatible	Bz Motor
	Attaflex	Sterna							
Atenea		✓	✓	✓					
Osiris	✓		✓	✓	✓				
Apolo	✓		✓	✓		✓			
Hera	✓				✓				
Hermes	✓				✓				
Juno	✓				✓	✓			
Blezz		✓							
Happy							✓		
Mix								✓	
Canarias		✓							
T-1609		✓							
Italia	✓								

Italiano Attaflex



Italiano Sterna



Milan-T

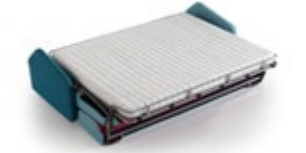

Venus



Nido



Opla



Canapé Abatible



1975

Pedro Rubio funda Ecus, inicialmente dedicada a la transformación de espumas de poliuretano.

Pedro Rubio fonde la société Ecus, initialement dédié à la transformation de mousse de polyuréthane.

Pedro Rubio established Ecus, initially focused on polyurethane foam transformation.



1979

Traslado a la actual localización, 5.000 m²

Installation à notre emplacement actuel, 5.000 m²

Relocation to its actual location, 5.000m²

1984

Fabricación de los primeros colchones de muelle biconico. Adquisición de la primera máquina automática de muelles Sphüll.

Fabrication des premiers matelas à ressorts biconiques. Acquisition de la première machine automatique à ressorts Sphüll.

Bi-conical spring mattresses are first produced. A Sphüll machine is acquired (automatic spring machine).

1992

Ampliación de las instalaciones, 7.500 m². Capacidad de producción 500 uds./día.

Agrandissement de nos installations, 7.500 m². Capacité de production 500 unités/jour.

Industrial plant increased, 7.500m². 500 units a day can be produced.

1998

Inauguración de nueva ampliación, 13.000 m². Capacidad producción 1.000 uds./día.

Inauguration de la nouvelle extension, 13.000 m² la capacité de production 1.000 unités./jour.

New plant increasing: 13.000m². 1.000 units a day can be produced.



1999

Certificado de Calidad ISO 9001

Certification de qualité ISO 9001

ISO 9001 Quality Standard

2000

Creación del departamento interno I+D+i.

Création du Département R & D.

R+D+i department created.

2001

Adquisición de maquinaria de muelle ensacado. Creación de la marca Multispring®. Facturación 6 millones €.

Acquisition de machines pour la fabrication de ressorts ensachés. Création de la marque Multispring®. CA 6 M€.

Pocket spring machinery acquired. Multispring® brand is created. 6 million € invoiced.



2003

Premio Joven Emprendedor de Andalucía.

Prix aux jeunes entrepreneurs Andalousie.

Young Entrepreneur Award (Given by the Andalusian government).



2004

Certificado de Medio Ambiente ISO 14001. Facturación 15 millones €.

Certificat Environnemental ISO 14001. CA 15 M€.

ISO 14001 Certified Environmental Quality. 15 million € invoiced.



2006

Lanzamiento línea contract. Primeras campañas en TV: La1, T5, 4 ¿Y tú con que sueñas?

Lancement de la ligne Contract. Premières campagnes à la télévision: sur la 1, T5, 4 Et vous à quoi rêvez-vous?

Contract range is launched. First TV campaign: La1, T5, 4. What do you dream about?

2007

Facturación 23 millones €. CA 23 M€ 23 million € invoiced.

2008

Internacionalización. Tiendas en China.

Internalisation. Overture de magasins en Chine.

Internationalization. Shops in China.

Kids

2009

N&G Premio a la Excelencia como empresa proveedora. Nueva línea de negocio Ecus Kids.

N & G Prix a l'excellence comme fournisseur. Nouvelle ligne de négoce: Kids Ecus.

N&G Excellence Award as supplier company. Ecus Kids new business range.

2010

Implantación de planta productiva en São Paulo, Brasil, desde la que suministra productos a Brasil y Bolivia.

Mise en marche de l'unité de production de São Paulo, Brésil, à partir de laquelle nous fournissons des produits au Brésil et la Bolivie.

New manufacturing facilities in Sao Paulo (Brazil) from where products are delivered to Brazil and Bolivia.

Premio Innovación en Diseño, IV Edición Premios de Innovación Empresarial Región de Murcia.

Prix à l'innovation en design, quatrième édition Prix d'innovation entrepreneuriale Région de Murcie.

Innovation and Design Award, IV Edition Business Innovation Awards County of Murcia.

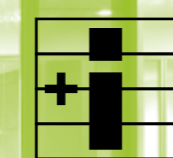

AU LIT

2012

Lanzamiento línea sofás. Nueva gama Au Lit.

Lancement de la ligne de canapés. Nouvelle gamme Au Lit.

Sofa range lauched. Au Lit new range.

2013

Apertura en mercado francés. Red propia. Apertura EAU y Sudáfrica.

Ouverture du marché Français, ainsi que les marchés Emirats Arabes Unis et l'Afrique du Sud.

French market opening. Internal network. Launch in UAE and South Africa.

2015

Presentación de Ecus Care. Apertura en Arabia Saudí.

Présentation de Ecus Care. Ouverture du marché en Arabie Saoudite.

Ecus Care is introduced. Saudi Arabia launching.

care

2016

50% de ingresos en exportación. 150 empleados. Ampliación instalaciones 15.000 m²

50% du CA à l'exportation. 150 employés. Agrandissement des installations 15.000 m²

50% export income. 150 employees. Industrial plant increased to 15.000 m²

Fabricamos mobiliario para facilitar el equipamiento de sus espacios
 Nous fabriquons du mobilier pour faciliter l'agencement de vos espaces
 We manufacture furniture to provide equipment for your contract space



Ecus

Algunos de nuestros catálogos especializados

Quelques uns de nos catalogues spécialisés

Some of our specialized catalogues



Trabajamos en estrecha relación con agencias e ingenieros de producto, gabinetes de arquitectura, estudios de diseño de interiores... lo que nos permite ser aliados del creador proyectista. Colaborar con profesionales especializados nos ha conducido a la edición de catálogos claramente diferenciados.

Notre travail en étroite collaboration avec les ingénieurs ou études d'ingénierie « produit », architectes, architectes d'intérieur, designer, décorateurs ..., nous permet d'être les alliés du créateur des projets. La collaboration avec les professionnels spécialisés nous a conduits à l'élaboration de produits clairement différenciant.

We closely work with agencies and product engineers, architectural firms, interior design studios... which allows us to be allies of the designer creator. Collaborating with specialized professionals has led us to have clearly different catalogues.

Poder comprender la función específica de un mobiliario a menudo requiere una explicación rigurosa. No dudes en solicitarnos el catálogo o publicación que te interese, está diseñada especialmente para ti.

Pouvoir comprendre chaque besoin et fonction spécifique nécessite des explications précises et rigoureuses. N'hésitez pas à nous demander l'envoi du catalogue ou documentation qui vous intéresse, Ils ont été conçus pour vous.

To understand the specific function of a piece of furniture usually requires a thorough explanation. Do not hesitate to ask for a catalogue or publication of your interest, they have been specially designed for you.

Sigue la innovación del contract
 Suivez l'innovation du contract
 Keep up with contract innovation

www.ecussleep.com
hablamos@ecus.es

(+34) 968 751 374
(+34) 902 306 040

ecus

Debido a los límites de las tecnologías visuales y de impresión, los colores representados y/o impresos pueden variar ligeramente de la realidad. Límite de responsabilidad: la exactitud de la información contenida en este catálogo se comprobó antes de la impresión. Los productos o cualidades de los mismos podrían variar después de la publicación por circunstancias que escapan al control de Ecus. Excepto mención contraria, Ecus es propietaria de los derechos de copyright asociados a esta publicación. Ninguna parte de esta revista puede publicarse, distribuirse, extraerse, reutilizarse o reproducirse bajo ninguna forma material (incluso fotocopia o almacenamiento en soporte electrónico) según lo establecido en las disposiciones legales relativas a la propiedad intelectual. • Diseño de producto: Departamento I+D+i e Ingeniería Ecus. Fotografía producto: David Segura, El Molino y Photo Integra. Dirección de arte y diseño de catálogo: Estándar www.estandar.info.

En raison des limites des technologies visuelles et d'impression, les couleurs représentées et / ou imprimées peuvent légèrement varier de la réalité. Responsabilité limitée : la précision des informations contenues dans ce catalogue a été vérifiée avant l'impression. Les produits ou leurs caractéristiques peuvent varier après publication pour des raisons indépendantes de la société Ecus. Sauf indication contraire, Ecus détient les droits d'auteur associés à cette publication. Aucune partie de ce catalogue ne peut être publiée, distribuée, réutilisée ou reproduite sous aucun support matériel (y compris photocopie ou stockage sur support électronique) comme établi par les lois relatives à la propriété intellectuelle. • Conception produit : Département R & D Ingénierie Ecus. Photographie produit : David Segura, El Molino et Photo Integra. Direction artistique et catalogue : Estándar www.estandar.info

Due to the limits of visual and printing technologies, the presented and/or printed colours may vary slightly from reality. Limitation of liability: The accuracy of the information contained in this catalogue was verified before being printed. The products or qualities of the products may vary after the publication of this catalogue due to circumstances beyond Ecus' control. Except where otherwise stated, Ecus is the owner of the Copyrights associated to this publication. No part of this magazine may be published, distributed, removed, reused or reproduced in any material form (not even photocopied or stored on an electronic device) according to the legal provisions regarding intellectual property. • Product design: R&D+I Department and engineering Ecus. Product photography: David Segura, El Molino and Photo Integra. Art and catalogue director: Estándar www.estandar.info

Ref. 15006-Ecus-Sofas-2016-Vital
 Ed. 1a 17 octubre 2016
 © Ecus Sleep S.L.U.



