

POINT.

CONTRACT BOOK

2022 2023

ÍNDICE

INDEX

DESIGNERS	4	DISEÑADORES
CHAIRS	8	SILLAS
ARMCHAIRS	14	SILLONES COMEDOR
CLUB SMALL LOUNGE CHAIRS	24	SILLONES CLUB
DINING TABLES	40	MESAS COMEDOR
COFFEE TABLES	54	MESAS CENTRO
SIDE TABLES	74	MESAS AUXILIARES
HIGH TABLES	86	MESAS ALTAS
LOUNGE CHAIRS	96	SILLONES
SOFAS 2	106	SOFÁS 2
SOFAS 3	116	SOFÁS 3
SECTIONALS	124	MODULARES
PUFS	162	PUFS
BAR STOOLS	170	TABURETES
SUNBEDS	178	TUMBONAS
SWINGS	190	COLUMPIOS
UMBRELLAS	194	PARASOLES
PLANTERS	198	JARDINERAS
LAMPS	204	LÁMPARAS
ACCESORIES	208	COMPLEMENTOS
INDOOR	212	MUEBLE DE INTERIOR
FINISHES	216	ACABADOS
PROJECTS	238	PROYECTOS

Designers

ALFONSO GALLEGO

CHRISTOPHE PILLET

ESTHER CAMPOS

ESTUDI(H)AC

FRANCESC RIFÉ

GABRIEL TEIXIDÓ

JOAQUÍN HOMS

JUAN SANTOS

MARIO RUIZ

VICENT MARTÍNEZ

XIMO ROCA

DESIGNERS



ALFONSO GALLEGO



CHRISTOPHE PILLET



ESTHER CAMPOS



GABRIEL TEIXIDÓ



JOAQUÍN HOMS



JUAN SANTOS



ESTUDI(H)AC



FRANCESC RIFÉ



MARIO RUIZ



VICENT MARTÍNEZ



XIMO ROCA

Chairs

AMBERES

ARC

CAMP

FENNEC

HERITAGE

MARINA

MONACO

PARALEL

ROUND

SUMMER

TANGER

TUB

U

WEAVE

WEEKEND

CHAIRS



AMBERES
Ref. 72201 | MOQ 10

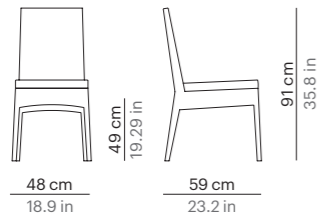

ARC
Ref. 76201 | NO MOQ

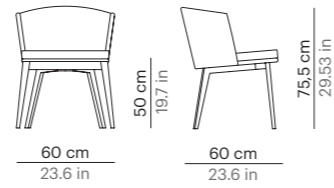

HERITAGE
Ref. 78601 | NO MOQ

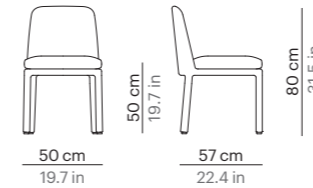

MARINA
Ref. 71001 | MOQ 10

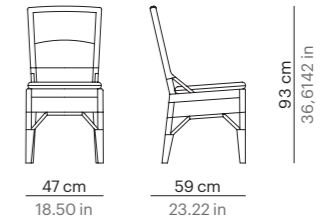

CAMP
Ref. 71901 | MOQ 10

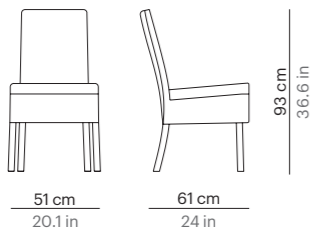

FENNEC
Ref. 74901 | MOQ 10

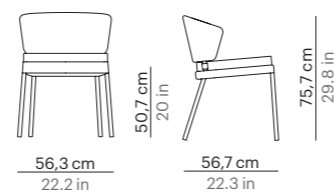

MONACO
Ref. 73601 | MOQ 10

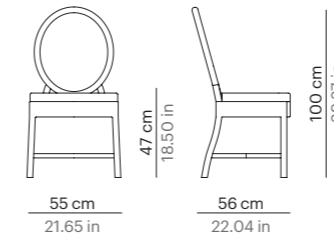

PARALEL
Ref. 77601 | NO MOQ

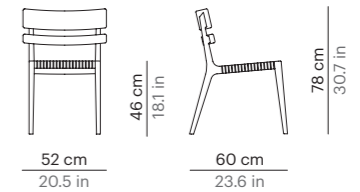

ROUND

Ref. 76501 | MOQ 10

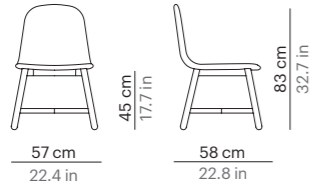

SUMMER

Ref. 77901 | NO MOQ

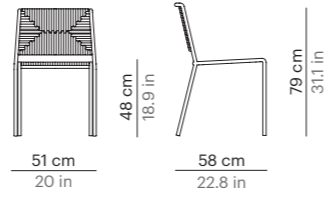

TANGER

Ref. 72601 | MOQ 10

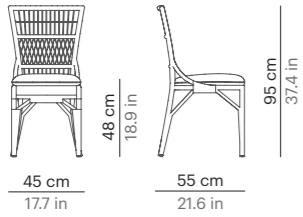

TUB

Ref. 74801 | MOQ 100

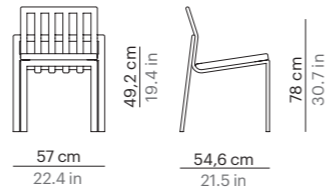

U

Ref. 74101 | NO MOQ

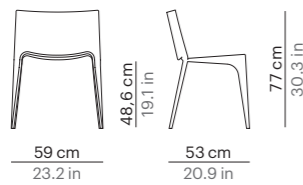

WEAVE

Ref. 77101 | NO MOQ

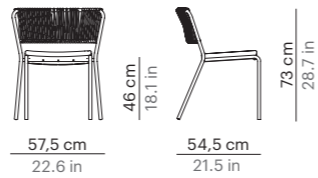

WEEKEND

Ref. 73102 | MOQ 100

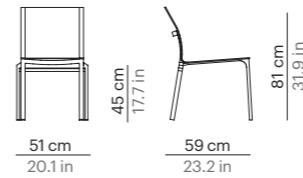

Armchairs

ALGA

AMBERES

ARC

BRIDGE

BUT

CADDIE

CAMP

CAPRI

CHARLESTON

CORAL

FENNEC

HAVANA

HAMP

HERITAGE

ICPALLI

ISLA

KHAI

LOLA

LLUM

MIN

MIRANDA

MONACO

OASIS

PARALEL

SAGRA

SUMMER

TUB

U

WEAVE

WEEKEND

ZEROS OUT

ARMCHAIRS



ALGA
Ref. 71006 | NO MOQ

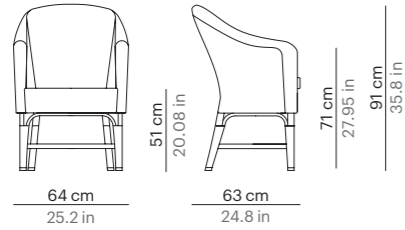

AMBERES
Ref. 72206 | MOQ 10

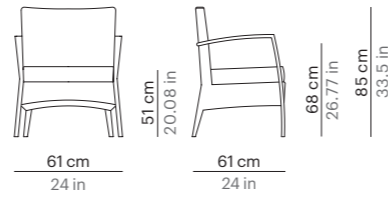

BUT
Ref. 77006 | MOQ 10

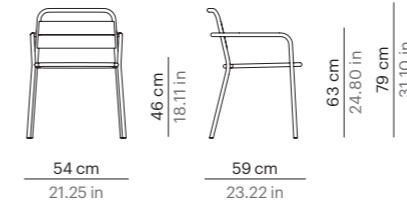

CADDIE
Ref. 71207 | NO MOQ

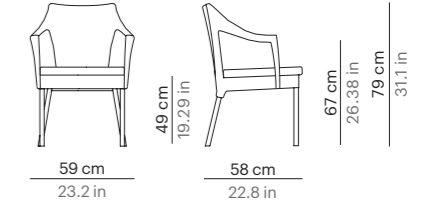

ARC
Ref. 76206 | NO MOQ

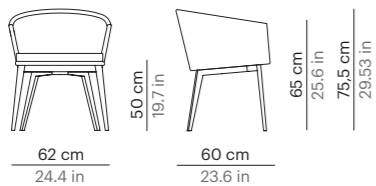

BRIDGE
Ref. 74001 | MOQ 10

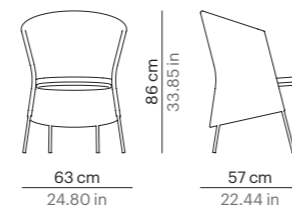

CAMP
Ref. 71906 | MOQ 10

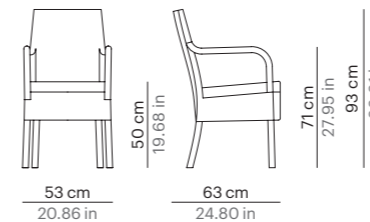

CAPRI
Ref. 70107 | MOQ 10

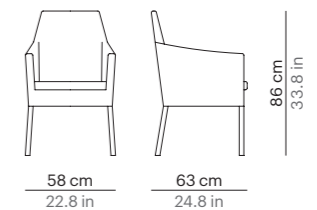

CHARLESTON
Ref. 73306 | NO MOQ

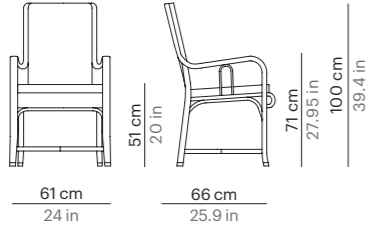

CORAL
Ref. 70006 | MOQ 10

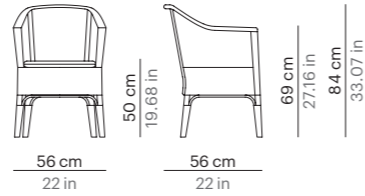

HERITAGE
Ref. 78506 | NO MOQ

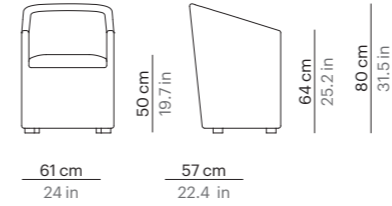

ICPALLI
Ref. 76007 | MOQ 10

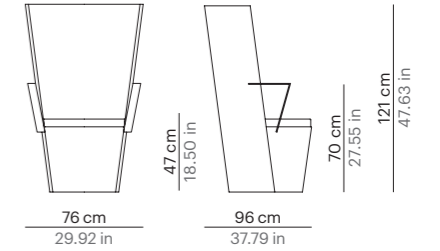

FENNEC
Ref. 74906 | MOQ 10

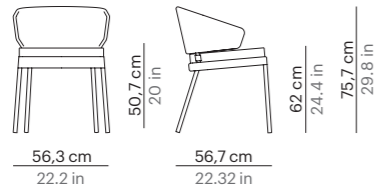

HAVANA
Ref. 73307 | NO MOQ

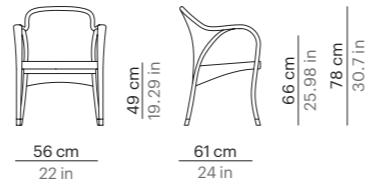

ISLA
Ref. 70007 | MOQ 10

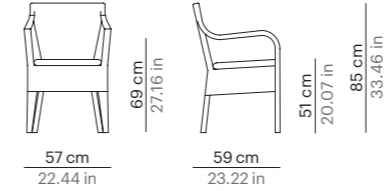

KHAI
Ref. 78806 | NO MOQ

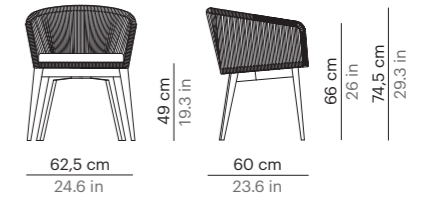

HAMP
Ref. 76706 | NO MOQ

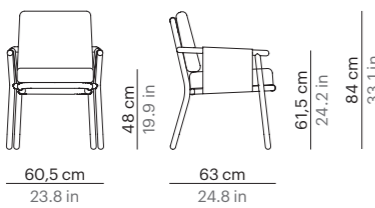

HERITAGE
Ref. 78606 | NO MOQ

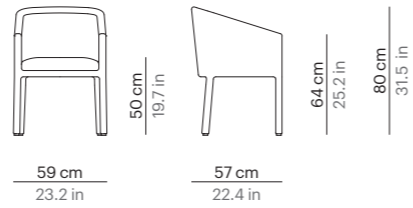

LOLA
Ref. 71606 | MOQ 10

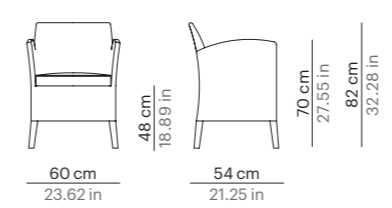

LLUM
Ref. 71608 | MOQ 10

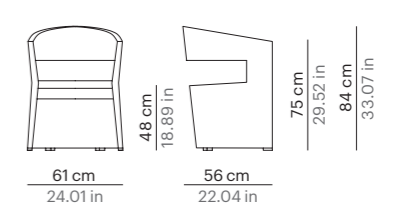

MIN

Ref. 77306 | NO MOQ

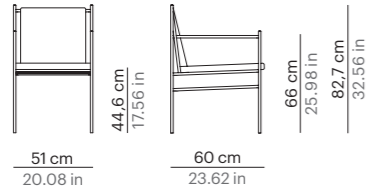

MIRANDA

Ref. 71607 | MOQ 10

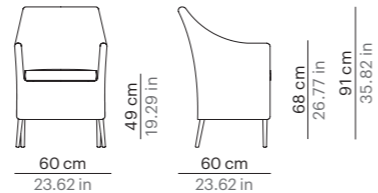

SUMMER

Ref. 77906 | NO MOQ

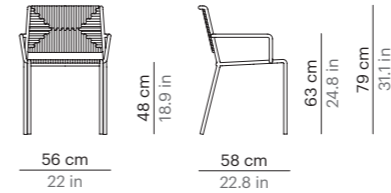

TUB

Ref. 74806 | MOQ 100

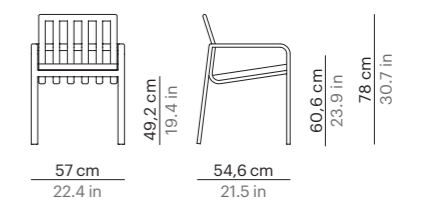

MONACO

Ref. 73606 | MOQ 10

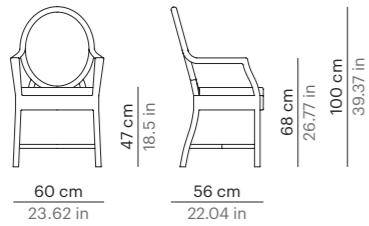

OASIS

Ref. 72606 | MOQ 10

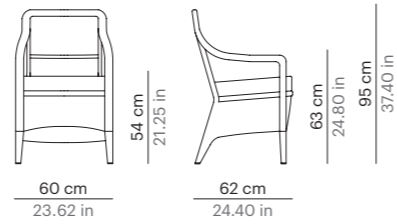

U

Ref. 74106 | NO MOQ

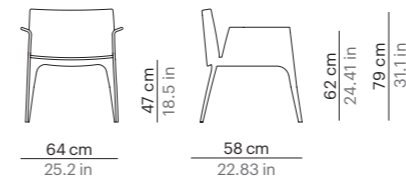

WEAVE

Ref. 77107 | NO MOQ

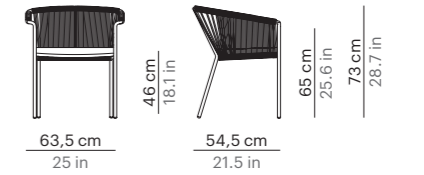

PARALEL

Ref. 77606 | NO MOQ

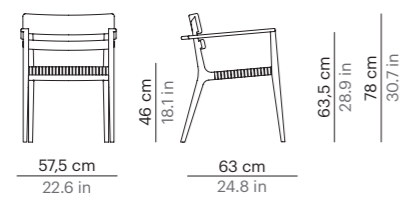

SAGRA

Ref. 70106 | NO MOQ

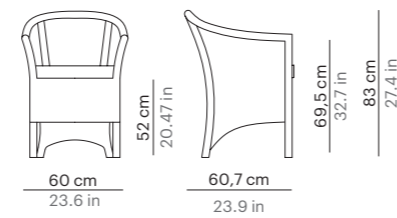

WEAVE

Ref. 77105 | NO MOQ

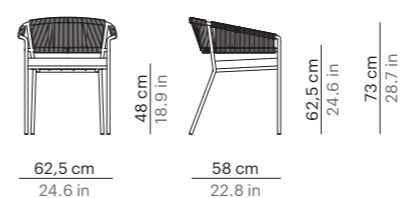

WEEKEND

Ref. 73103 | MOQ 100

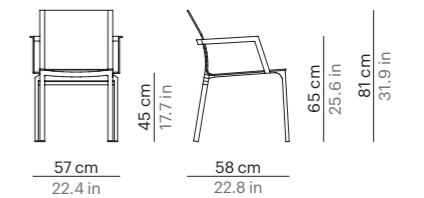

ZEROS OUT 
Ref. 76806 | MOQ 10



55,5 cm
21.85 in



45,5 cm
17.91 in



50 cm
19.68 in



70 cm
27.55 in



75 cm
29.52 in

Small Lounge Chairs

ALTEA

ARC

FENNEC

HERITAGE

MARILYN XL

MARILYN X

PARALEL

PUL

ROUND

T

U

WEAVE

SMALL LOUNGE CHAIRS



ALTEA
Ref. 74607 | MOQ 10

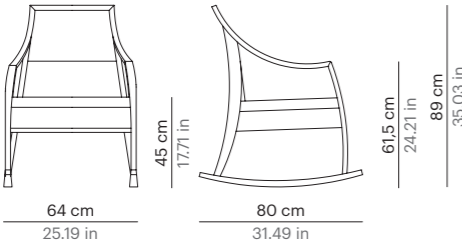

ARC
Ref. 76207 | NO MOQ

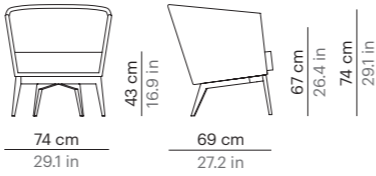

MARILYN XL
Ref. 74007 | MOQ 10

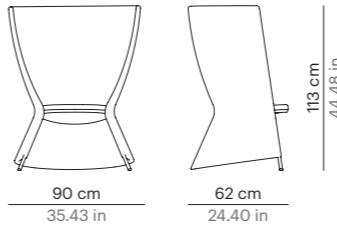

MARILYN X
Ref. 74006 | MOQ 10

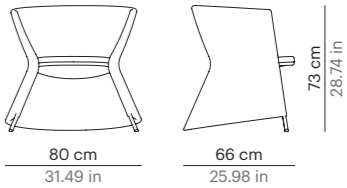

FENNEC
Ref. 74946 | MOQ 10

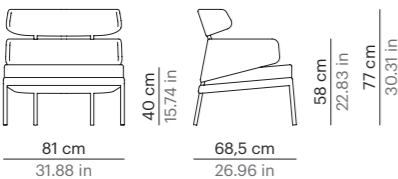

HERITAGE
Ref. 78705 | NO MOQ

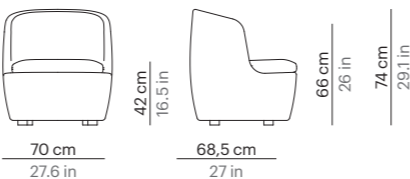

PARALEL
Ref. 77605 | NO MOQ

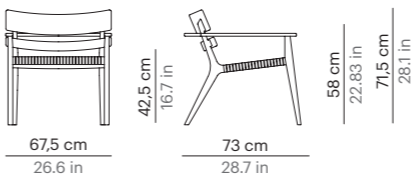

PUL
Ref. 76607 | MOQ 10

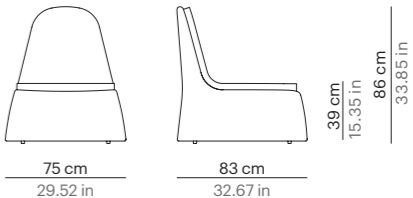



ROUND

Ref. 76544 | MOQ 5

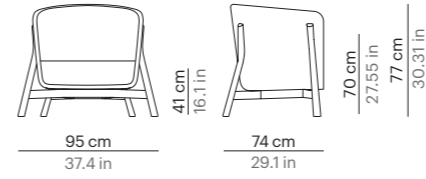

T

Ref. 77407 | MOQ 50

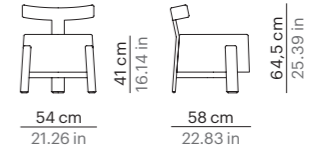

U

Ref. 74246 | MOQ 10

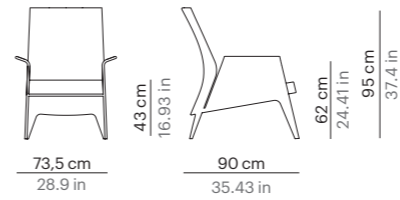

U

Ref. 74107 | MOQ 10



WEAVE

Ref. 77108 | NO MOQ

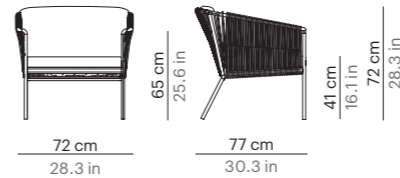

PROJECTS

RANCHO PUNTA MITA

MEXICO
HAMP, U, GOLF,
LINEAL COLLECTIONS

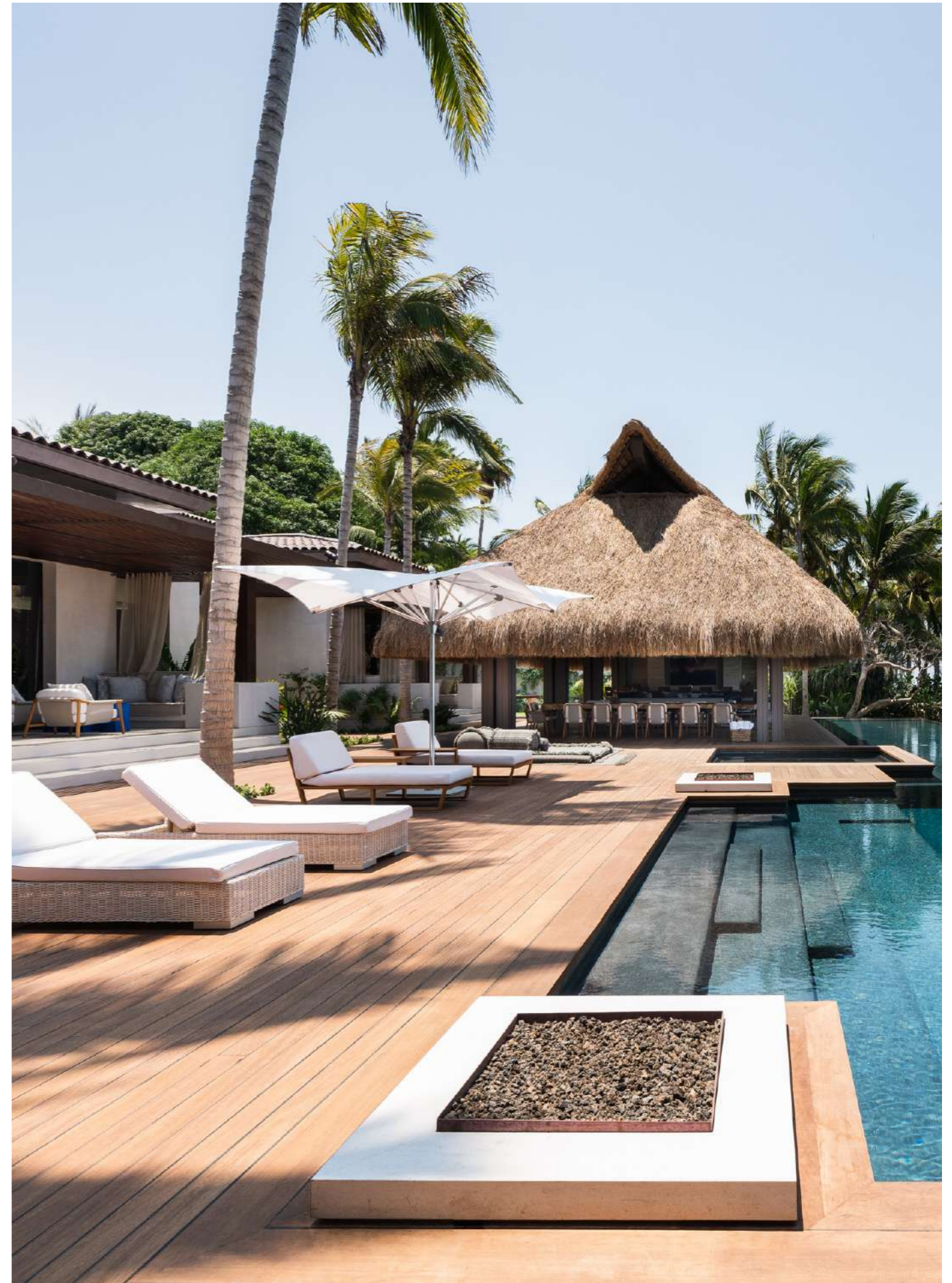







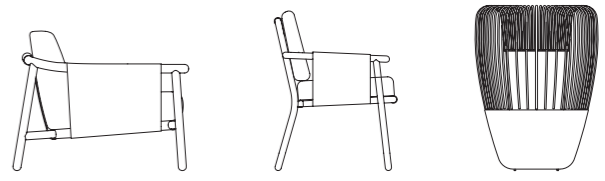

Dining Tables

ALGA

AMBERES

ANGUL

ARC

COLORS

FENNEC

GOLF

HAMP

HAVANA

HERITAGE

LOLA

MARYLIN

MONACO

MIN

PARALEL

ROUND

SUMMER

TUB

U

WEAVE

WEEKEND

DINING TABLES



ALGA
Ref. 71014 | NO MOQ

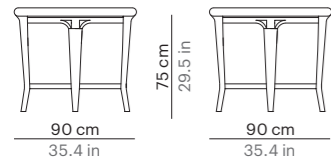

ALGA
Ref. 71010 | NO MOQ

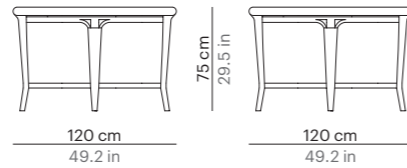

AMBERES
Ref. 72211 | MOQ 10

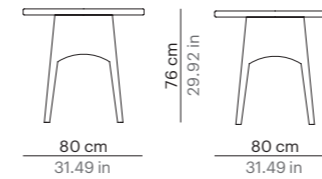

ALGA
Ref. 70010 | MOQ 10

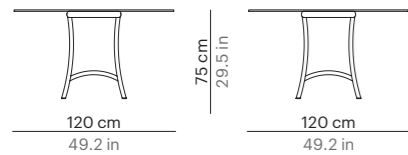

ALGA
Ref. 70009 | MOQ 10

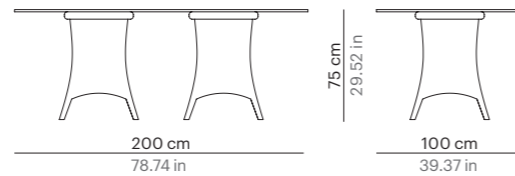

AMBERES
Ref. 72210 | MOQ 10

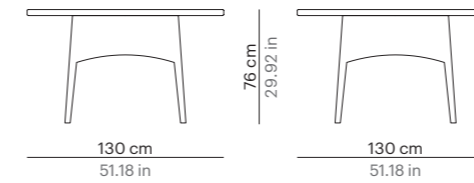

AMBERES
Ref. 72209 | MOQ 10

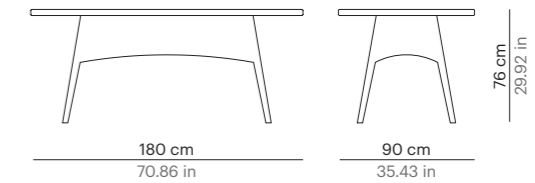

AMBERES
Ref. 72208 | MOQ 10

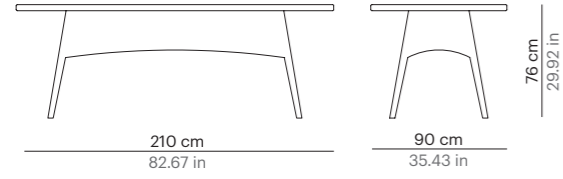

ANGUL
Ref. 72310 | MOQ 5

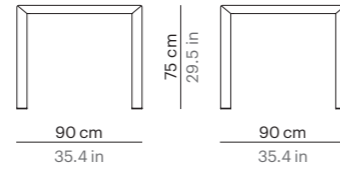

COLORS
Ref. 7421409 | NO MOQ

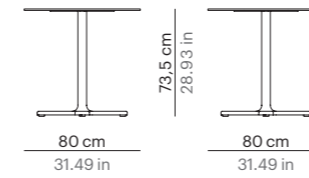

COLORS
Ref. 7421407 | NO MOQ

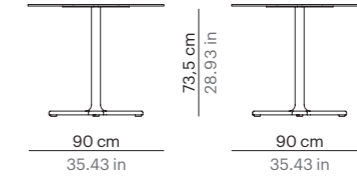

ANGUL
Ref. 72309 | MOQ 5

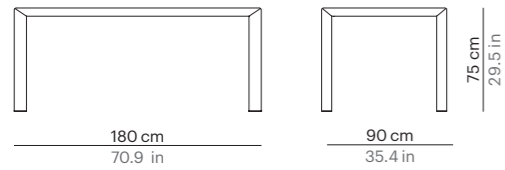

ARC
Ref. 76210 | MOQ 5

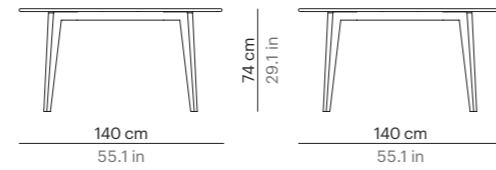

COLORS
Ref. 7421415 | NO MOQ

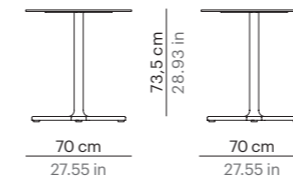

COLORS
Ref. 7421410 | NO MOQ

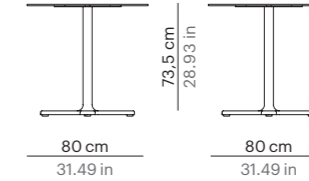

ARC
Ref. 76209 | MOQ 5

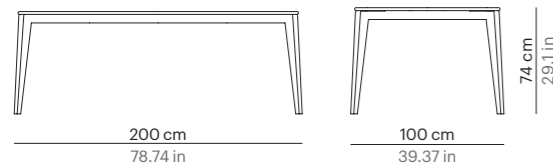

COLORS
Ref. 7421414 | NO MOQ

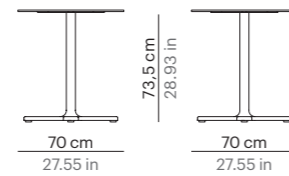

COLORS
Ref. 7421411 | NO MOQ

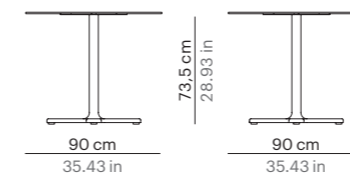

COLORS
Ref. 7420808 | NO MOQ

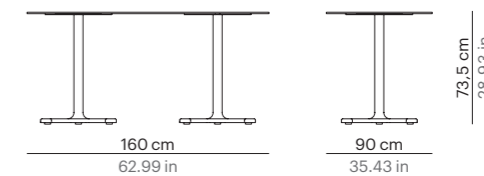

FENNEC
Ref. 74910 | MOQ 5

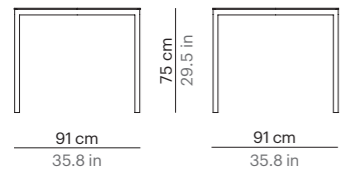

FENNEC
Ref. 74909 | MOQ 10

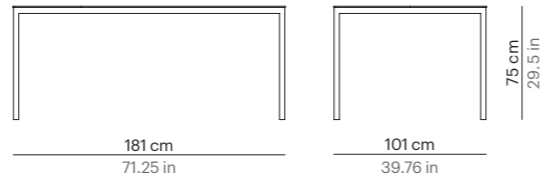

HAVANA
Ref. 73314 | MOQ 10

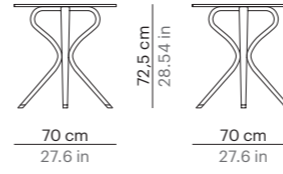

HERITAGE
Ref. 78511 | NO MOQ

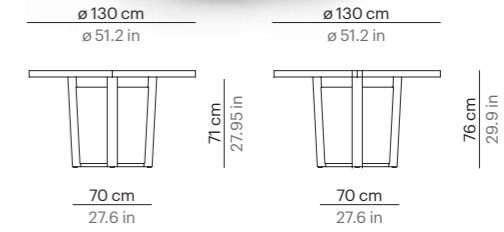

FENNEC
Ref. 74908 | MOQ 5

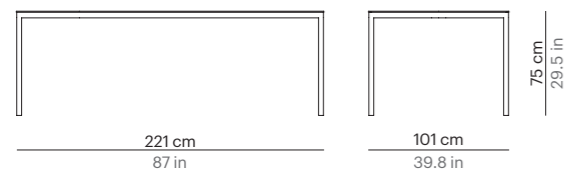

GOLF
Ref. 71510 | MOQ 10

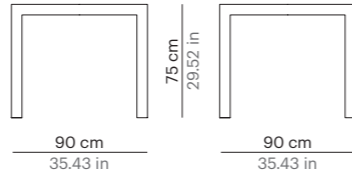

HERITAGE
Ref. 78510 | NO MOQ

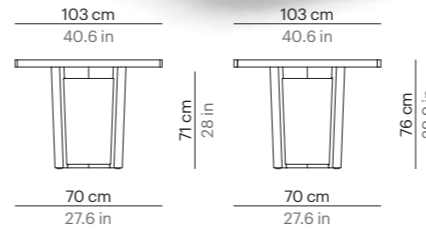

HERITAGE
Ref. 78508 | NO MOQ

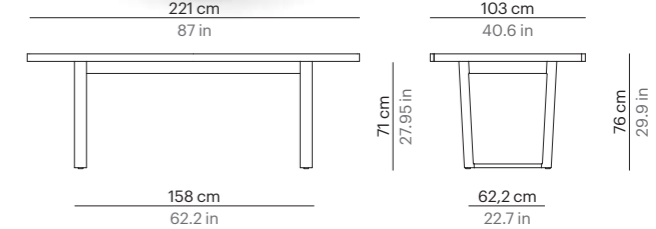

GOLF
Ref. 71509 | MOQ 10

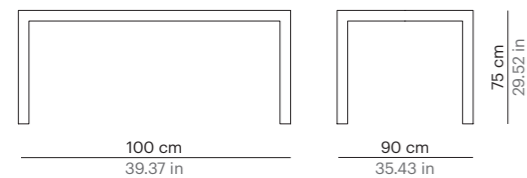

HAMP
Ref. 76709 | MOQ 5

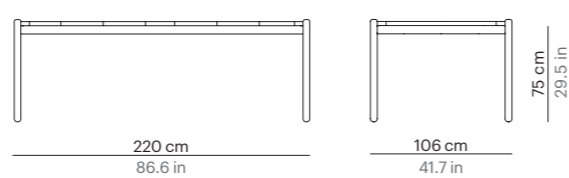

HERITAGE
Ref. 78509 | NO MOQ

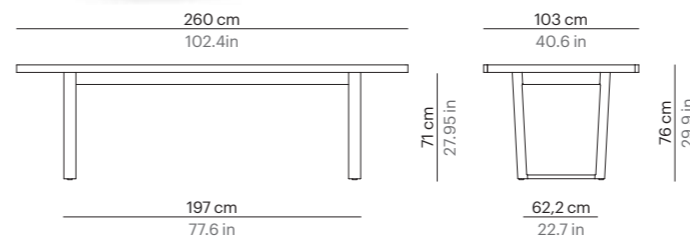

LOLA
Ref. 71610 | MOQ 10

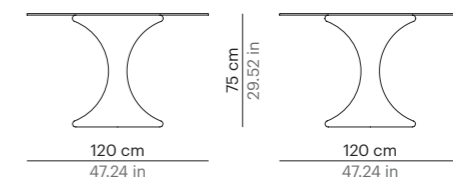

MARYLIN
Ref. 74010 | MOQ 10

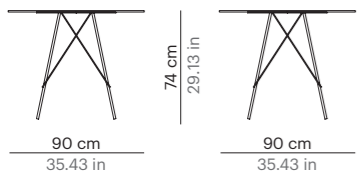

MARYLIN
Ref. 74009 | MOQ 10

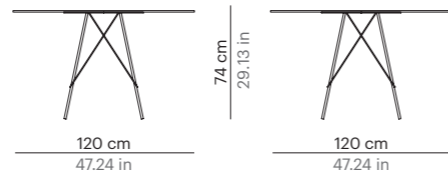

MONACO
Ref. 73609 | MOQ 10

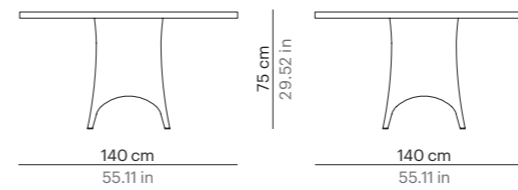

MIN
Ref. 77310 | MOQ 30

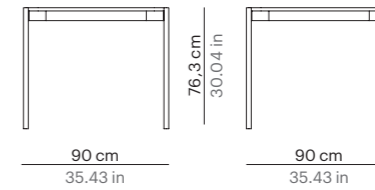

MARYLIN
Ref. 74008 | MOQ 10

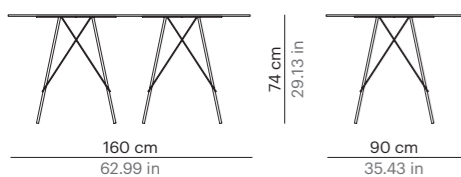

MONACO
Ref. 73610 | MOQ 10

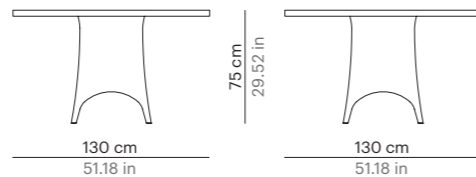

MIN
Ref. 77309 | MOQ 30

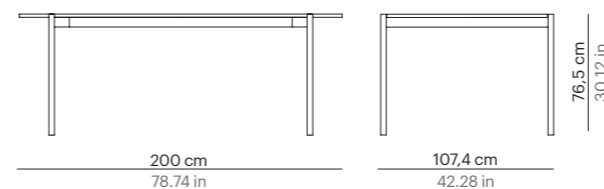

PARALEL
Ref. 77610 | NO MOQ

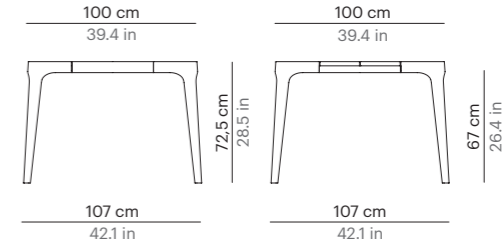

MONACO
Ref. 73608 | MOQ 10

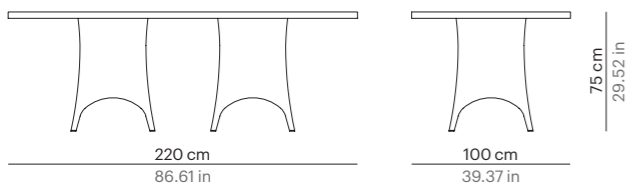

MONACO
Ref. 73611 | MOQ 10

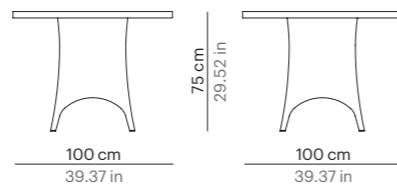

PARALEL
Ref. 77611 | NO MOQ

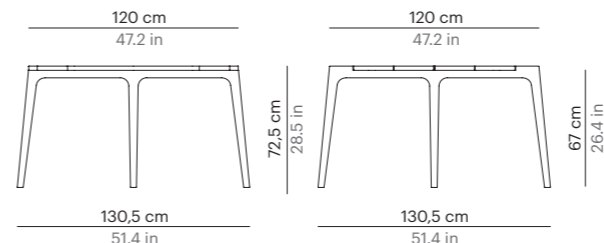

PARALEL
Ref. 77608 | NO MOQ

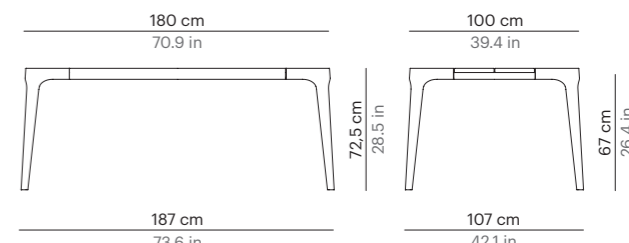

PARALEL
Ref. 77609 | NO MOQ

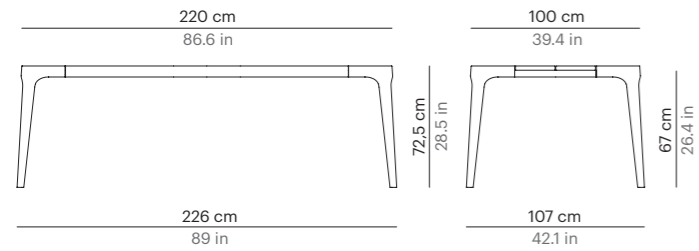

PARALEL
Ref. 77607 | NO MOQ

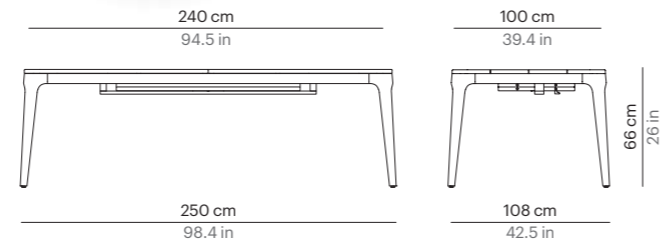

ROUND
Ref. 76507 | MOQ 5

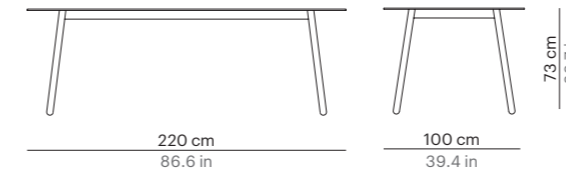

SUMMER
Ref. 77910 | NO MOQ

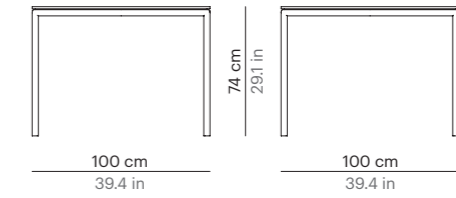

ROUND
Ref. 76517 | MOQ 5

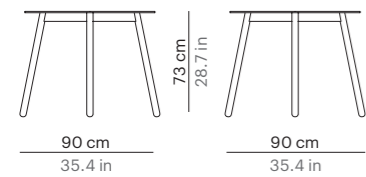

ROUND
Ref. 76515 | MOQ 5

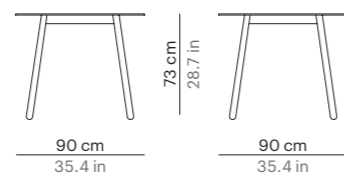

SUMMER
Ref. 77908 | NO MOQ

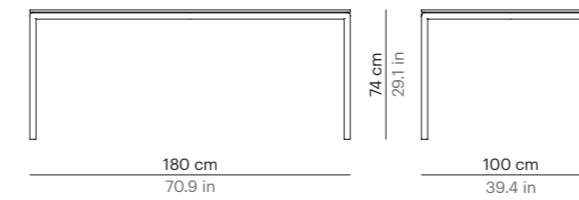

SUMMER
Ref. 77909 | NO MOQ

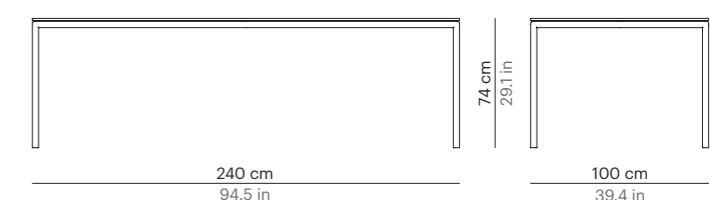

ROUND
Ref. 76513 | MOQ 5

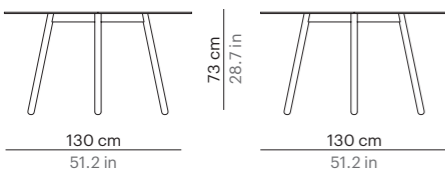

ROUND
Ref. 76509 | MOQ 5

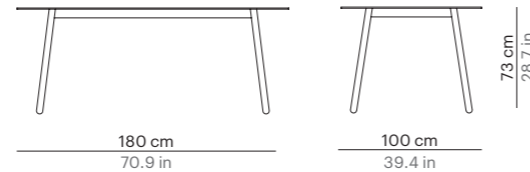

TUB
Ref. 74810 | MOQ 30

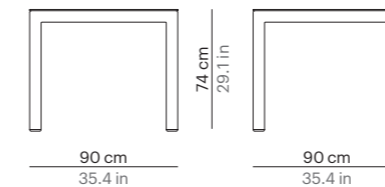

TUB
Ref. 74809 | MOQ 30

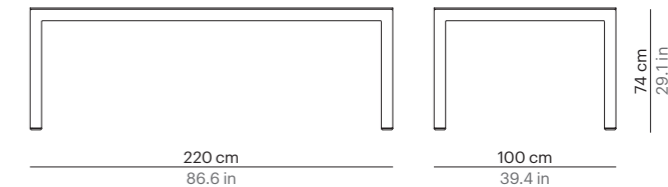

WEAVE
Ref. 7811401 | NO MOQ

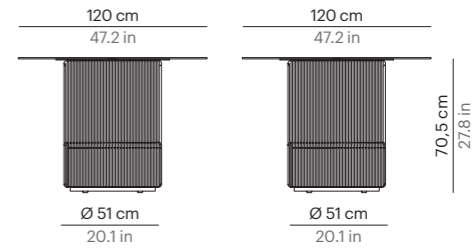

WEAVE
Ref. 7711510 | NO MOQ

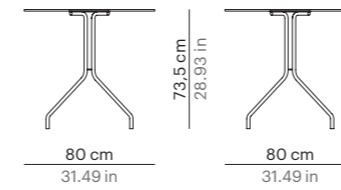

WEEKEND
Ref. 73110 | MOQ 50

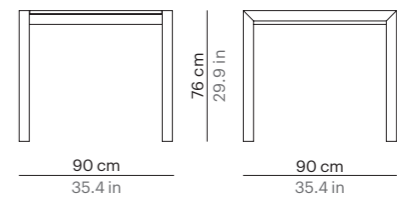

WEAVE
Ref. 7811402 | NO MOQ

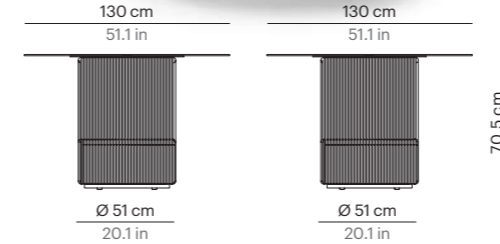

WEEKEND
Ref. 73109 | MOQ 30

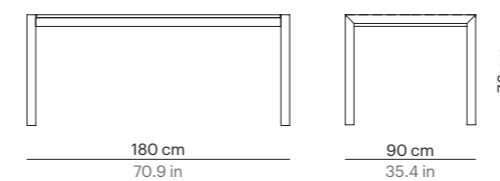

WEEKEND
Ref. 73108 | MOQ 30

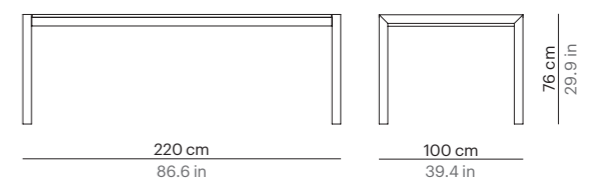

U
Ref. 74109 | MOQ 5

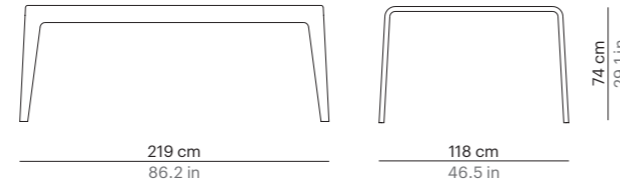

WEAVE
Ref. 7711509 | NO MOQ

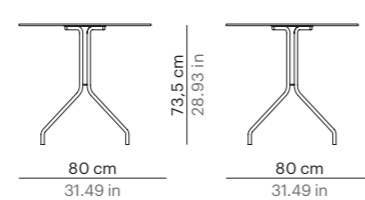

WEAVE
Ref. 7711515 | NO MOQ

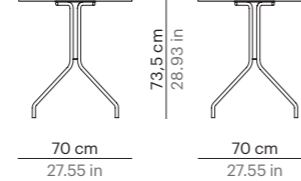

POINT
U
Ref. 74110 | MOQ 5

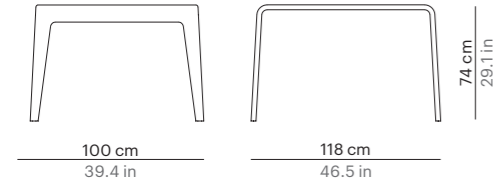

WEAVE
Ref. 7711514 | NO MOQ

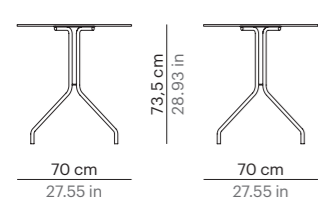

WEAVE
Ref. 7710908 | NO MOQ

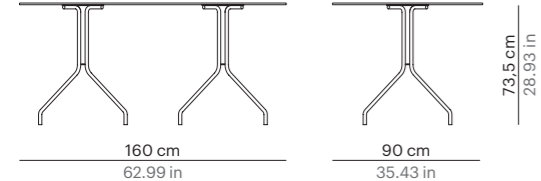

Coffee Tables

ARC

ARENA

BOX

CASABLANCA

CITY

DIABOLO

GREEN

HAMP

HERITAGE

ICPALLI

KENYA

LINEAL

LONG ISLAND

MIN

PAL

PARALEL

PUL

ROUND

RUEDO

T

TUB

U

VELETTA

WEAVE

WEEKEND

COFFEE TABLES



ARC
Ref. 76254 | NO MOQ

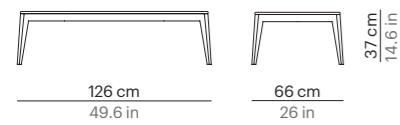

ARENA
Ref. 70053 | NO MOQ

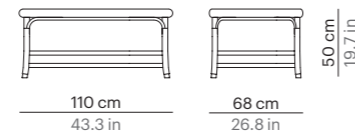

CASABLANCA
Ref. 72754 | MOQ 10

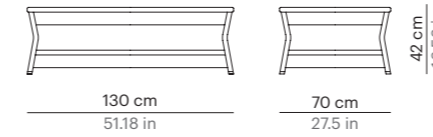

CITY
Ref. 78353 | NO MOQ

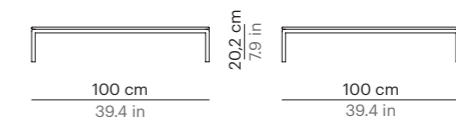

BOX
Ref. 71454 | MOQ 10

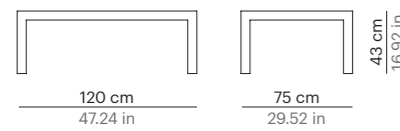

CASABLANCA
Ref. 72753 | MOQ 10

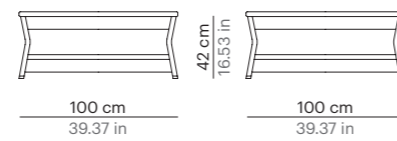

CITY
Ref. 78354 | NO MOQ

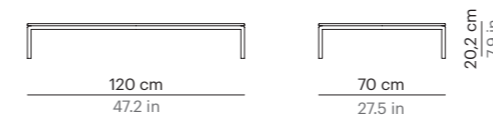

DIABOLO
Ref. 74154 | MOQ 10

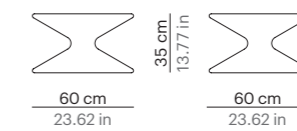

DIABOLO
Ref. 74155 | MOQ 10

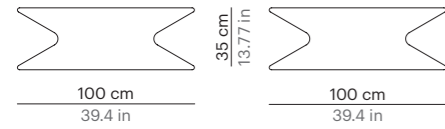

DIABOLO
Ref. 74156 | MOQ 10

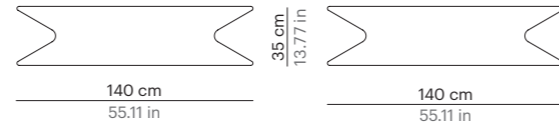

HAMP
Ref. 76754 | MOQ 5

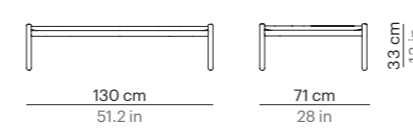

HERITAGE
Ref. 78554 | NO MOQ

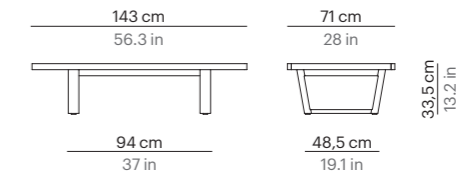

FENNEC
Ref. 74953 | MOQ 10

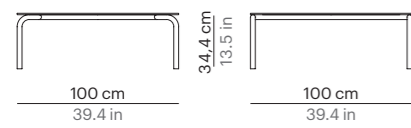

FENNEC
Ref. 74954 | MOQ 10

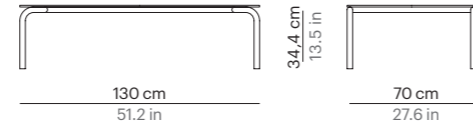

HERITAGE
Ref. 78553 | NO MOQ

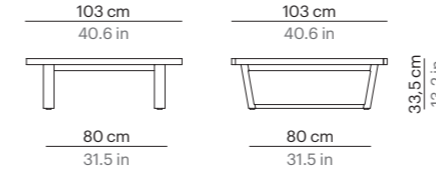

HERITAGE
Ref. 78753 | NO MOQ

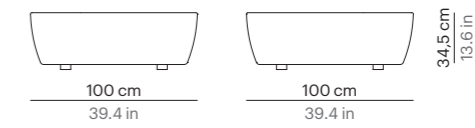

GREEN
Ref. 72653 | MOQ 10

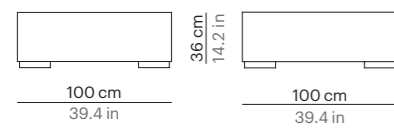

GREEN
Ref. 72654 | MOQ 10

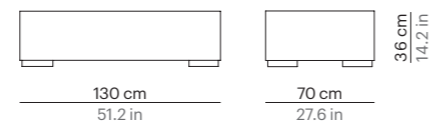

HERITAGE
Ref. 78755 | NO MOQ

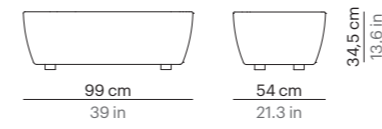

ICPALLI
Ref. 76053 | MOQ 10

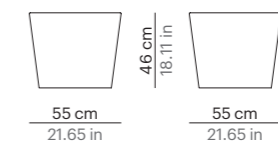

KENYA
Ref. 73454 | MOQ 10

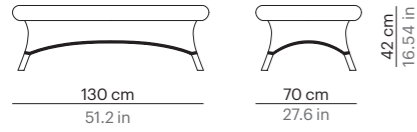

LINEAL
Ref. 76354 | MOQ 5

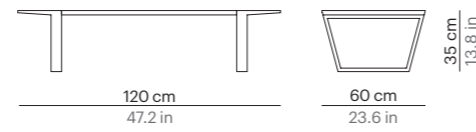

PAL
Ref. 77050 | NO MOQ

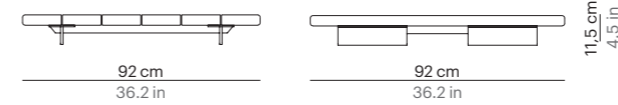

LONG ISLAND
Ref. 77854 | NO MOQ

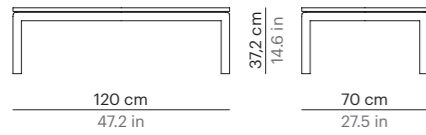

LONG ISLAND
Ref. 77853 | NO MOQ

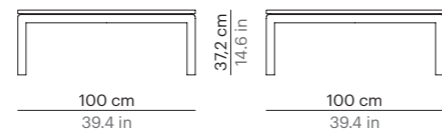

PAL
Ref. 77055 | NO MOQ

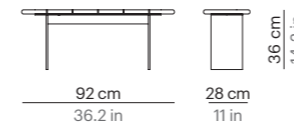

PAL
Ref. 77051 | NO MOQ

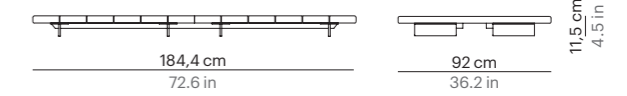

MIN
Ref. 77354 | MOQ 80

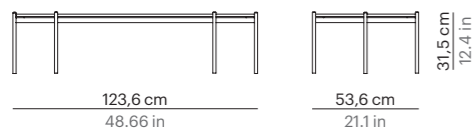

MIN
Ref. 77353 | MOQ 80

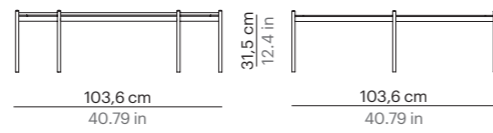

PAL
Ref. 77053 | NO MOQ

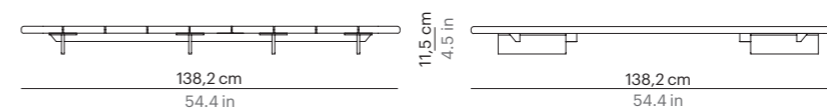

PAL
Ref. 77052 | NO MOQ

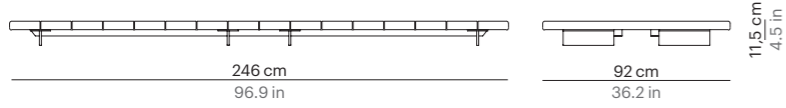

PAL
Ref. 77057 | NO MOQ

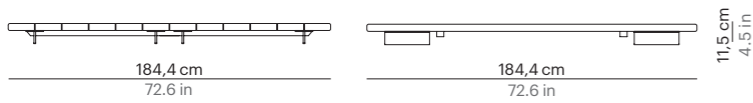

PAL
Ref. 77054 | NO MOQ

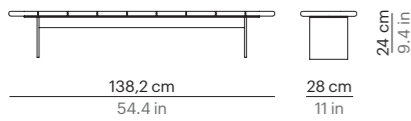

PAL
Ref. 77054 | NO MOQ

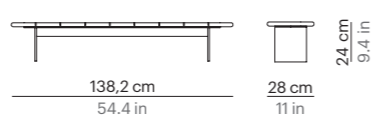

PARALEL
Ref. 77654 | NO MOQ

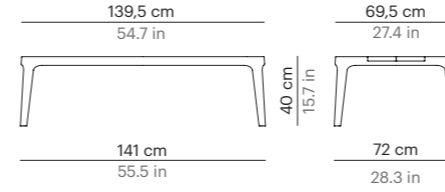

ROUND
Ref. 76555 | NO MOQ

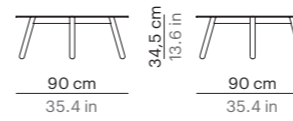

PUL
Ref. 76653 | MOQ 10

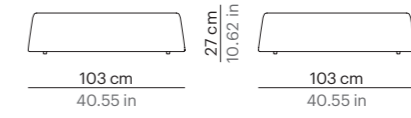

ROUND
Ref. 76553 | NO MOQ

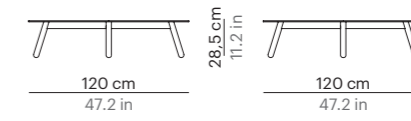

RUEDO
Ref. 71653 | MOQ 10

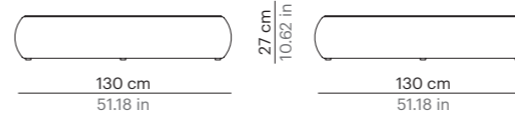

T
Ref. 77456 | MOQ 50

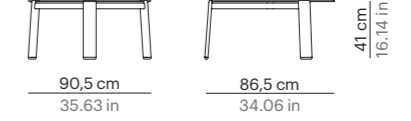

TUB
Ref. 74854 | MOQ 50

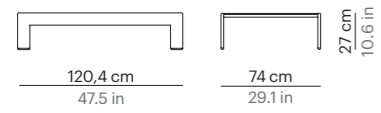

U
Ref. 74253 | MOQ 5

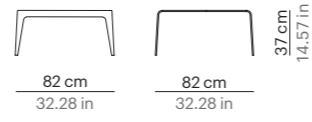

WEAVE
Ref. 77153 | MOQ 10

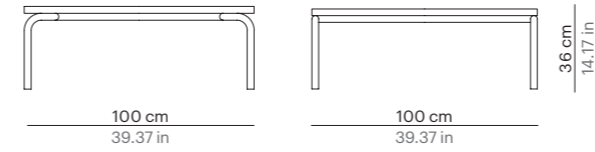

WEAVE
Ref. 77154 | MOQ 10

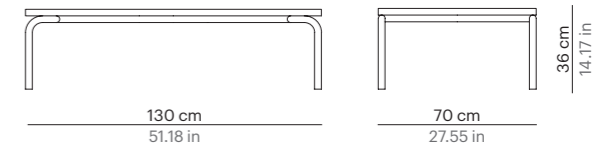

U
Ref. 74254 | MOQ 5

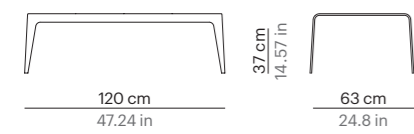

U
Ref. 74255 | MOQ 5

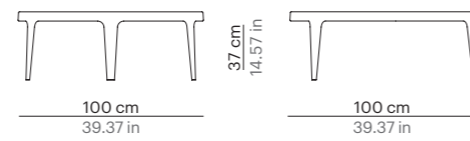

WEAVE
Ref. 7715814 | MOQ 50

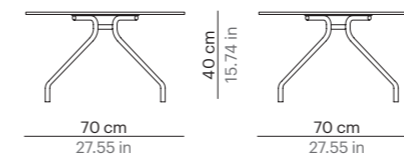

WEAVE
Ref. 7715809 | MOQ 50

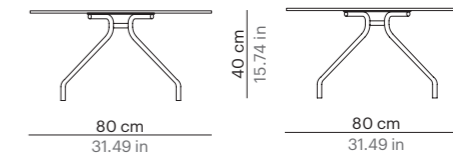

U
Ref. 74114 | MOQ 5

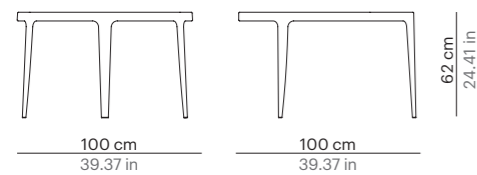

VELETTA
Ref. 73653 | MOQ 10

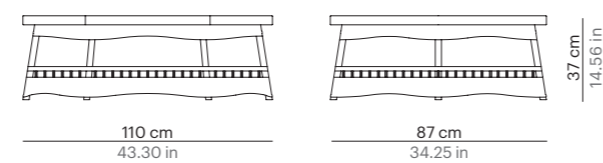

WEAVE
Ref. 7715807 | MOQ 50

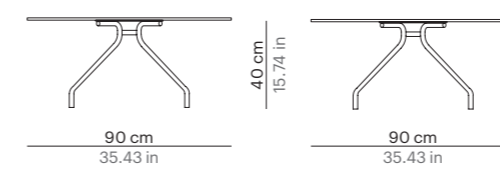

WEAVE
Ref. 7715815 | MOQ 50

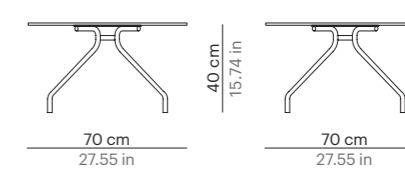

WEAVE
Ref. 7715810 | MOQ 50

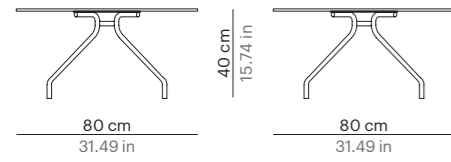

WEAVE
Ref. 7715811 | MOQ 50

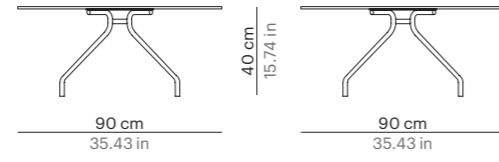

WEAVE
Ref. 7715808 | MOQ 50

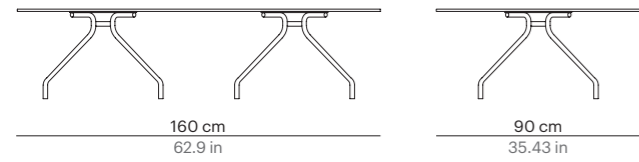
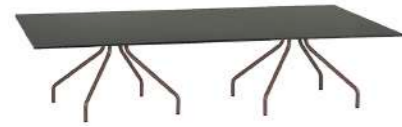

WEAVE
Ref. 78153 | NO MOQ

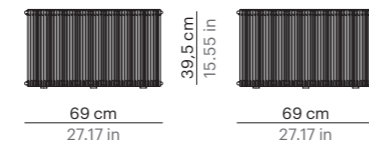

WEAVE
Ref. 78159 | NO MOQ

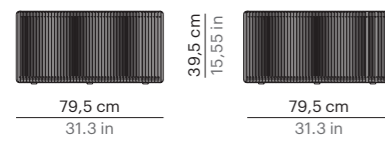

WEEKEND
Ref. 73154 | MOQ 50

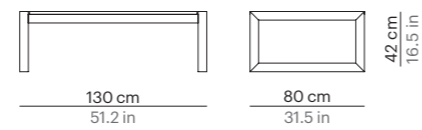

PROJECTS

THE OBELISK SOFITEL

DUBAI
WEAVE, DALMATIA
COLLECTIONS





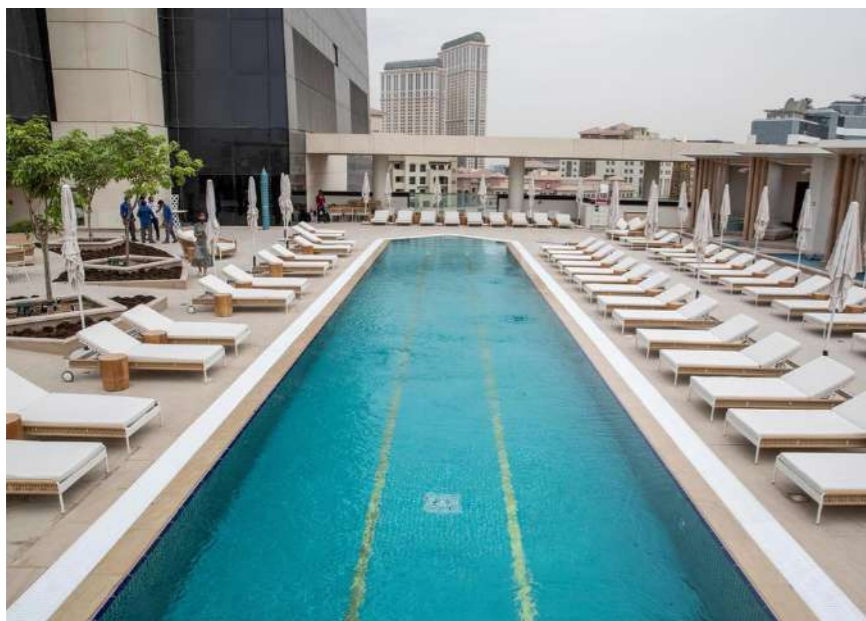

Side Tables

ARC

ARENA

BAY

BOX

BREDA

BUBBLE

CASABLANCA

CHARLESTON

CITY

EMMANUEL

FENNEC

GREEN

HAMP

HERITAGE

ICPALLI

JAZZ

KENYA

LINEAL

LIS

LONG ISLAND

MARYLIN

MIN

PARALEL

PUL

ROUND

RUEDO

TUB

U

VELETTA

WEAVE

WEEKEND

ZOE

SIDE TABLES



ARC
Ref. 76256 | NO MOQ

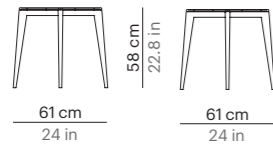

ARENA
Ref. 70056 | NO MOQ

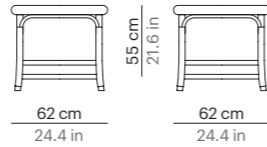

BOX
Ref. 71493 | MOQ 10

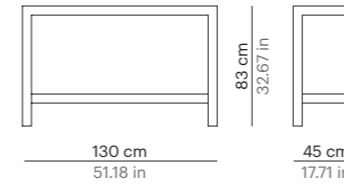

BREDA
Ref. 72058 | NO MOQ

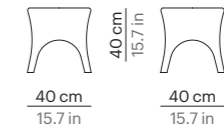

BAY
Ref. 78458 | NO MOQ

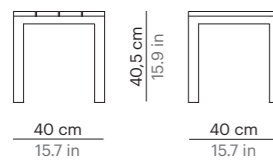

BOX
Ref. 71456 | MOQ 10

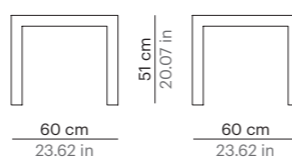

BUBBLE
Ref. 72456 | NO MOQ

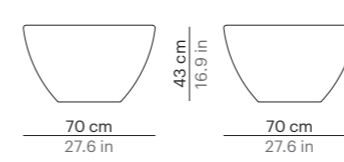

CASABLANCA
Ref. 72756 | MOQ 10

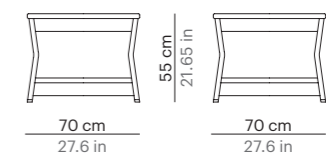

CHARLESTON
Ref. 73315 | MOQ 5

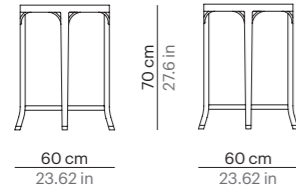

CITY
Ref. 78357 | NO MOQ

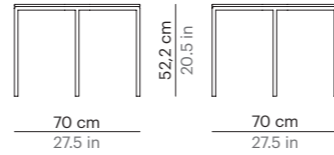

HAMP
Ref. 76756 | MOQ 5

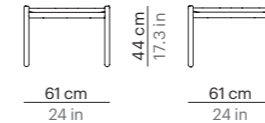

HERITAGE
Ref. 78556 | NO MOQ

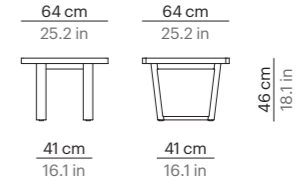

CITY
Ref. 78356 | NO MOQ

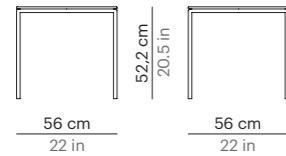

EMMANUEL
Ref. 73214 | MOQ 5

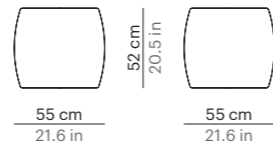

HERITAGE
Ref. 78555 | NO MOQ

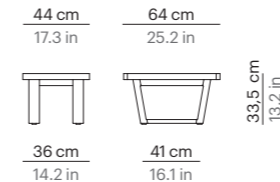

HERITAGE
Ref. 78756 | NO MOQ

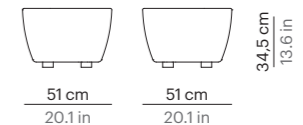

FENNEC
Ref. 74956 | MOQ 10

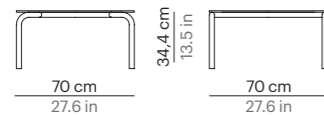

GREEN
Ref. 72656 | MOQ 10

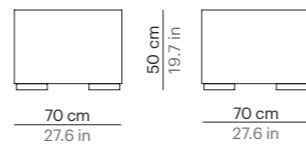

ICPALLI
Ref. 76058 | MOQ 10

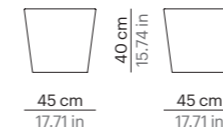

JAZZ
Ref. 73958 | NO MOQ

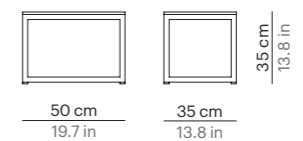

KENYA
Ref. 73456 | MOQ 5

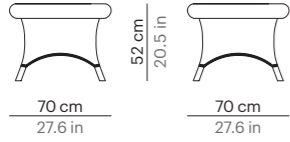

LINEAL
Ref. 76358 | MOQ 5

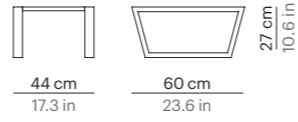

LIS
Ref. 7825402 | NO MOQ

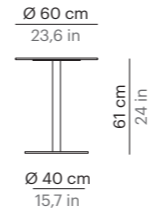

LONG ISLAND
Ref. 77856 | NO MOQ

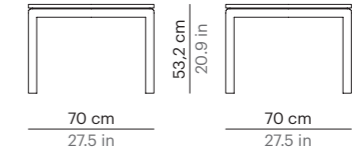

LINEAL
Ref. 76356 | MOQ 5

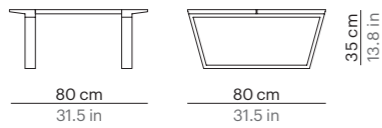

LIS
Ref. 7825301 | NO MOQ

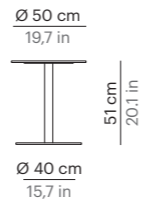

MARYLIN
Ref. 74014 | MOQ 10

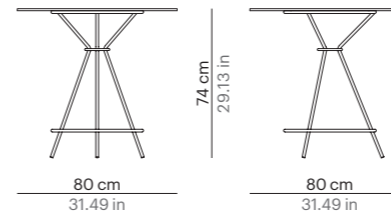

MARYLIN
Ref. 74015 | MOQ 10

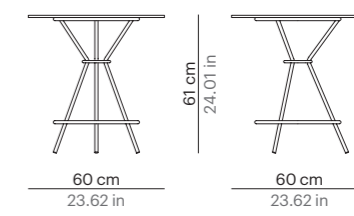

LIS
Ref. 7825302 | NO MOQ

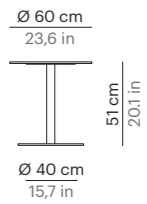

LIS
Ref. 7825401 | NO MOQ

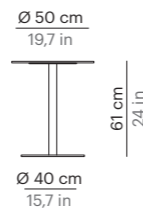

MIN
Ref. 77356 | MOQ 80

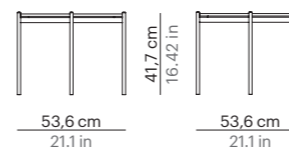

PARALEL
Ref. 77656 | NO MOQ

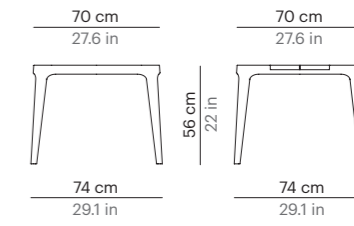

PARALEL

Ref. 77615 | NO MOQ

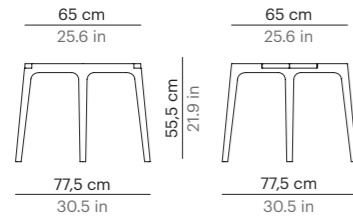

PARALEL

Ref. 77658 | NO MOQ

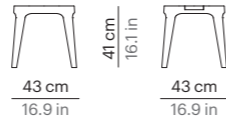

PUL

Ref. 76658 | MOQ 10

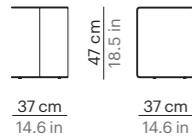

PUL

Ref. 76657 | MOQ 10

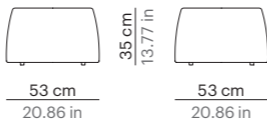

PUL

Ref. 76656 | MOQ 10

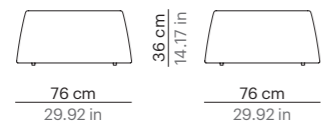

ROUND

Ref. 76557 | NO MOQ

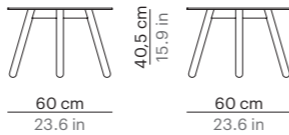

RUEDO

Ref. 71656 | MOQ 10

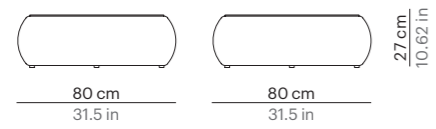

TUB

Ref. 74856 | MOQ 50

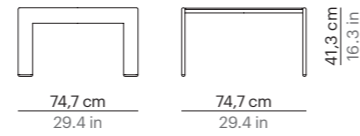

WEAVE

Ref. 78156 | NO MOQ

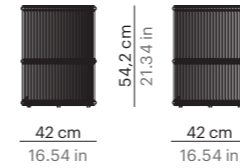

WEEKEND

Ref. 73159 | MOQ 50

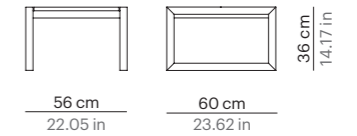

U

Ref. 74258 | MOQ 5

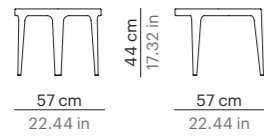

U

Ref. 74115 | MOQ 5

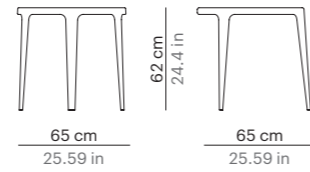

ZOE

Ref. 72156 | MOQ 10

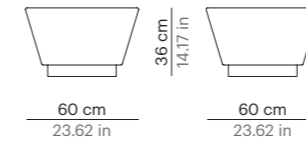

VELETTA

Ref. 73656 | MOQ 10

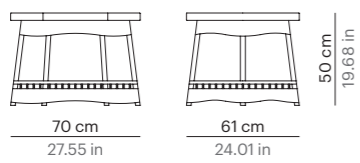

WEAVE

Ref. 77156 | MOQ 10

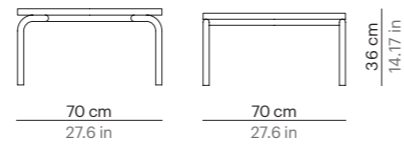

High Tables

U
WEAVE

HIGH TABLES

U
Ref. 74116 | MOQ 5

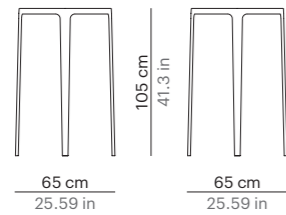

WEAVE
Ref. 7711215 | NO MOQ

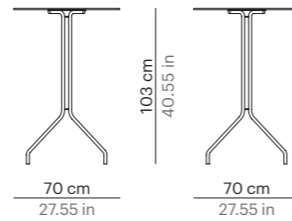

WEAVE
Ref. 7711209 | NO MOQ

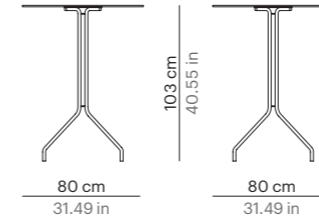

WEAVE
Ref. 7711208 | NO MOQ

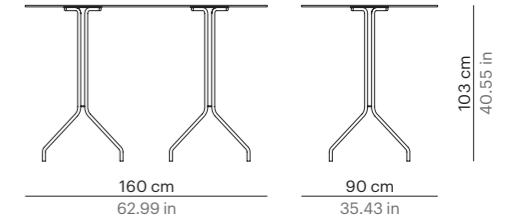

WEAVE
Ref. 7711214 | NO MOQ

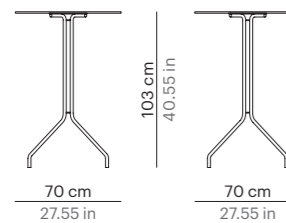

WEAVE
Ref. 7711210 | NO MOQ

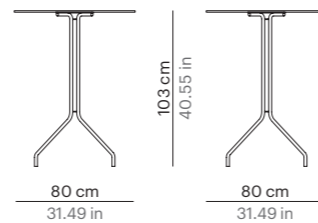

WEAVE
Ref. 7711211 | NO MOQ

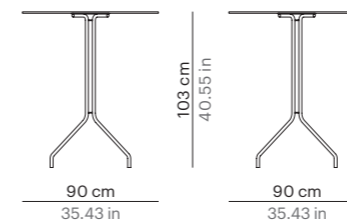

WEAVE
Ref. 7711207 | NO MOQ

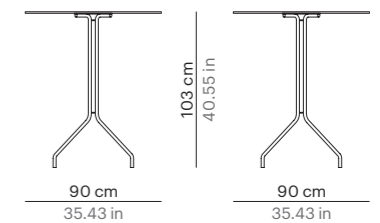

PROJECTS

SHAN GRI-LA HOTEL

FRANCE
U, BUBBLE, ROMANTIC
COLLECTIONS

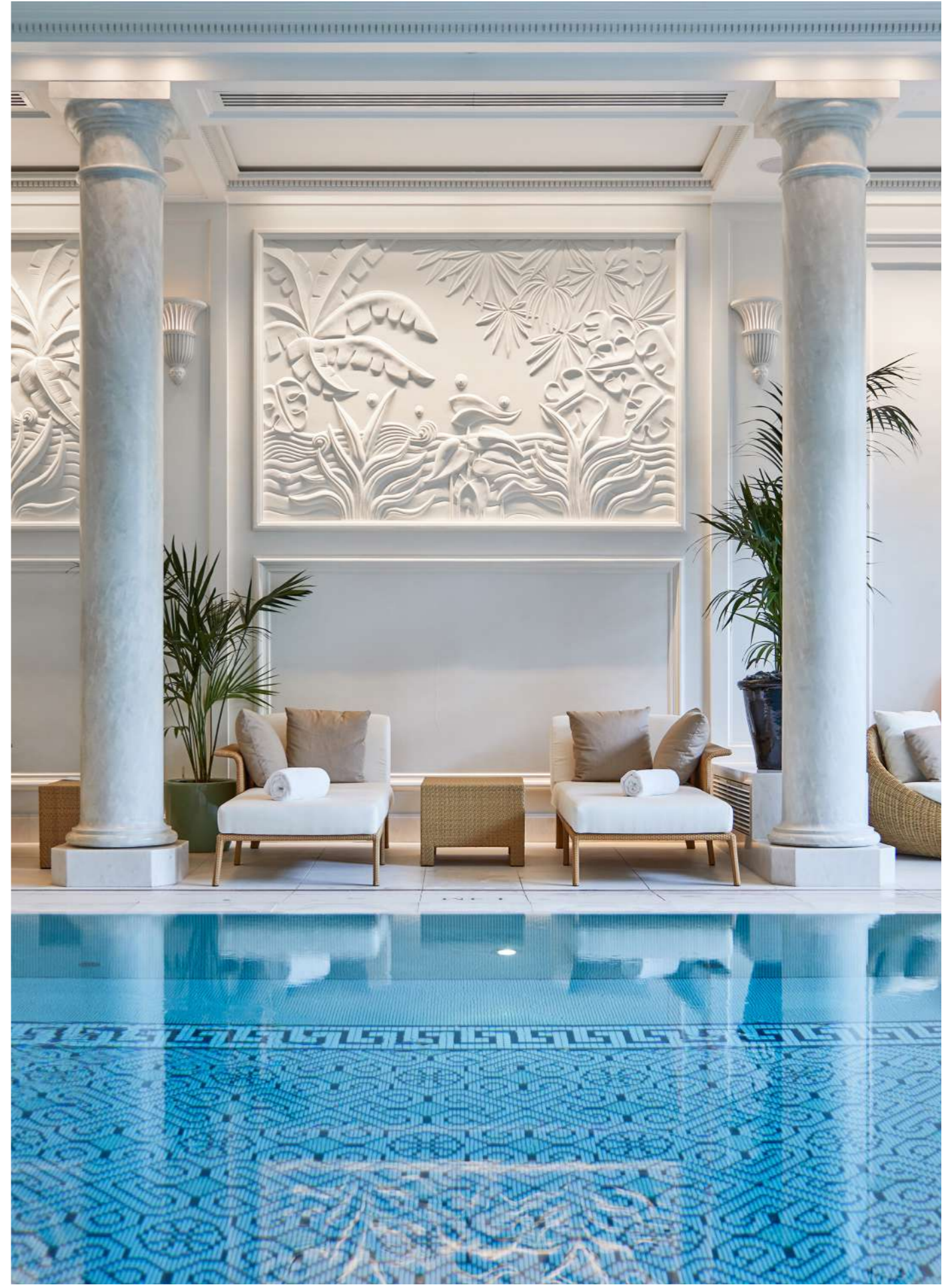



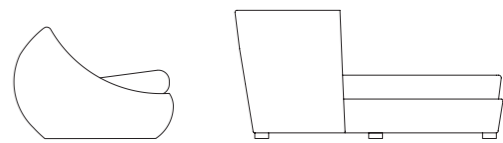

Lounge Chairs

ALOS

ARC

ARENA

BOX

BUBBLE

BRUMAS

CASABLANCA

CITY

EMMANUEL

FENNEC

GOLF

GLOBE

HAMP

HERITAGE

ICPALLI

KENYA

LAREDO

LINEAL

LONG ISLAND

MARINA

MIN

MOKA

PAL

PARALEL

PUL

ROUND

SIR

TAHITI

TUB

U

VELETTA

WEAVE

WEEKEND

LOUNGE CHAIRS



ALOS
Ref. 72645 | MOQ 10

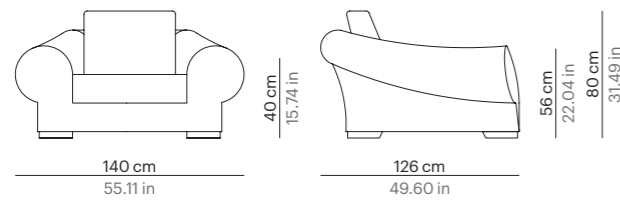

ARC
Ref. 76245 | NO MOQ

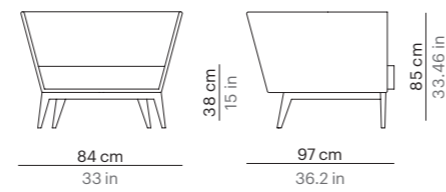

BUBBLE
Ref. 72445 | NO MOQ

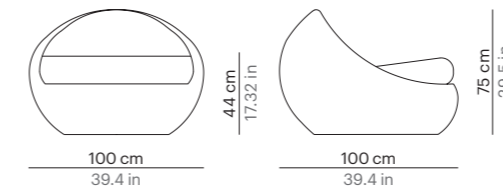

BRUMAS
Ref. 71145 | NO MOQ

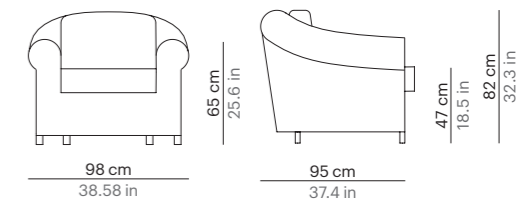

ARENA
Ref. 70045 | NO MOQ

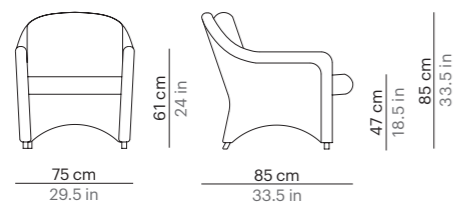

BOX
Ref. 71445 | MOQ 10

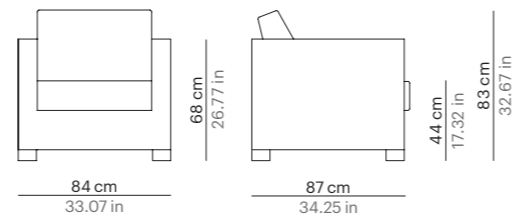

CASABLANCA
Ref. 72745 | MOQ 10

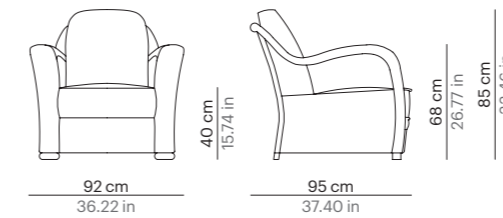

CITY
Ref. 78345 | NO MOQ

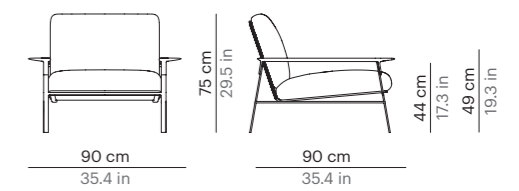

EMMANUEL
Ref. 73245 | MOQ 5

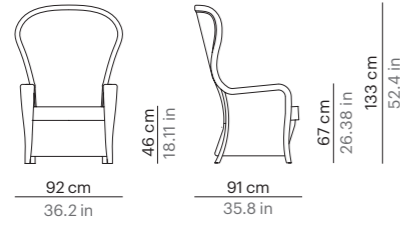

FENNEC
Ref. 74945 | MOQ 10

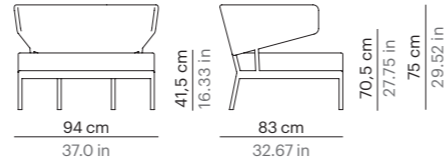

HERITAGE
Ref. 78745 | NO MOQ

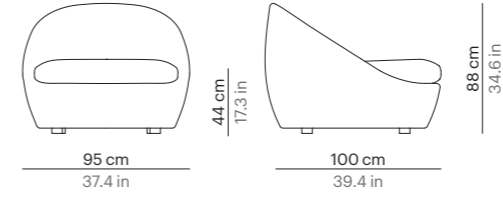

ICPALLI
Ref. 76045 | MOQ 10

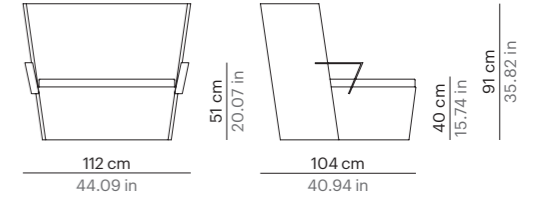

GOLF
Ref. 71545 | MOQ 5

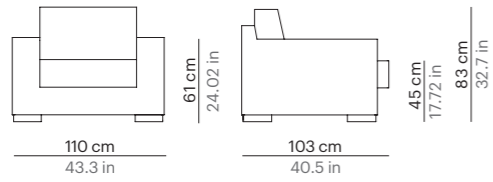

GLOBE
Ref. 71645 | MOQ 10

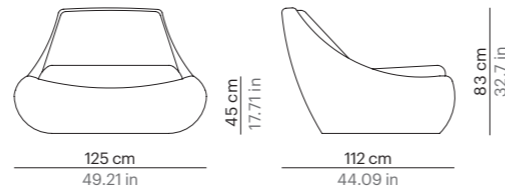

KENYA
Ref. 73445 | MOQ 5

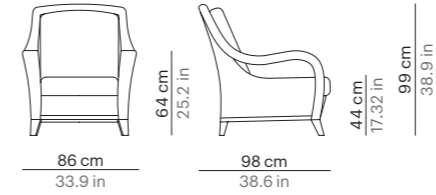

LAREDO
Ref. 72045 | MOQ 10

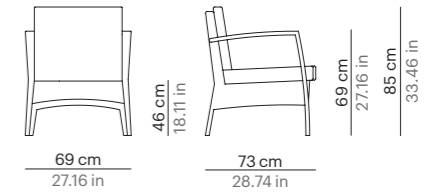

HAMP
Ref. 76745 | NO MOQ

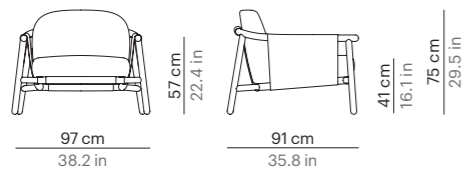

HERITAGE
Ref. 78545 | NO MOQ

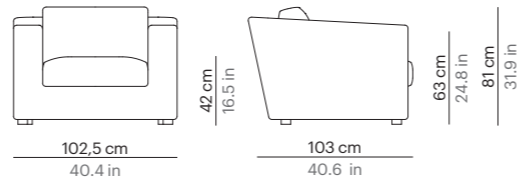

LINEAL
Ref. 76345 | MOQ 5

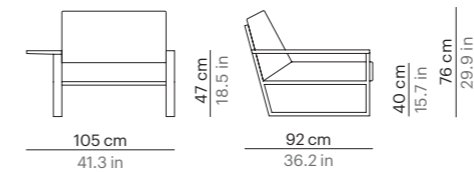

LINEAL
Ref. 76145 | MOQ 10

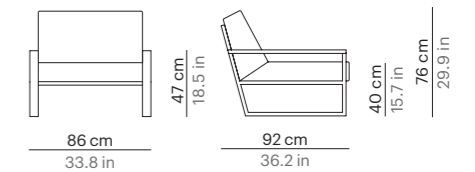



LONG ISLAND
Ref. 77845 | NO MOQ

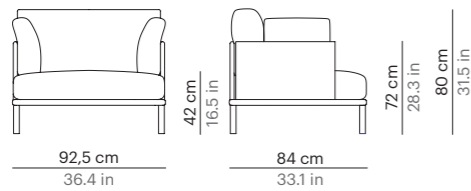

MARINA
Ref. 71045 | MOQ 10

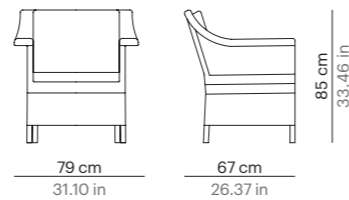

MIN
Ref. 77345 | NO MOQ

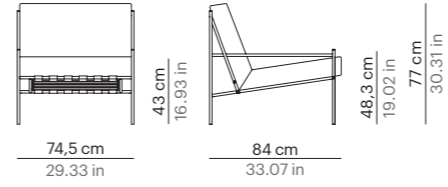

GREEN
Ref. 76845 | MOQ 10

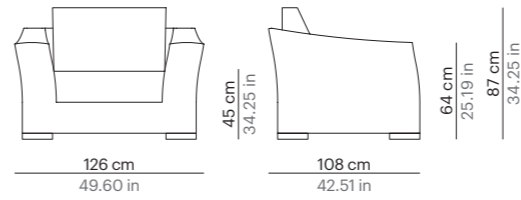

PUL
Ref. 76645 | MOQ 10

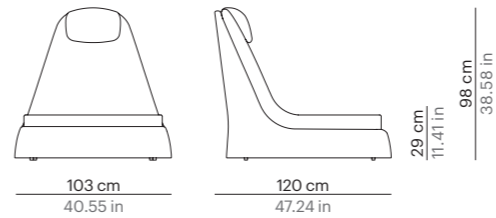

MOKA
Ref. 74045 | MOQ 10

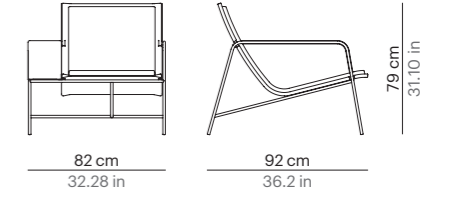

PARALEL
Ref. 77645 | NO MOQ

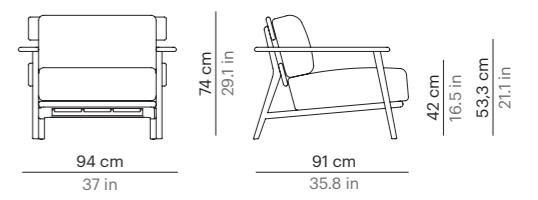

ROUND
Ref. 76545 | MOQ 5

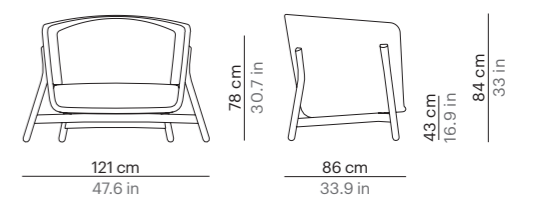

SIR

Ref. 77245 | MOQ 80

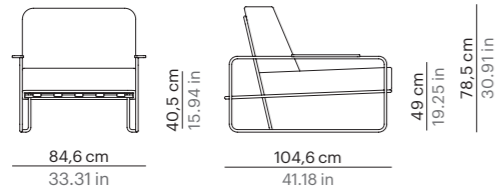
**TAHITI**

Ref. 72096 | MOQ 10

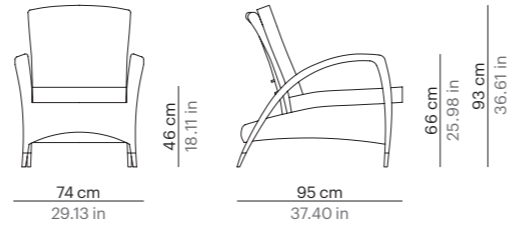
**WEAVE**

Ref. 78145 | NO MOQ

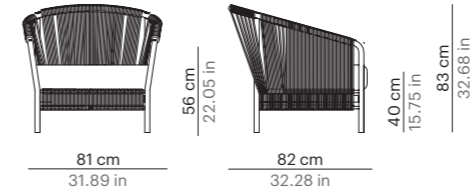
**WEAVE**

Ref. 77198 | NO MOQ

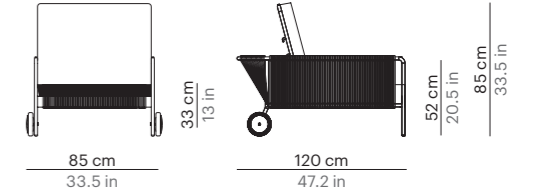
**TUB**

Ref. 74845 | MOQ 50

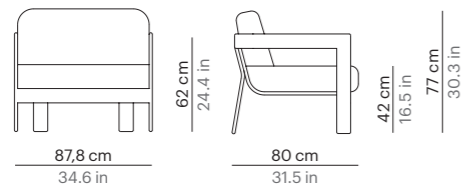
**U**

Ref. 74245 | MOQ 5

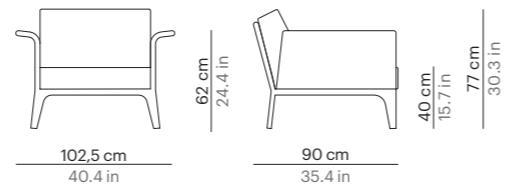
**WEEKEND**

Ref. 73145 | MOQ 80

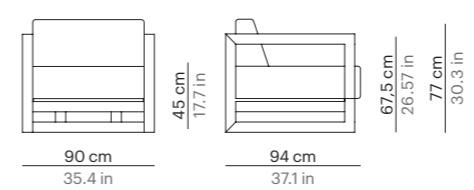
**VELETTA**

Ref. 73645 | MOQ 10

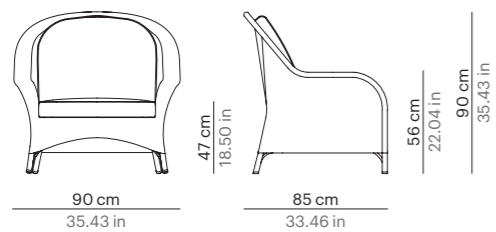
**WEAVE**

Ref. 77145 | MOQ 10

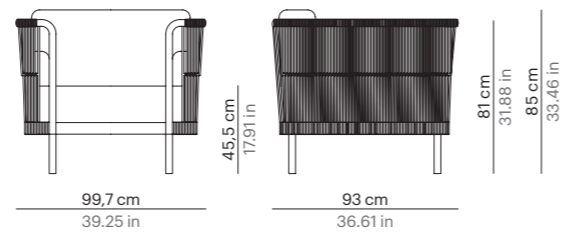

Sofas 2

ARENA

ARC

BOX

BRUMAS

BUBBLE

CASABLANCA

CITY

FENNEC

GOLF

GLOBE

HAMP

HERITAGE

KENYA

LAREDO

LINEAL

LONG ISLAND

MARINA

MIN

PAL

PARALEL

ROUND

TUB

U

VELETTA

WEAVE

WEEKEND

SOFAS 2



ARC

Ref. 76247 | NO MOQ

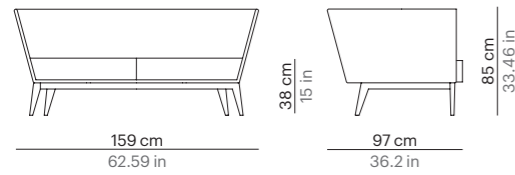

ARENA

Ref. 70047 | NO MOQ

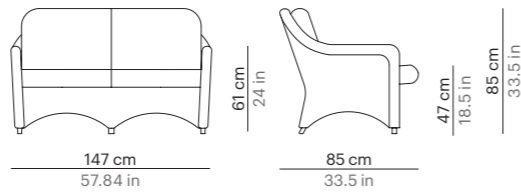

BUBBLE

Ref. 72447 | MOQ 5

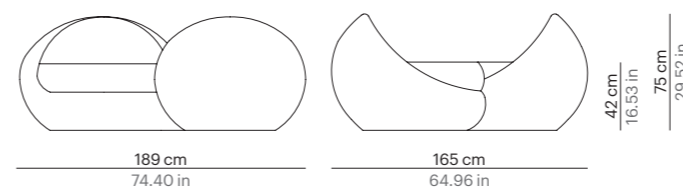

CASABLANCA

Ref. 72747 | MOQ 10

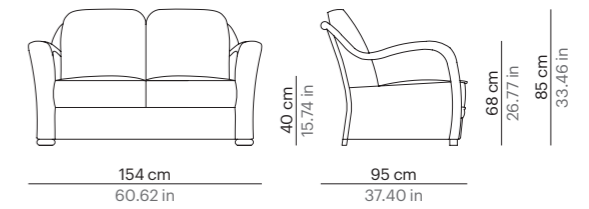

BOX

Ref. 71447 | MOQ 10

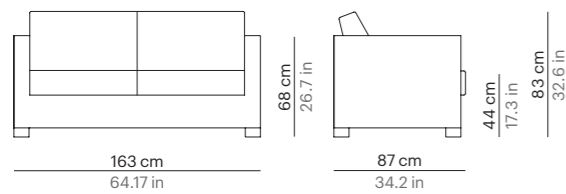

BRUMAS

Ref. 71147 | NO MOQ

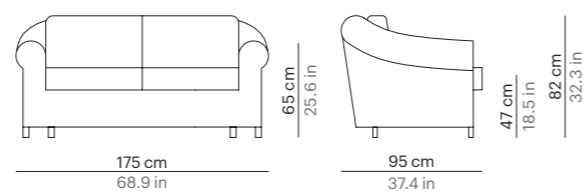

CITY

Ref. 78347 | NO MOQ

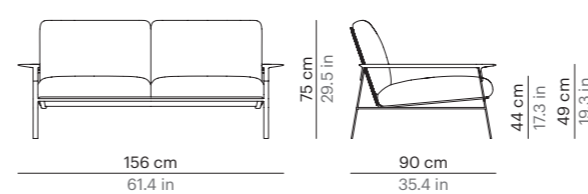

FENNEC

Ref. 74947 | MOQ 10

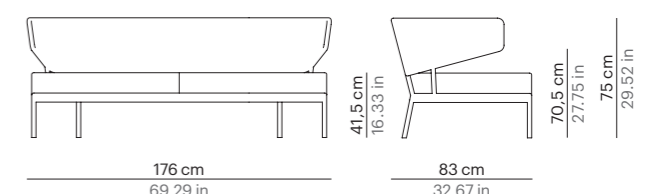

GOLF
Ref. 71547 | MOQ 5

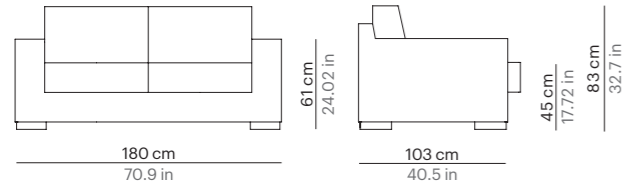

GLOBE
Ref. 71647 | MOQ 10

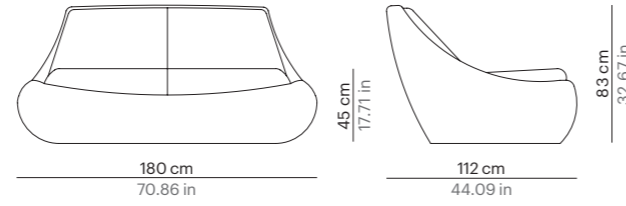

KENYA
Ref. 73447 | MOQ 5

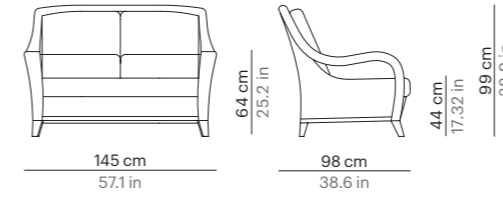

LAREDO
Ref. 72047 | MOQ 10

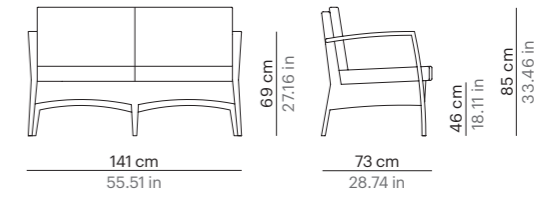

GREEN
Ref. 76847 | MOQ 10

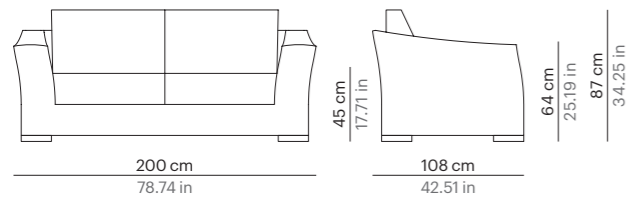

HAMP
Ref. 76747 | NO MOQ

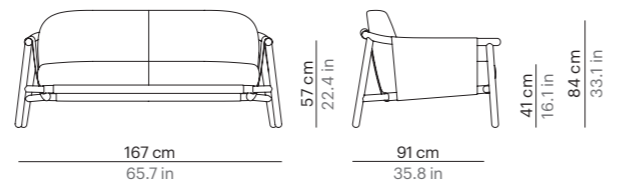

LINEAL
Ref. 76347 | MOQ 5

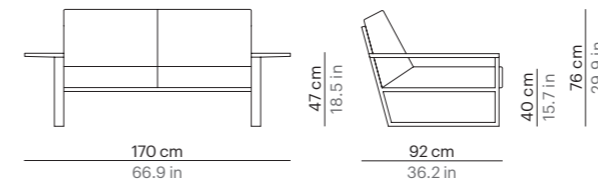

LINEAL
Ref. 76147 | MOQ 10

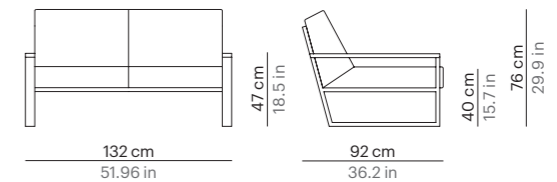

HERITAGE
Ref. 78547 | NO MOQ

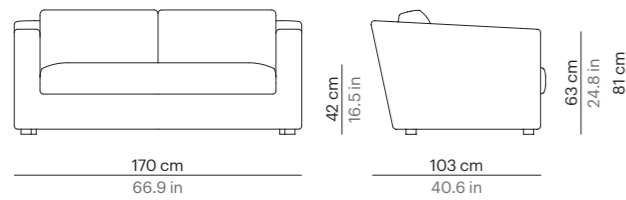

HERITAGE
Ref. 78747 | NO MOQ

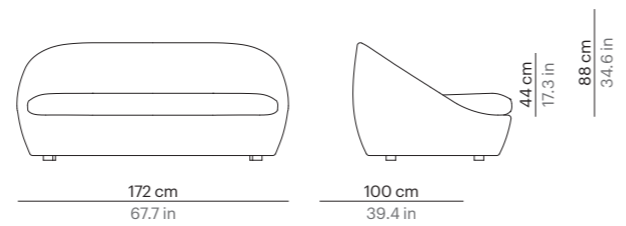

LONG ISLAND
Ref. 77847 | NO MOQ

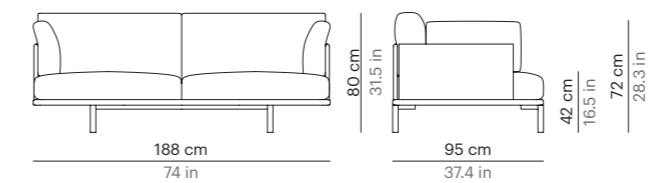

MARINA
Ref. 71047 | MOQ 10

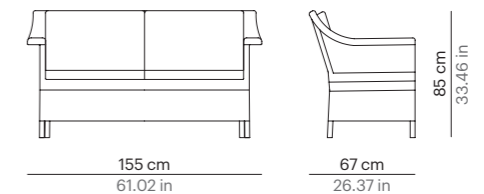

MIN
Ref. 77347 | NO MOQ

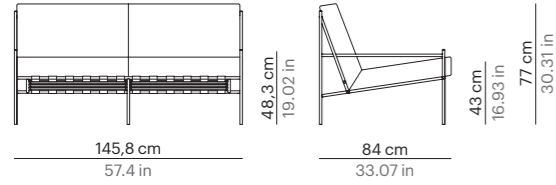

PAL
Ref. 7704912 | NO MOQ

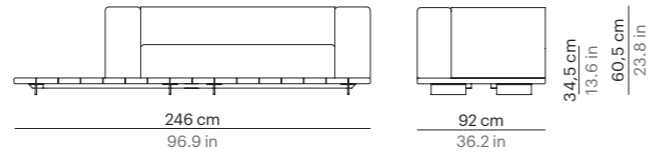

PARALEL
Ref. 77647 | NO MOQ

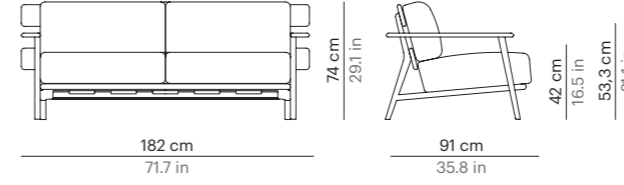

ROUND
Ref. 76547 | MOQ 5

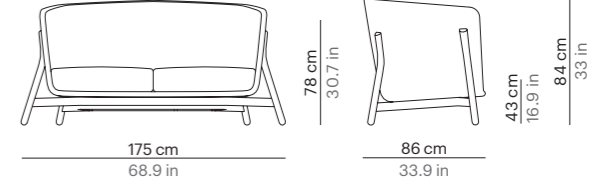

PAL
Ref. 7704700 | NO MOQ

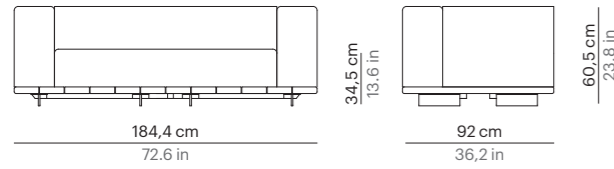

TUB
Ref. 74847 | MOQ 30

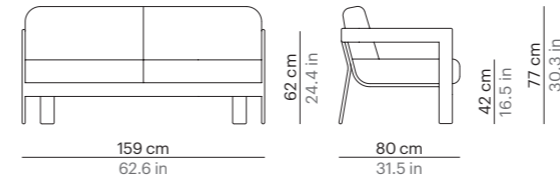

U
Ref. 74247 | MOQ 5

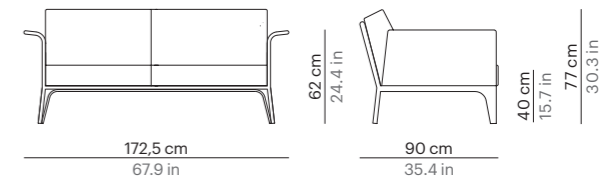

PAL
Ref. 7704911 | NO MOQ

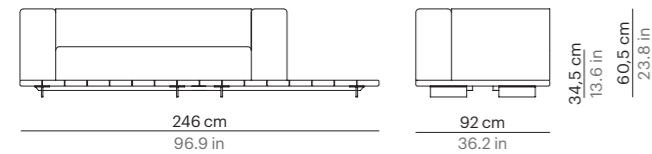

VELETTA
Ref. 73647 | MOQ 10

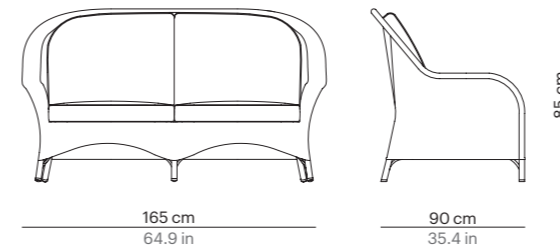

WEAVE
Ref. 78147 | NO MOQ

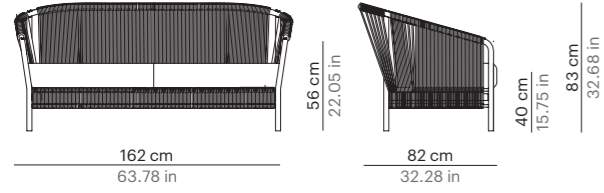

WEAVE
Ref. 77147 | MOQ 10

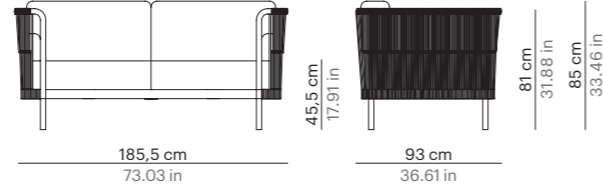

WEAVE
Ref. 77167 | NO MOQ

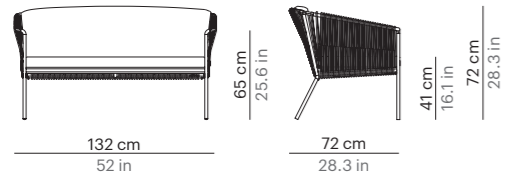

WEEKEND
Ref. 73147 | MOQ 50

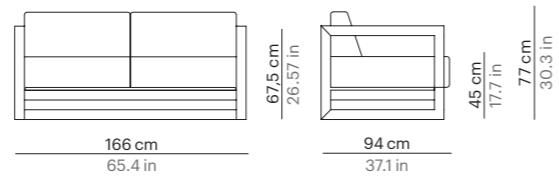

Sofas 3

ALOS

ARC

ARENA

BOX

BRUMAS

CASABLANCA

CITY

FENNEC

GOLF

GLOBE

HERITAGE

KENYA

LAREDO

LINEAL

LONG ISLAND

MARINA

MIN

MOKA

PAL

PARALEL

ROUND

TUB

U

WEAVE

WEEKEND

SOFAS 3



ALOS
Ref. 72649 | MOQ 10

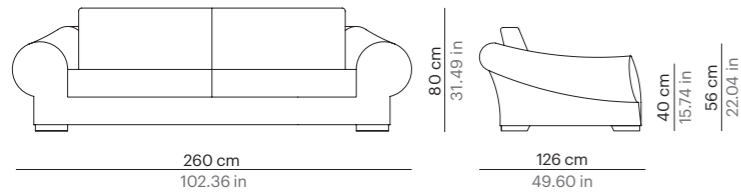

ARC
Ref. 76249 | NO MOQ

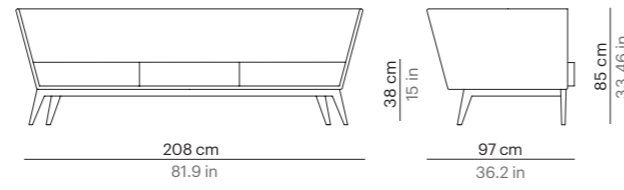

BRUMAS
Ref. 71149 | NO MOQ

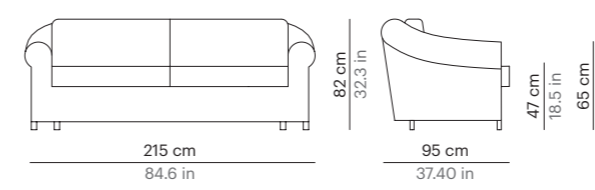

CASABLANCA
Ref. 72749 | MOQ 10

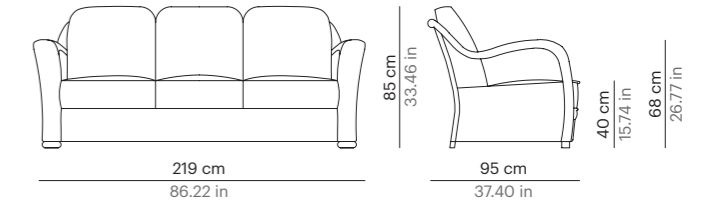

ARENA
Ref. 70049 | NO MOQ

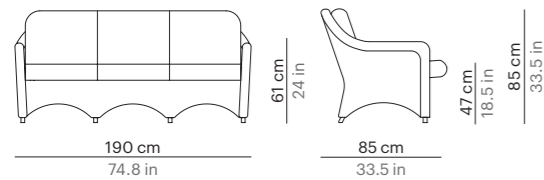

BOX
Ref. 71449 | MOQ 10

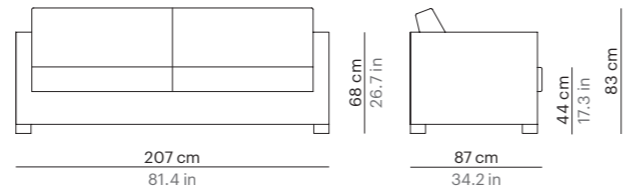

CITY
Ref. 78349 | NO MOQ

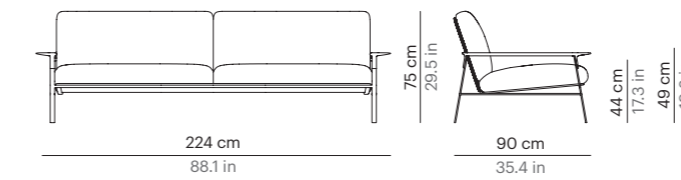

FENNEC
Ref. 74949 | MOQ 10

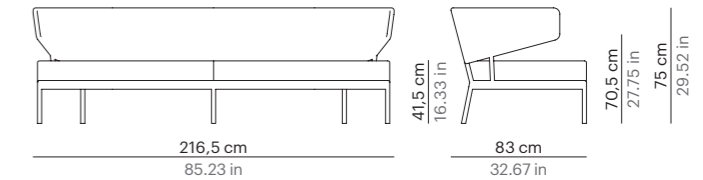

GOLF
Ref. 71549 | MOQ 5

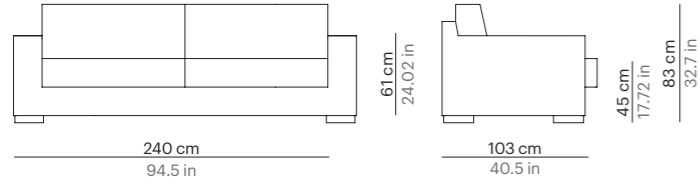

GLOBE
Ref. 71649 | MOQ 10

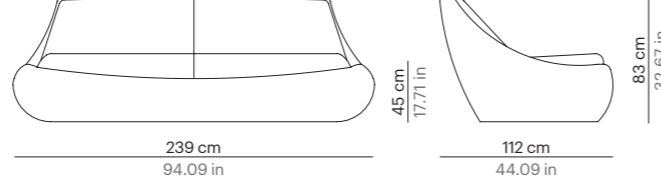

LAREDO
Ref. 72049 | MOQ 10

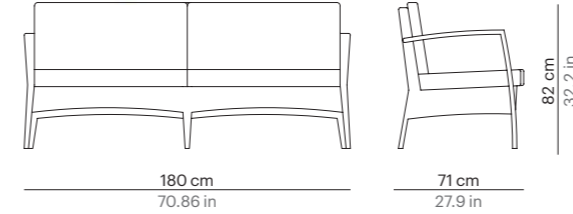

GREEN
Ref. 76849 | MOQ 10

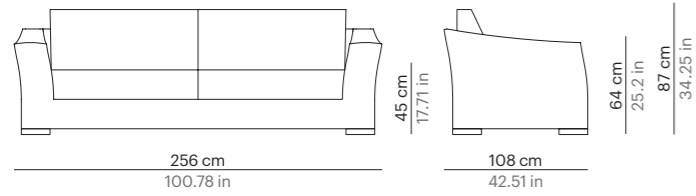

HERITAGE
Ref. 78549 | NO MOQ

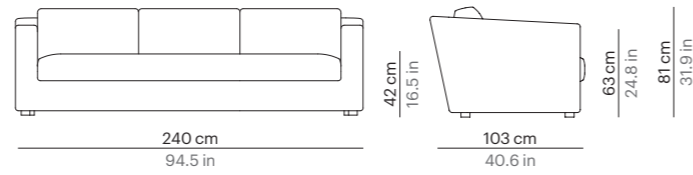

LINEAL
Ref. 76349 | MOQ 5

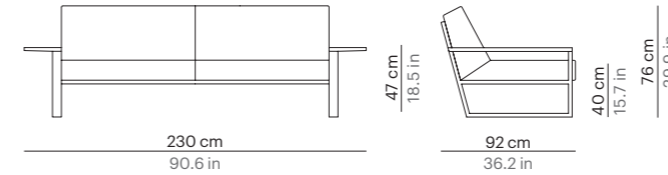

LINEAL
Ref. 76149 | MOQ 10

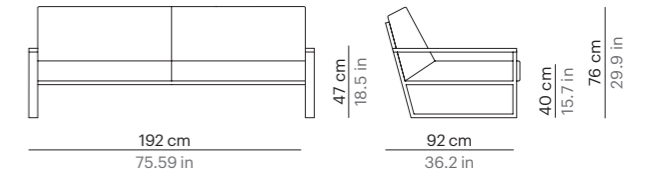

HERITAGE
Ref. 78749 | NO MOQ

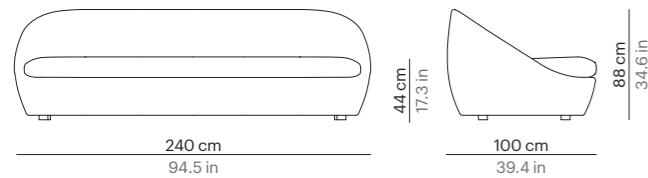

KENYA
Ref. 73449 | MOQ 5

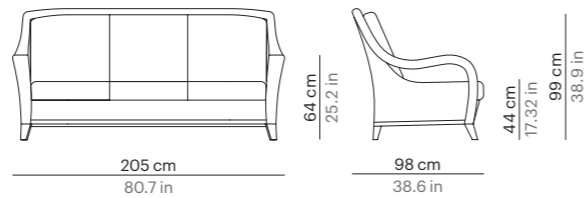

LONG ISLAND
Ref. 77849 | NO MOQ

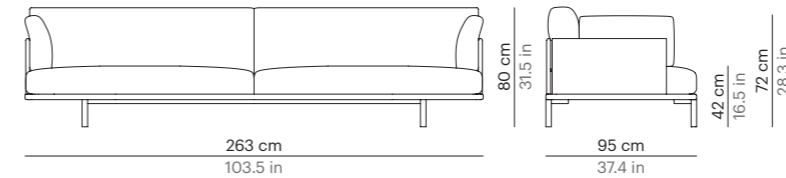

MARINA
Ref. 71049 | MOQ 10

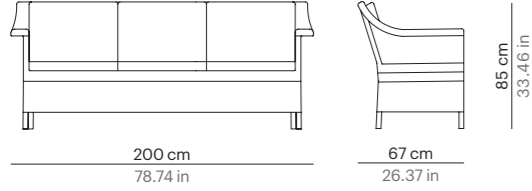

MIN
Ref. 77349 | NO MOQ

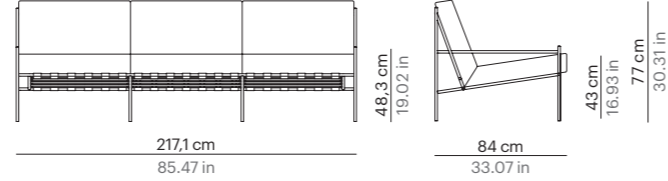

TUB
Ref. 74849 | MOQ 30

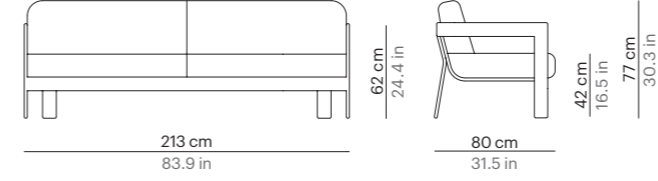

U
Ref. 74249 | MOQ 5

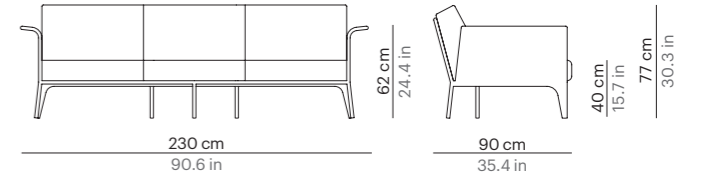

MOKA
Ref. 74049 | MOQ 10

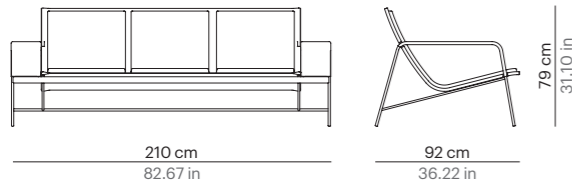

PAL
Ref. 7704900 | NO MOQ

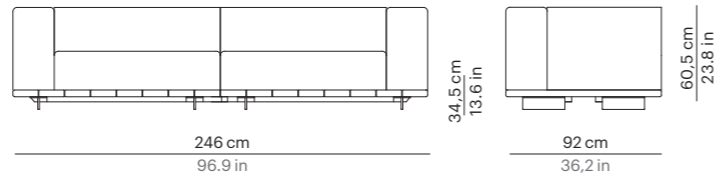

WEAVE
Ref. 77149 | MOQ 10

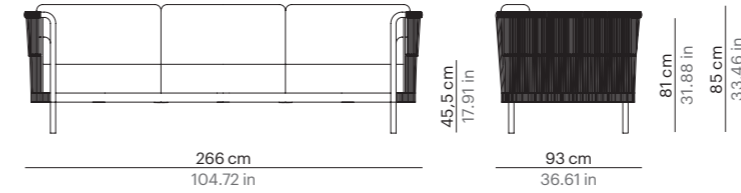

PARALEL
Ref. 77649 | NO MOQ

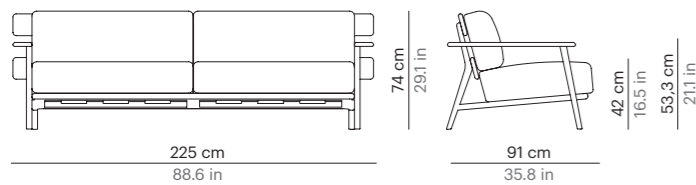

ROUND
Ref. 76549 | MOQ 5

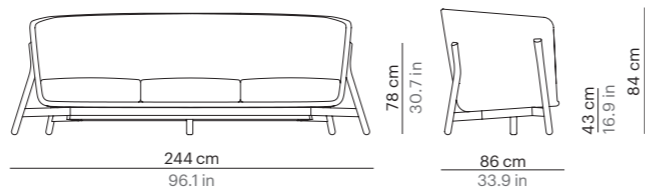

WEAVE
Ref. 78149 | NO MOQ

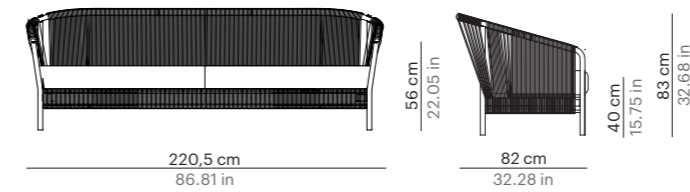

WEEKEND
Ref. 73149 | MOQ 30

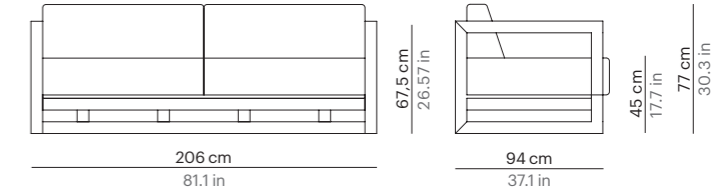

Sectionals

GOLF
HERITAGE
LINEAL
LONG ISLAND
PAL
U
WEAVE

SECTIONALS

GOLF
Ref. 71550 | MOQ 10

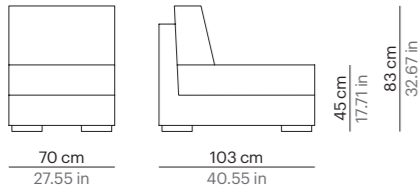

GOLF
Ref. 71551 | MOQ 10

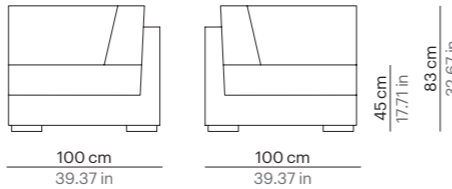

GOLF
Ref. 71542 | MOQ 10

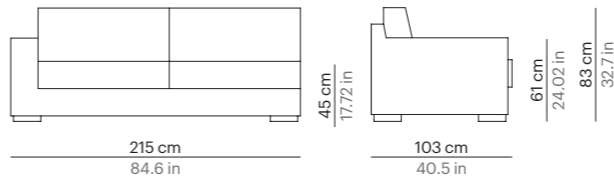

GOLF
Ref. 71543 | MOQ 10

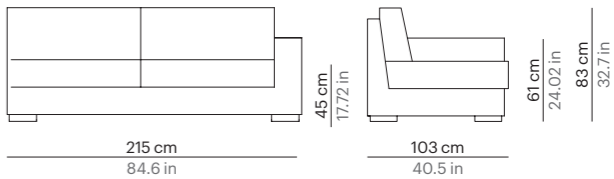

GOLF
Ref. 71544 | MOQ 10

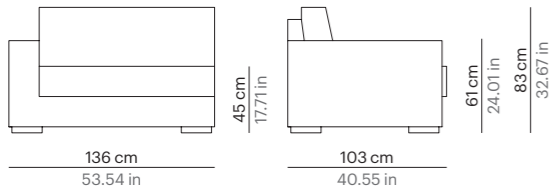

GOLF
Ref. 71546 | MOQ 10

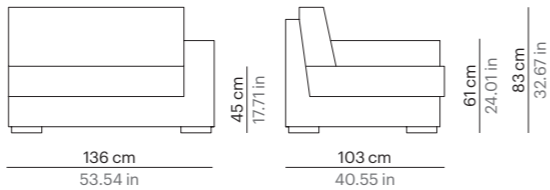

GOLF
Ref. 71541 | MOQ 5

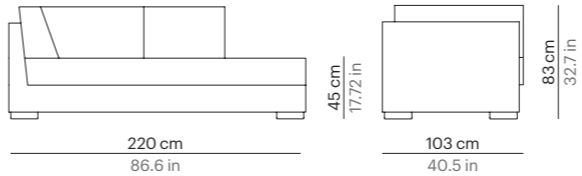

GOLF
Ref. 71540 | MOQ 5

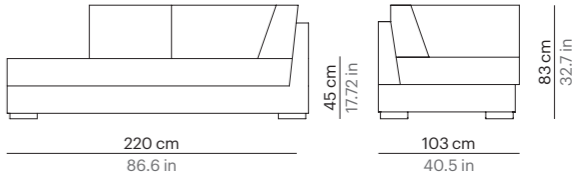

SUGGESTED COMPOSITIONS

GOLF & GREEN COLLECTION

Composition 1



Ud.	Ref.	Descripción Description
1	71542	Sofá Modular 3 Brazo Dcho. Modular Sofa 3 Right Arm
1	71543	Sofá Modular 3 Brazo Izq. Modular Sofa 3 Left Arm
2	72653	Mesa Centro Cuadrada sin Cristal Square Coffee Table without Glass

Composition 2



Ud.	Ref.	Descripción Description
1	71549	Sofá 3 Sofa 3
1	71547	Sofá 2 Sofa 2
1	72653	Mesa Centro Cuadrada sin Cristal Square Coffee Table without Glass
1	72656	Mesa Rincón sin Cristal Corner Table without Glass

Composition 5



Ud.	Ref.	Descripción Description
1	71540	Módulo Rincón Brazo Dcho. Corner Modular Right Arm
1	71541	Módulo Rincón Brazo Izq. Corner Modular Left Arm

Composition 3



Ud.	Ref.	Descripción Description
1	71549	Sofá 3 Sofa 3
2	71545	Sillón Armchair
1	72653	Mesa Centro Cuadrada sin Cristal Square Coffee Table without Glass
2	72656	Mesa Rincón sin Cristal Corner Table without Glass

Composition 4



Ud.	Ref.	Descripción Description
2	71545	Sillón Armchair
2	71552	Puf Ottoman
1	72656	Mesa Rincón sin Cristal Corner Table without Glass

SUGGESTED COMPOSITIONS

HERITAGE COLLECTION

HERITAGE
Ref. 78544 | NO MOQ

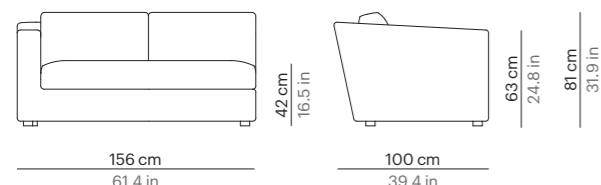

HERITAGE
Ref. 78546 | NO MOQ

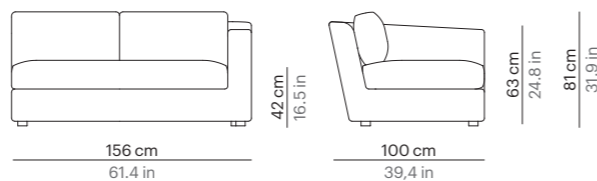

HERITAGE
Ref. 78551 | NO MOQ

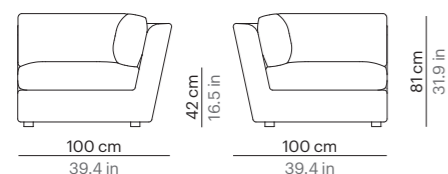

HERITAGE
Ref. 78542 | NO MOQ

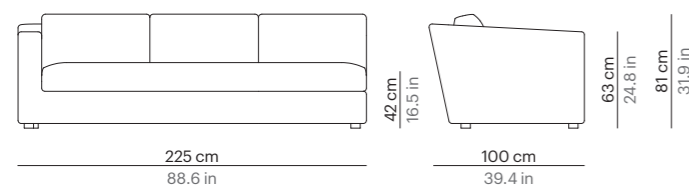

HERITAGE
Ref. 78543 | NO MOQ

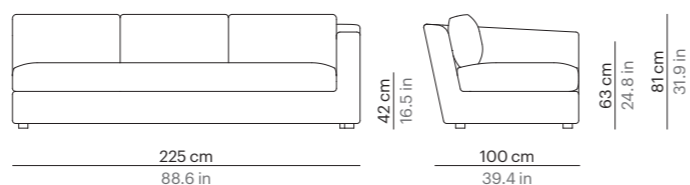

Composition 1



Uds.	Ref.	Descripción	Description
1	78542	Sofá 3 Mod. Brazo Derecho	Right Arm Sectional Sofa 3
1	78551	Rinconera	Corner
1	78546	Sofá 2 Mod. Brazo Izquierdo	Left Arm Sectional Sofa 2
1	78553	Mesa Teca Centro Cuadrada	Teak Square Coffee Table

Composition 2



Uds.	Ref.	Descripción	Description
4	78545	Sillón	Lounge Chair
1	78544	Sofá 2 Mod. Brazo Derecho	Right Arm Sectional Sofa 2
1	78546	Sofá 2 Mod. Brazo Izquierdo	Left Arm Sectional Sofa 2
2	78553	Mesa Teca Centro Cuadrada	Teak Square Coffee Table
2	78556	Mesa Teca Rincón Cuadrada	Teak Square Side Table

Composition 3



Uds.	Ref.	Descripción	Description
1	78542	Sofá 3 Mod. Brazo Derecho	Right Arm Sectional Sofa 3
1	78543	Sofá 3 Mod. Brazo Izquierdo	Left Arm Sectional Sofa 3
2	78553	Mesa Teca Centro Cuadrada	Teak Square Coffee Table

LINEAL
Ref. 76344 | MOQ 10

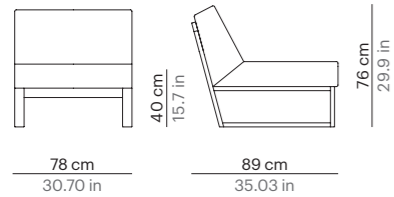

LINEAL
Ref. 76346 | MOQ 10

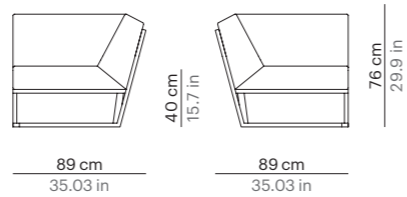

LINEAL
Ref. 76342 | MOQ 10

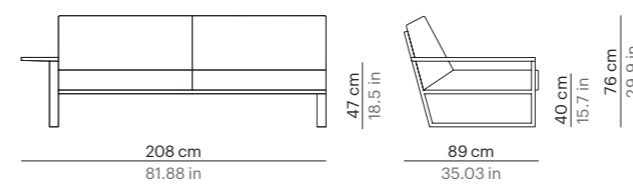

LINEAL
Ref. 76142 | MOQ 10

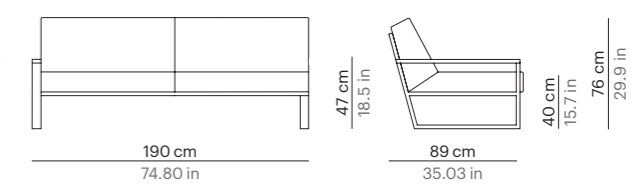

LINEAL
Ref. 76341 | MOQ 10

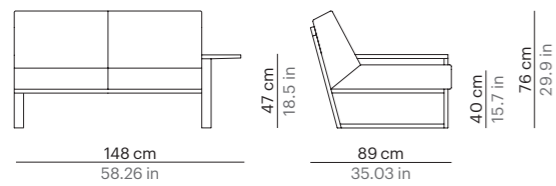

LINEAL
Ref. 76141 | MOQ 10

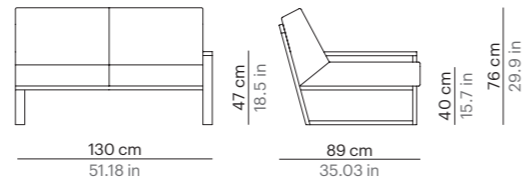

LINEAL
Ref. 76343 | MOQ 10

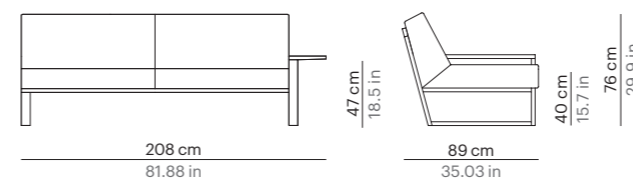

LINEAL
Ref. 76143 | MOQ 10

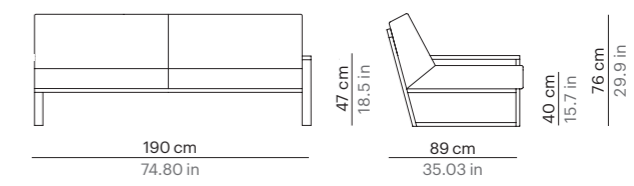

LINEAL
Ref. 76340 | MOQ 10

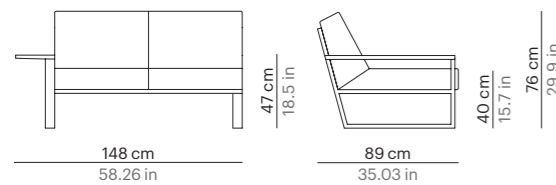

LINEAL
Ref. 76140 | MOQ 10

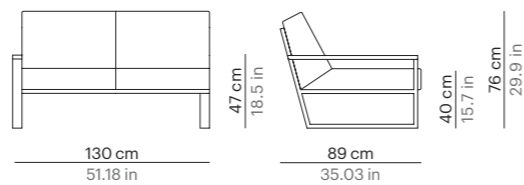

SUGGESTED COMPOSITIONS

LINEAL COLLECTION

Composition 1



Ud.	Ref.	Descripción Description
1	76340	Sofá Modular 2 Brazo Derecho Modular Sofa 2 Right Arm
1	76346	Módulo Rincón Module Corner
1	76343	Sofá Modular 3 Brazo Izquierdo Modular Sofa 3 Left Arm
1	76354	Mesa Centro Rect. Rectangular Coffee Table

Composition 2



Ud.	Ref.	Descripción Description
1	76342	Sofá Modular 3 Brazo Derecho Modular Sofa 3 Right Arm
1	76396	Tumbona Brazo Izquierdo Sun Bed Left Arm
1	76354	Mesa Centro Rectangular Rectangular Coffee Table

Composition 3



Ud.	Ref.	Descripción Description
1	76342	Sofá Modular 3 Brazo Derecho Modular Sofa 3 Right Arm
1	76343	Sofá Modular 3 Brazo Izq. Modular Sofa 3 Left Arm
1	76354	Mesa Centro Rectangular Rectangular Coffee Table

Composition 4



Ud.	Ref.	Descripción Description
1	76340	Sofá Modular 2 Brazo Derecho Modular Sofa 2 Right Arm
1	76341	Sofá Modular 2 Brazo Izq. Modular Sofa 2 Left Arm
1	76354	Mesa Centro Rectangular Rectangular Coffee Table

Composition 5



Ud.	Ref.	Descripción Description
1	76342	Sofá Modular 3 Brazo Dcho. Modular Sofa 3 Right Arm
1	76343	Sofá Modular 3 Brazo Izq Module Sofa 3 Left Arm
2	76346	Módulo Rincón Module Corner
3	76344	Módulo Central Module Center
1	76354	Mesa Centro Rect. Rectangular Coffee Table

Composition 6



Ud.	Ref.	Descripción Description
1	76347	Sofá 2 Sofa 2
1	76349	Sofá 3 Sofa 3
1	76354	Mesa Centro Rectangular Rectangular Coffee Table
1	76356	Mesa Rincón Corner Table

Composition 7



Ud.	Ref.	Descripción Description
1	76349	Sofá 3 Sofa 3
2	76345	Sillón Armchair
1	73654	Mesa Centro Rectangular Rectangular Coffee Table
2	73656	Mesa Rincón Corner Table

Composition 8



Ud.	Ref.	Descripción Description
2	76345	Sillón Armchair
1	76356	Mesa Rincón Corner Table

Composition 9



Ud.	Ref.	Descripción Description
1	76395	Tumbona Brazo Dcho Sun Bed Right Arm
1	76396	Tumbona Brazo Izq Sun Bed Left Arm

LONG ISLAND
Ref. 77844 | NO MOQ

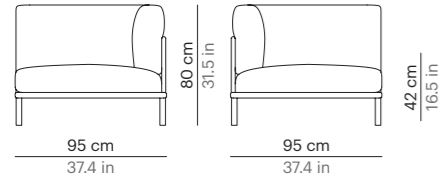

LONG ISLAND
Ref. 77846 | NO MOQ

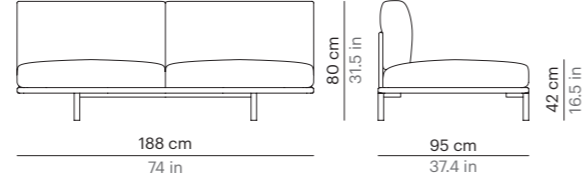

LONG ISLAND
Ref. 77842 | NO MOQ

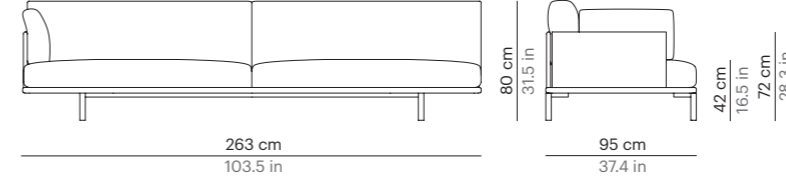

LONG ISLAND
Ref. 77841 | NO MOQ

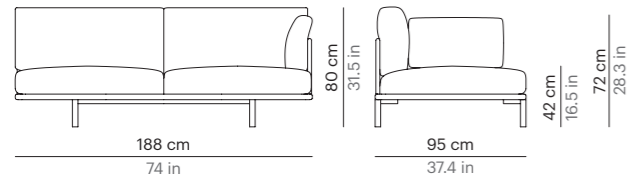

LONG ISLAND
Ref. 77843 | NO MOQ

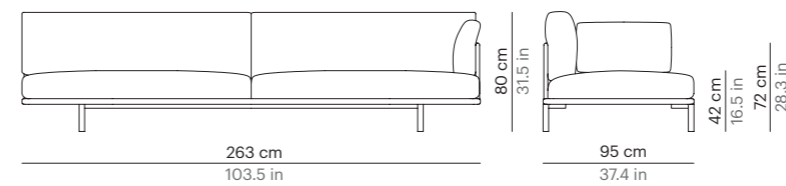

LONG ISLAND
Ref. 77840 | NO MOQ

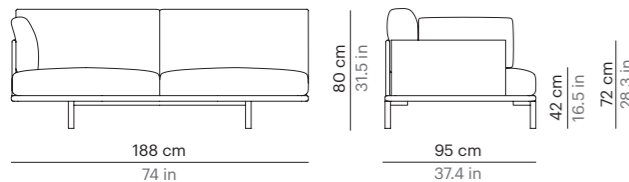

LONG ISLAND
Ref. 77848 | NO MOQ

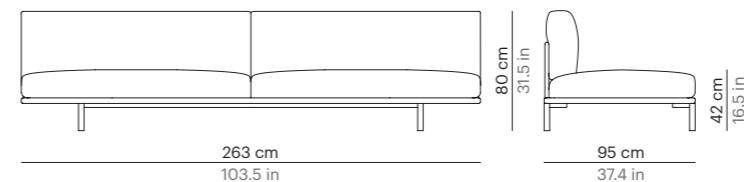

SUGGESTED COMPOSITIONS

LONG ISLAND COLLECTION

Composition 1



Ud.	Ref.	Descripción Description
1	77840	Sofá 2 Modular Brazo Derecho Sofa 2 Modular Right Arm
1	77844	Mod. Rinconera Corner Mod.
1	77843	Sofá 3 Modular Brazo Izquierdo Sofa 3 Modular Left Arm
1	77853	Mesa Centro Cuadrada Square Coffee Table
Peso Weight	204 Kg	449.7 lb
m³	4,39 m³	

Composition 3



Ud.	Ref.	Descripción Description
1	77840	Sofá 2 Modular Brazo Derecho Sofa 2 Modular Right Arm
2	77844	Mod. Rinconera Corner Mod.
1	77848	Sofá 3 Modular Sin Brazos Sofa 3 Modular Without Arms
1	77841	Sofá 2 Modular Brazo Izqdo. Sofa 2 Modular Left Arm
1	77853	Mesa Centro Cuadrada Square Coffee Table
Peso Weight	281,4 Kg	620.4 lb
m³	6,46 m³	

Composition 2



Ud.	Ref.	Descripción Description
1	77897	Chaise Longue Brazo Izquierdo Chaise longue Left Arm
1	77896	Chaise Longue Brazo Derecho Chaise longue Right Arm
Peso Weight	97,6 Kg	215.2 lb
m³	2,7 m³	

Composition 4



Ud.	Ref.	Descripción Description
1	77842	Sofá 3 Modular Brazo Derecho Sofa 3 Modular Right Arm
1	77897	Chaise Longue Brazo Izquierdo Chaise longue Left Arm
1	77854	Mesa Centro Rectangular Rectangular Coffee Table
Peso Weight	169,5 Kg	373.7 lb
m³	3,69 m³	

Composition 5



Ud.	Ref.	Descripción Description
1	77840	Sofá 2 Modular Brazo Derecho Sofa 2 Modular Right Arm
1	77841	Sofá 2 Modular Brazo Izqdo. Sofa 2 Modular Left Arm
2	77853	Mesa Centro Cuadrada Square Coffee Table
Peso Weight	186,4 Kg	410.9 lb
m³	3,62 m³	

Composition 7



Ud.	Ref.	Descripción Description
1	77843	Sofá 3 Modular Brazo Izq. Sofa 3 Modular Left Arm
1	77844	Módulo Rinconera Corner Modular
1	77842	Sofá 3 Mod. Brazo Dcho. Sofa 3 Modular Right Arm
1	77853	Mesa Centro Cuadrada Square Coffee Table
Peso Weight	235 Kg	518.1 lb
m³	4,9 m³	

Composition 9



Ud.	Ref.	Descripción Description
1	77849	Sofá 3 Sofa 3
1	77847	Sofá 2 Sofa 2
1	77856	Mesa Rincón Cuadrada Square Side Table
1	77853	Mesa Centro Cuadrada Square Coffee Table
Peso Weight	203,4 Kg	448.4 lb
m³	4,07 m³	

Composition 6



Ud.	Ref.	Descripción Description
1	77843	Sofá 3 Modular Brazo Izquierdo. Sofa 3 Modular Left Arm
1	77842	Sofá 3 Modular Brazo Derecho Sofa 3 Modular Right Arm
2	77853	Mesa Centro Cuadrada Square Coffee Table
Peso Weight	248,4 Kg	547.6 lb
m³	4,64 m³	

Composition 8



Ud.	Ref.	Descripción Description
1	77849	Sofá 3 Sofa 3
2	77845	Sillón Lounge Chair
2	77856	Mesa Rincón Cuadrada Square Side Table
1	77854	Mesa Centro Rectangular Rectangular Coffee Table
Peso Weight	230,3 Kg	507.7 lb
m³	4,41 m³	

PAL
Ref. 7704502 | NO MOQ

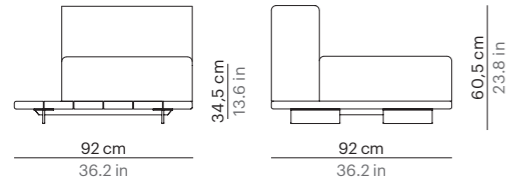

PAL
Ref. 7704503 | NO MOQ

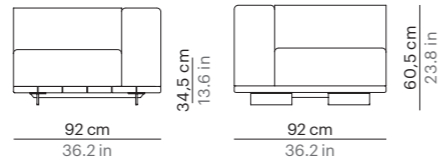

PAL
Ref. 7704706 | NO MOQ

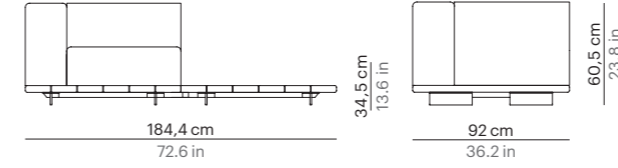

PAL
Ref. 7704701 | NO MOQ

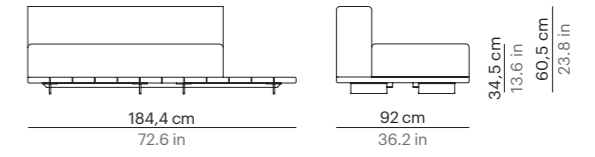

PAL
Ref. 7704501 | NO MOQ

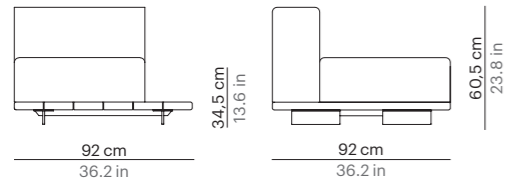

PAL
Ref. 7704504 | NO MOQ

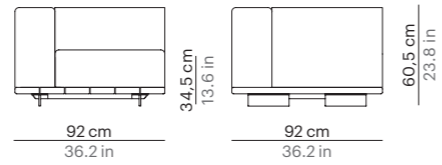

PAL
Ref. 7704709 | NO MOQ

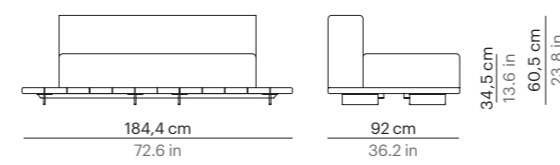

PAL
Ref. 7704500 | NO MOQ

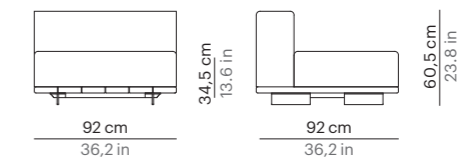

PAL
Ref. 7704705 | NO MOQ

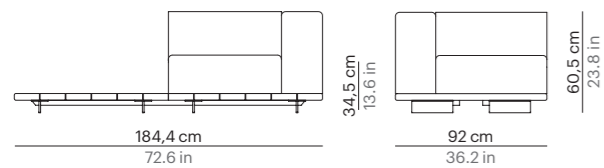

PAL
Ref. 7704702 | NO MOQ

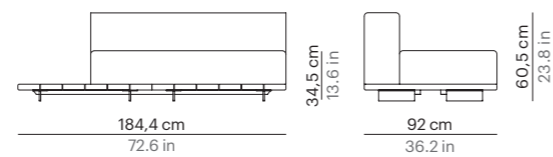

PAL
Ref. 7704708 | NO MOQ

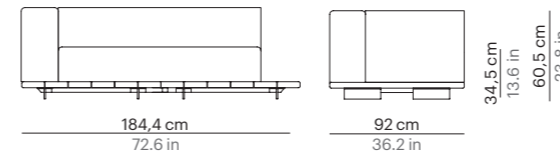

PAL
Ref. 7704711 | NO MOQ

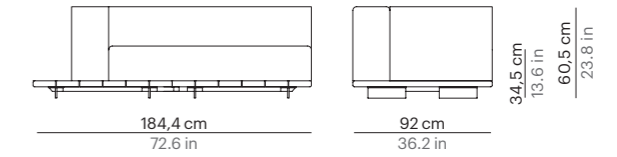

PAL
Ref. 7704703 | NO MOQ

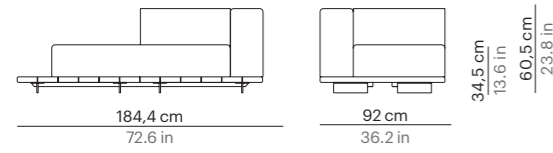

PAL
Ref. 7704710 | NO MOQ

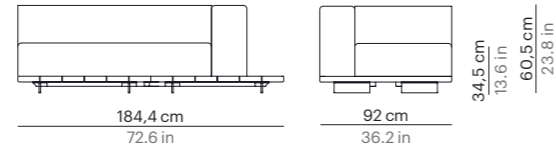

PAL
Ref. 7704902 | NO MOQ

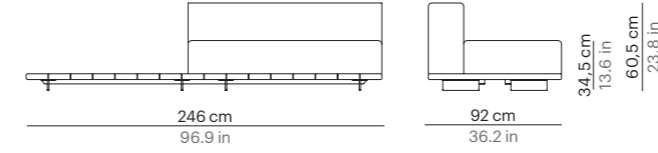

PAL
Ref. 7704913 | NO MOQ

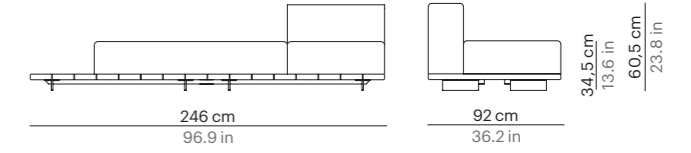

PAL
Ref. 7704704 | NO MOQ

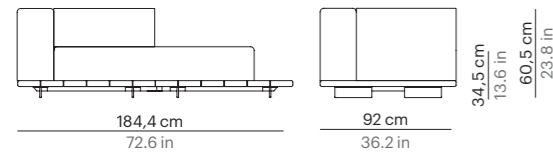

PAL
Ref. 7704901 | NO MOQ

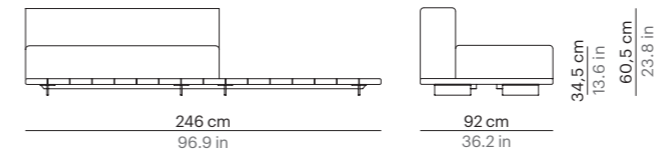

PAL
Ref. 7704905 | NO MOQ

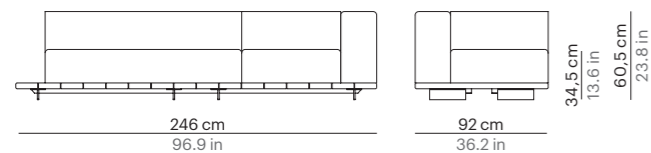

PAL
Ref. 7704707 | NO MOQ

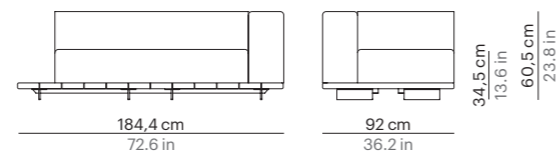

PAL
Ref. 7704903 | NO MOQ

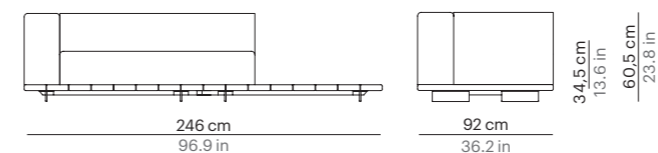

PAL
Ref. 7704914 | NO MOQ

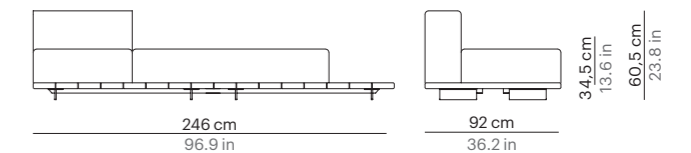

PAL
Ref. 7704904 | NO MOQ

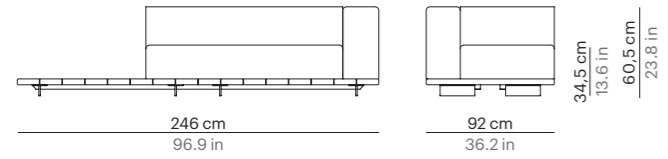

PAL
Ref. 7704907 | NO MOQ

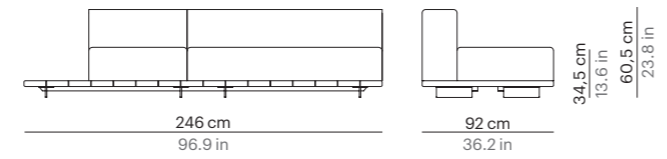

PAL
Ref. 7704910 | NO MOQ

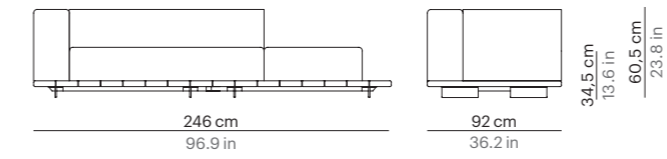

PAL
Ref. 7704917 | NO MOQ

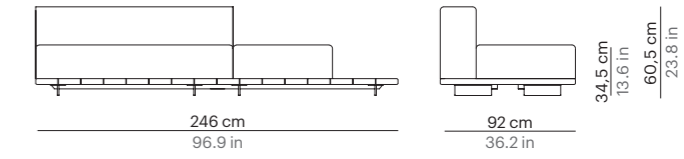

PAL
Ref. 7704909 | NO MOQ

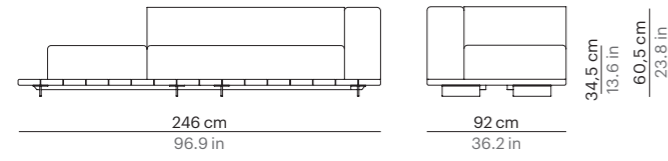

PAL
Ref. 7704916 | NO MOQ

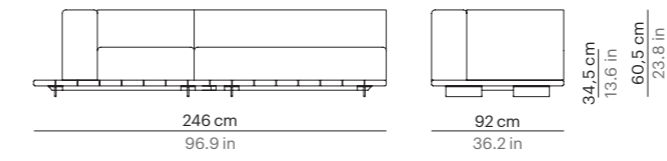

PAL
Ref. 7704908 | NO MOQ

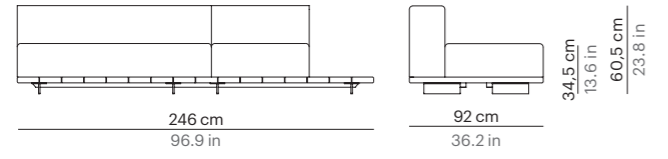

PAL
Ref. 7704906 | NO MOQ

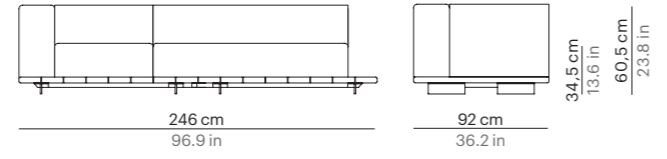

PAL
Ref. 7704918 | NO MOQ

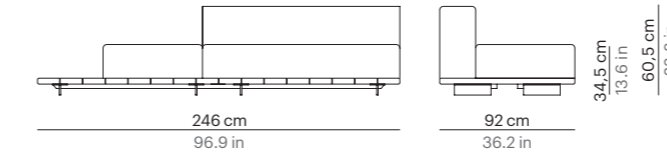

PAL
Ref. 7704915 | NO MOQ

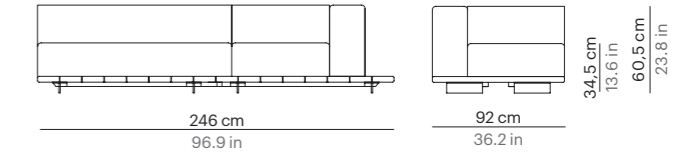

SUGGESTED COMPOSITIONS

PAL COLLECTION

Composition 1



Ud.	Ref.	Descripción Description
1	7704708	Base 184 x 92 + Asiento Doble + Resp. Doble + Brazo Dcho. Base 184 x 92 + Double Seat & Back + Right Arm
1	7704905	Base 246 x 92 + Asiento y Resp. Doble + Asiento y Resp. Single + Brazo Izq. Base 246 x 92 + Double Seat & Back + Single Seat & Back + Left Arm
1	77053	Mesa Tapa Teca sin Cristal Teak Top Table without Glass

Composition 3



Ud.	Ref.	Descripción Description
1	7704907	Base 246 x 92 + Asiento y Resp. Doble + Asiento y Resp. Single Izq. Base 246 x 92 + Left Double Seat & Back + Single Seat & Back
1	7704904	Base 246x92 + Asiento Doble + Resp. Doble + Brazo Izq. Base 246 x 92 + Double Back + Left Arm
1	7704708	Base 184 x 92 + Asiento Doble + Resp. Doble + Brazo Dcho. Base 184 x 92 + Double Seat & Back + Right Arm
1	77055	Mesa tapa teca sin cristal Teak Top Table without Glass
2	77056	Mesa tapa teca sin cristal Teak Top Table without Glass

Composition 2



Ud.	Ref.	Descripción Description
1	7704504	Base 92 x 92 + Asiento Individual + Resp. Single + Brazo Dcho. Base 92 x 92 + Single Seat & Back + Right Arm
1	7704906	Base 246 x 92 + Asiento y Resp. Doble + Asiento y Resp. Single + Brazo Dcho. Base 246 x 92 + Double Seat & Back + Single Seat & Back + Right Arm
1	7704503	Base 92 x 92 + Asiento Individual + Resp. Single + Brazo Izq. Base 92 x 92 + Single Seat & Back + Left Arm
1	77051	Mesa Tapa Teca sin Cristal Teak Top Table without Glass
1	77055	Mesa Tapa Teca sin Cristal Teak Top Table without Glass
1	77056	Mesa Tapa Teca sin Cristal Teak top Table without Glass

Composition 4



Ud.	Ref.	Descripción Description
1	7704708	Base 184 x 92 + Asiento Doble + Resp. Doble + Brazo Dcho. Base 184 x 92 + Double Seat & Back + Right Arm
1	7704501	Base 92 x 92 + Asiento Single + Resp. Single Dcho. Base 92 x 92 + Right Single & Back
1	77050	Mesa Tapa Teca sin Cristal Teak Top Table Without Glass

Composition 5



Ud.	Ref.	Descripción Description
1	7709505	Base 185 x 185 + 2 Asiento Doble + 2 Respaldo Single Vis a Vis Base 185 x 185 + 2 Vis a Vis Double Seat + Single Back

Composition 7



Ud.	Ref.	Descripción Description
1	7704906	Base 246 x 92 + Asiento y Resp. Doble + Asiento y Resp. Single + Brazo Dcho. Base 246 x 92 + Double Seat & Back + Single Seat & Back + Right Arm
1	7704905	Base 246 x 92 + Asiento y Resp. Doble + Asiento y Resp. Single + Brazo Izq. Base 246 x 92 + Double Seat & Back + Single Seat & Back + Left Arm
1	77052	Mesa Tapa Teca sin Cristal Teak Top Table without Glass
2	77050	Mesa Tapa Teca sin Cristal Teak Top Table without Glass

Composition 9

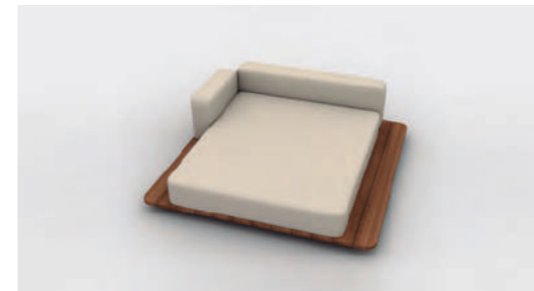

Ud.	Ref.	Descripción Description
1	7709504	Base 185 x 185 + Asiento Tumbona + Resp. Doble + Brazo Dcho. Base 185 x 185 + Sunbed Seat + Double Back + Right Arm

Composition 6



Ud.	Ref.	Descripción Description
1	7709506	Base 185 x 185 + 2 asiento doble + 2 respaldo single paralelos Base 185 x 185 + 2 parallel double seat + 2 single back

Composition 8



Ud.	Ref.	Descripción Description
1	7704902	Base 246 x 92 + Asiento Doble + Resp. Doble Izq. Base 246 x 92 + Left Double Seat & Back
1	7704903	Base 246 x 92 + Asiento Doble + Resp. Doble + Brazo Dcho. Base 246 x 92 + Double Seat & Back + Right Arm
1	7704909	Base 246 x 92 + Asiento y Resp. Doble + Asiento Single + Brazo Izq. Base 246 x 92 + Double Seat and Back + Single Seat + Left Arm
1	7704701	Base 184 x 92 + Asiento Doble + Resp. Doble Dcha. Base 184 x 92 + Right Double Seat & Back
1	77053	Besa Tapa Teca sin Cristal Teak Top Table without Glass
1	77054	Mesa Tapa Teca sin Cristal Teak Top Table without Glass

U
Ref. 74250 | MOQ 5

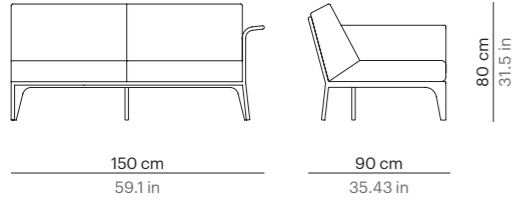

U
Ref. 74248 | MOQ 5

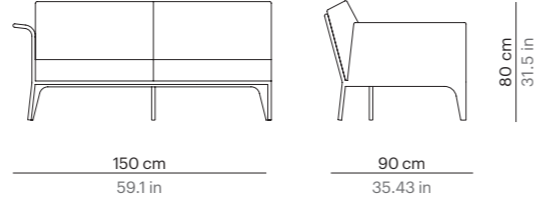

U
Ref. 74243 | MOQ 5

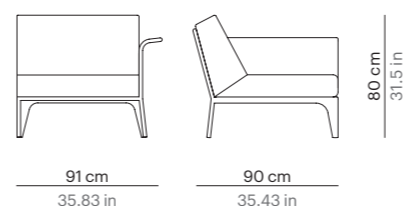

U
Ref. 74242 | MOQ 5

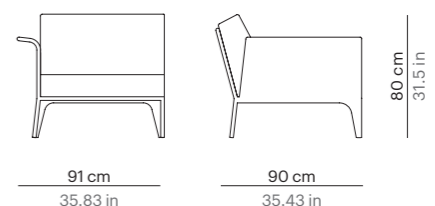

U
Ref. 74259 | MOQ 5

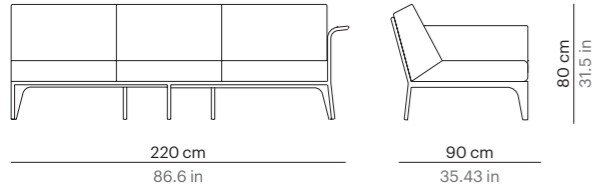

U
Ref. 74251 | MOQ 5

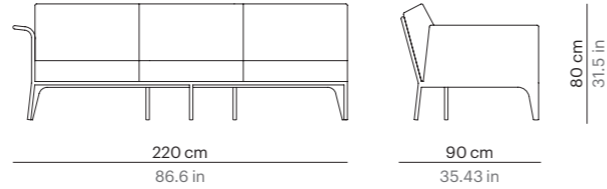

U
Ref. 74241 | MOQ 5

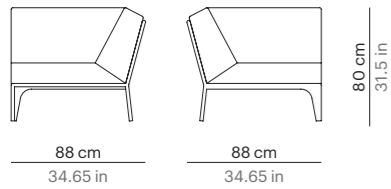

U
Ref. 74244 | MOQ 5

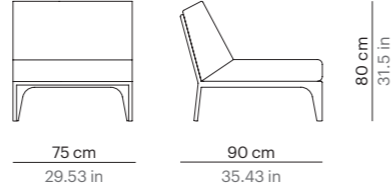

SUGGESTED COMPOSITIONS

U COLLECTION

Composition 1



Ud.	Ref.	Descripción Description
1	74248	Sofá 2 Mod. Dcho. Mod. Sofa 2 Right
1	74241	Módulo Rinconera Corner Modular
1	74259	Sofá 3 Mod. Izq. Mod. Sofa 3 Left
1	74254	Mesa Centro 120 x 63 Coffee Table

Composition 2



Ud.	Ref.	Descripción Description
1	74251	Sofá 3 Mod. Dcho. Mod. Sofa 3 Right
1	74297	Tumbona Brazo Izq. Sunbed Left Arm
1	74253	Mesa Centro 82 x 82 Coffee Table

Composition 3



Ud.	Ref.	Descripción Description
1	74248	Sofá 2 Mod. Dcho. Mod. Sofa 2 Right
1	74250	Sofá 2 Mod. Izq. Mod. Sofa 2 Left
1	74254	Mesa Centro 120 x 63 Coffee Table

Composition 4



Ud.	Ref.	Descripción Description
1	74251	Sofá 3 Mod. Dcho. Mod. Sofa 3 Right
1	74259	Sofá 3 Mod. Izq. Mod. Sofa 3 Left
1	74253	Mesa Centro 82 x 82 Coffee Table

Composition 5



Ud.	Ref.	Descripción Description
1	74248	Sofá 2 Mod. Dcho. Mod. Sofa 2 Right
2	74241	Módulo Rinconera Corner Modular
3	74244	Módulo Centro Center Mod.
1	74250	Sofá 2 Mod. Izq. Mod. Sofa 2 Left
1	74253	Mesa Centro 82 x 82 Coffee Table

Composition 6



Ud.	Ref.	Descripción Description
1	74249	Sofá 3 3 Seater Sofa
1	74247	Sofá 2 2 Seater Sofa
1	74253	Mesa Centro 82 x 82 Coffee Table
1	74258	Mesa Auxiliar Ø 57 Side Table

Composition 7



Ud.	Ref.	Descripción Description
2	74245	Sillón Armchair
1	74249	Sofá 3 3 Seater Sofa
1	74254	Mesa Centro 120 x 63 Coffee Table
2	74258	Mesa Auxiliar Ø 57 Side Table

Composition 8



Ud.	Ref.	Descripción Description
2	74245	Sillón Armchair
2	74252	Puf
1	74258	Mesa Auxiliar Ø 57 Side Table

Composition 9



Ud.	Ref.	Descripción Description
1	74296	Tumbona Brazo Dcho. Sunbed Right Arm
1	74297	Tumbona Brazo Izq. Sunbed Left Arm

WEAVE

Ref. 77144 | MOQ 10

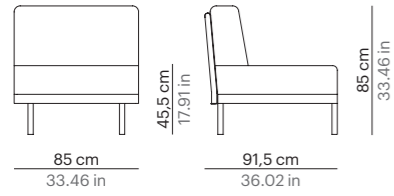

WEAVE

Ref. 77151 | MOQ 10

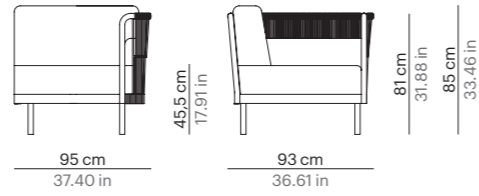

WEAVE

Ref. 77148 | MOQ 10

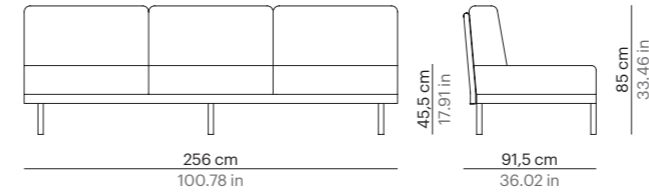

WEAVE

Ref. 77150 | MOQ 10

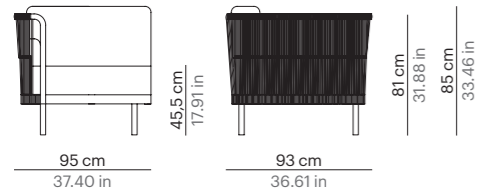

WEAVE

Ref. 77140 | MOQ 10

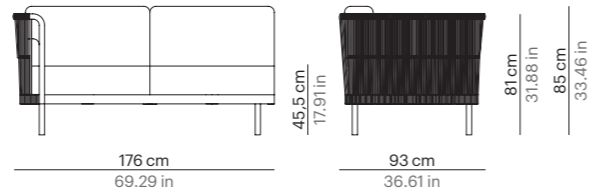

WEAVE

Ref. 77142 | MOQ 10

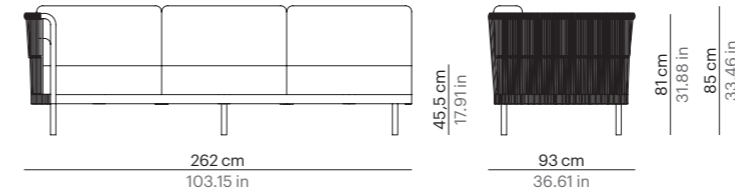

WEAVE

Ref. 77146 | MOQ 10

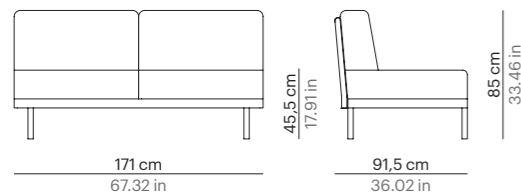

WEAVE

Ref. 77141 | MOQ 10

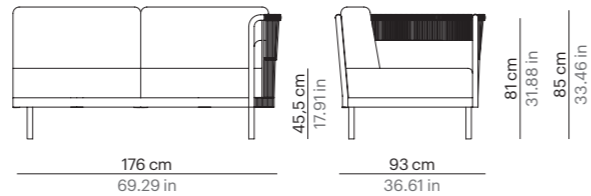

WEAVE

Ref. 77143 | MOQ 10

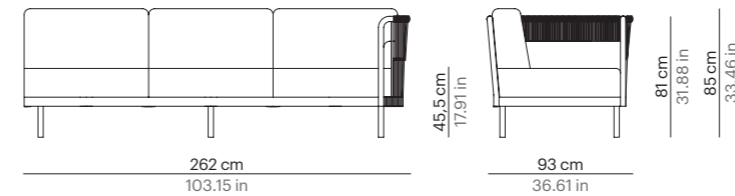

SUGGESTED COMPOSITIONS

WEAVE COLLECTION

Composition 1



Ud.	Ref.	Descripción Description
1	77140	Sofá 2 Modulo Dcho Module Sofa 2 Right
1	77197	Tumbona Brazo Izq. Sun Bed Left Arm
1	77154	Mesa Centro Rectangular Rectangular Coffee Table

Composition 2



Ud.	Ref.	Descripción Description
1	77149	Sofá 3 Sofa 3
1	77147	Sofá 2 Sofa 2
1	77154	Mesa Centro Rectangular Rectangular Coffee Table
1	77156	Mesa Rincón Corner Table

Composition 5



Ud.	Ref.	Descripción Description
1	77140	Módulo Sofá 2 Brazo Dcho Module Sofa 2 Right Arm
1	77141	Módulo Sofá 2 Brazo Izq Module Sofa 2 Left Arm
1	77153	Mesa Centro Cuadrada Square Coffee Table
1	77156	Mesa Rincón Corner Table

Composition 6



Ud.	Ref.	Descripción Description
1	77142	Módulo Sofá 3 Brazo Dcho Module Sofa 3 Right Arm
1	77197	Tumbona Brazo Izq Sun Bed Left Arm
1	77154	Mesa Centro Rectangular Rectangular Coffee Table

Composition 3



Ud.	Ref.	Descripción Description
1	77149	Sofá 3 Sofa 3
2	77145	Sillón Armchair
1	77154	Mesa Centro Rectangular Rectangular Coffee Table
2	77156	Mesa Rincón Corner Table

Composition 4



Ud.	Ref.	Descripción Description
1	77142	Módulo Sofá 3 Brazo Dcho Module Sofa 3 Right Arm
1	77143	Módulo Sofá 3 Brazo Izq Module Sofa 3 Left Arm
2	77153	Mesa Centro Cuadrada Square Coffee Table
1	77156	Mesa Rincón Corner Table

Composition 7



Ud.	Ref.	Descripción Description
2	77150	Módulo Brazo Dcho Module Right Arm
2	77156	Mesa Rincón Corner Table

Composition 8



Ud.	Ref.	Descripción Description
1	77196	Tumbona Brazo Dcho Sun Bed Right Arm
1	77197	Tumbona Brazo Izq Sun Bed Left Arm

PROJECTS

NORIDA BEACH HOTEL

GREECE
WEAVE COLLECTION

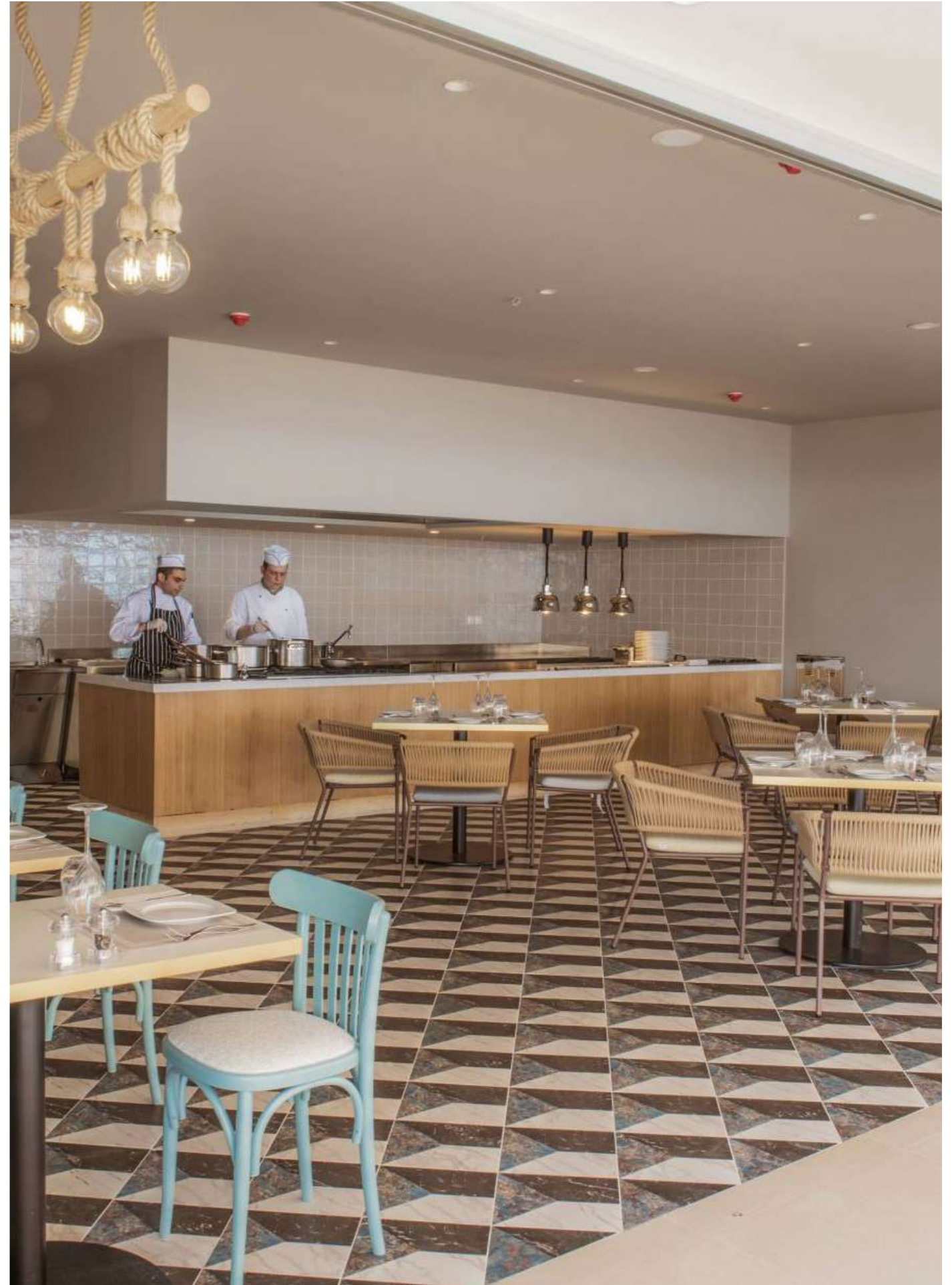



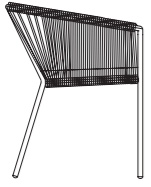
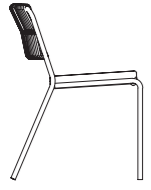

Puffs

ARENA

BOX

DIABOLO

FUP

GOLF

GLOBE

KENYA

LONG ISLAND

PAL

PUL

RUEDO

SIR

T

TAHITI

U

WEAVE

WEEKEND

PUFS



ARENA
Ref. 70052 | NO MOQ

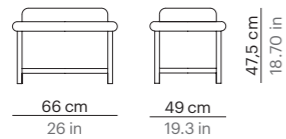

BOX
Ref. 71452 | MOQ 10

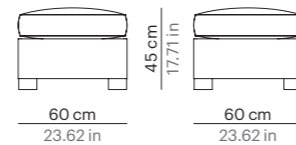

DIABOLO
Ref. 74152 | MOQ 10

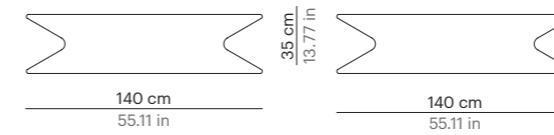

FUP
Ref. 77751 | NO MOQ

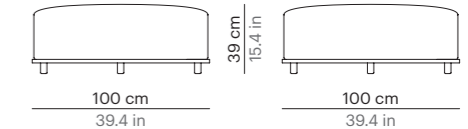

DIABOLO
Ref. 74150 | MOQ 10

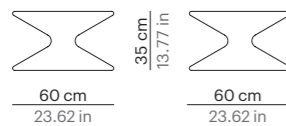

DIABOLO
Ref. 74151 | MOQ 10

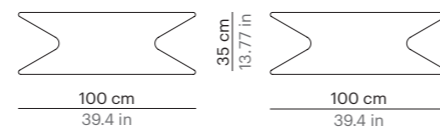

FUP
Ref. 77752 | NO MOQ

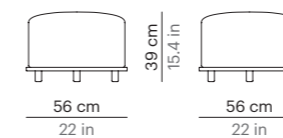

GOLF
Ref. 71552 | MOQ 10

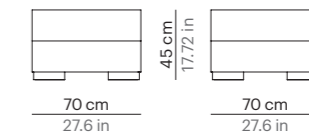

GLOBE

Ref. 71650 | MOQ 10

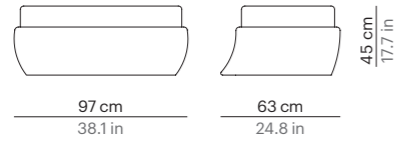

KENYA

Ref. 73452 | MOQ 10

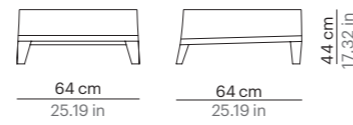

PUL

Ref. 76652 | MOQ 10

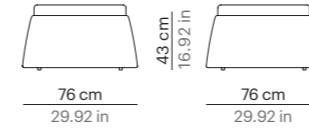

RUEDO

Ref. 71652 | MOQ 10

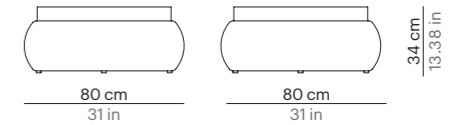

LONG ISLAND

Ref. 77852 | NO MOQ

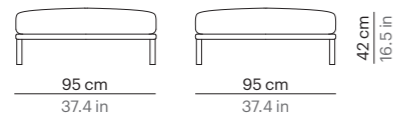

PAL

Ref. 7704505 | NO MOQ

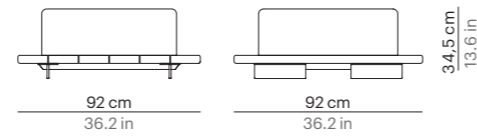

RUEDO

Ref. 71651 | MOQ 10

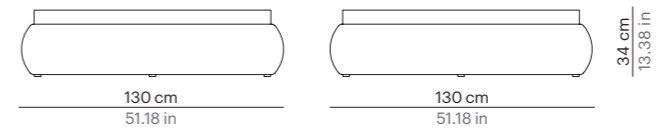

SIR

Ref. 77252 | MOQ 100

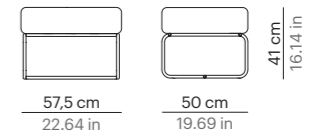

PAL

Ref. 7704400 | NO MOQ

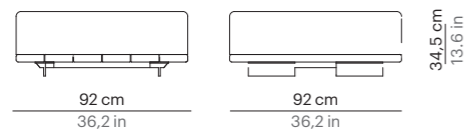

PUL

Ref. 76651 | MOQ 10

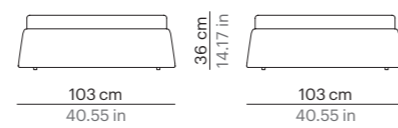

T

Ref. 77452 | MOQ 50

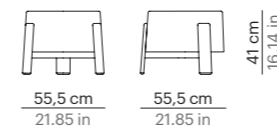

TAHITI

Ref. 72052 | MOQ 10

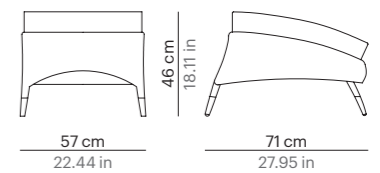

U
Ref. 74252 | MOQ 10

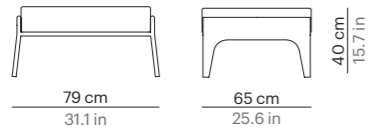

WEAVE
Ref. 77155 | NO MOQ

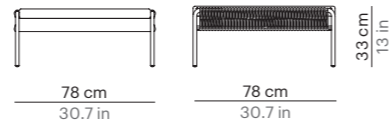

WEAVE
Ref. 78155 | NO MOQ

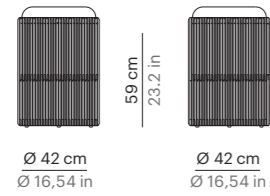

WEAVE
Ref. 78152 | NO MOQ

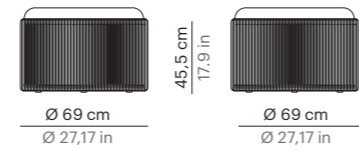

WEAVE
Ref. 78158 | NO MOQ

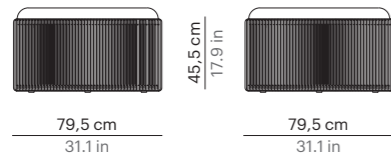

WEEKEND
Ref. 73152 | MOQ 50

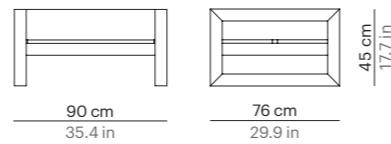

Bar Stools

AMBERES
ARC
BOX
PARALEL

ROUND
T
U
WEAVE

BAR STOOLS



AMBERES
Ref. 72252 | MOQ 10

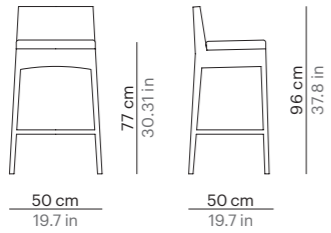

ARC
Ref. 76252 | NO MOQ

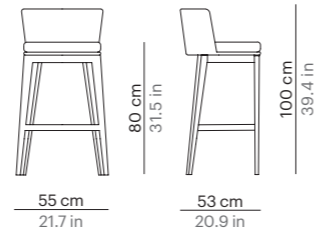

ROUND
Ref. 76552 | MOQ 10

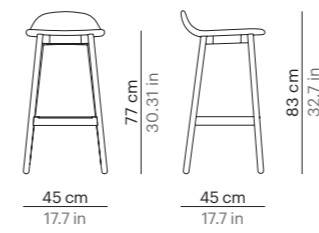

T
Ref. 77451 | MOQ 50

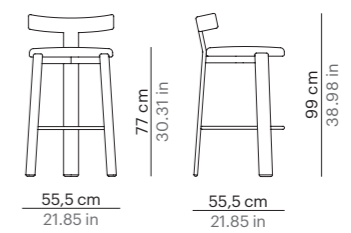

BOX
Ref. 71451 | MOQ 10

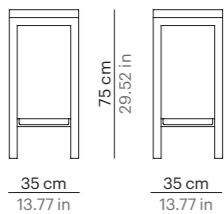

PARALEL
Ref. 77652 | NO MOQ

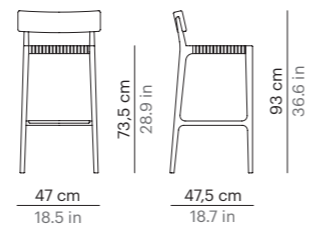

U
Ref. 74257 | MOQ 10

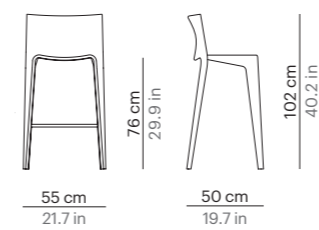

WEAVE
Ref. 77152 | NO MOQ

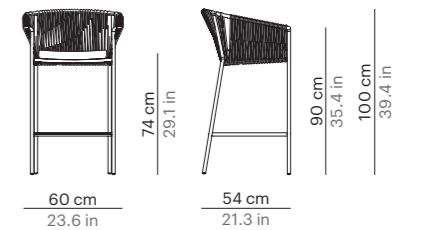

PROJECTS



WALD- ORF ASTORIA



MALDIVES
BUBBLE, GOLF
COLLECTIONS

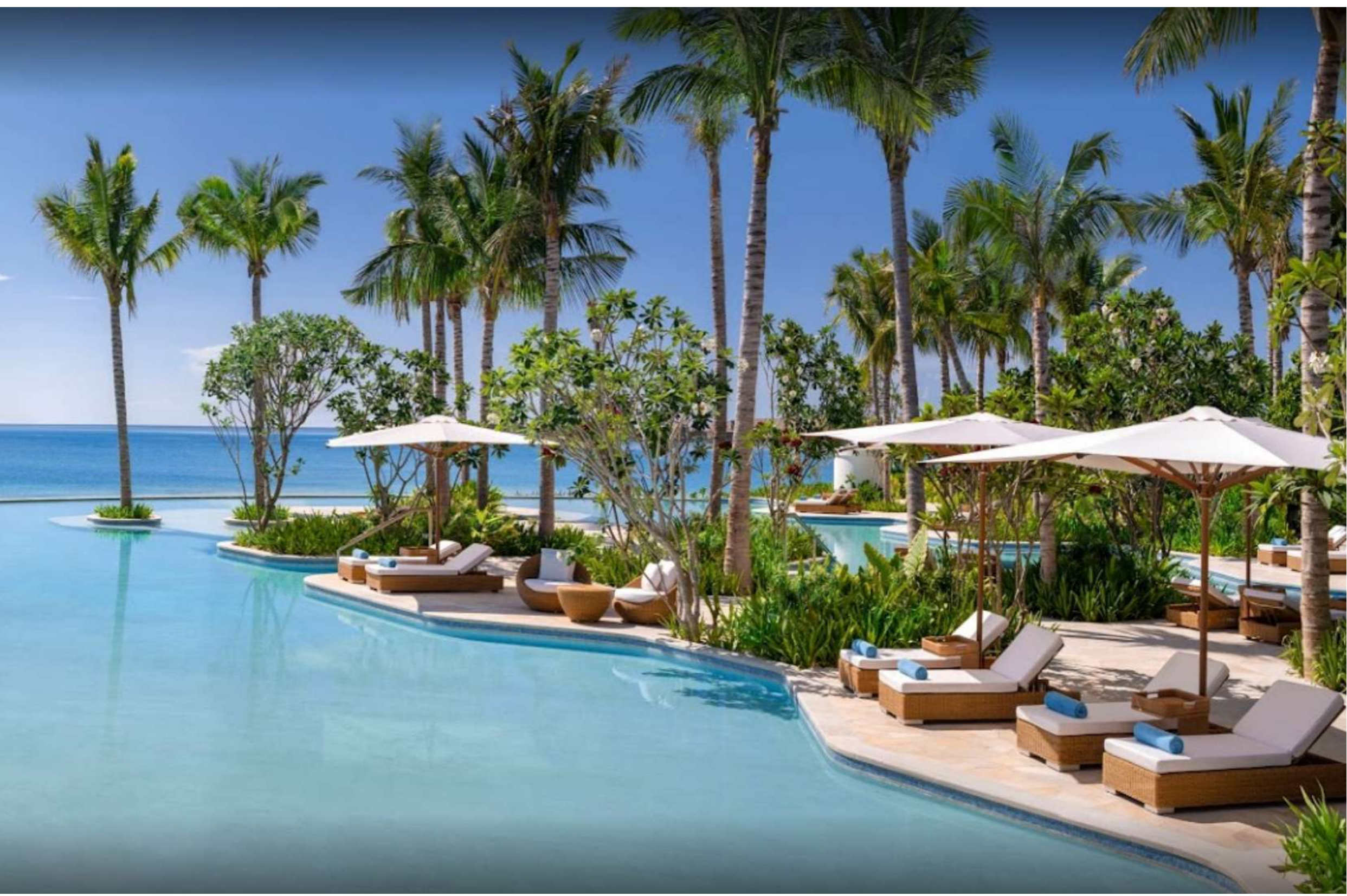
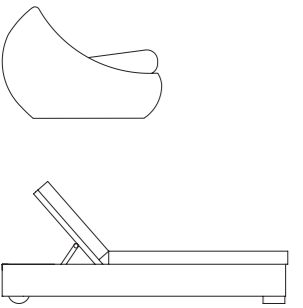

Sunbeds

ARENA
BAHÍA
BAY
BANOI
BREDA
CALIMA
GOLF
HERITAGE

ICPALLI
JAZZ
LINEAL
LONG ISLAND
PAL
PARALEL
ROMANTIC

SAMOA
SIESTA
SUNSET
U
WEAVE
WEEKEND
ZOE

SUNBEDS



ARENA
Ref. 70095 | NO MOQ

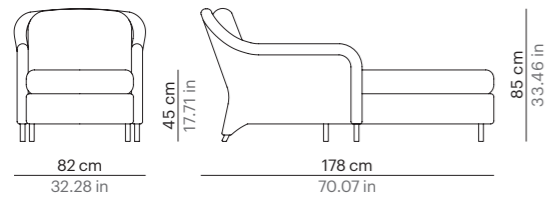

BAHÍA
Ref. 71096 | MOQ 10

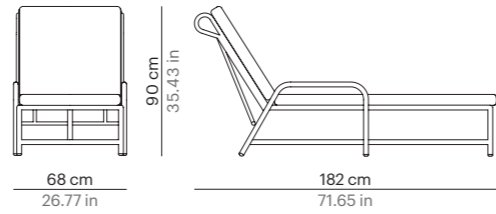

BANOI
Ref. 79096 | MOQ 100

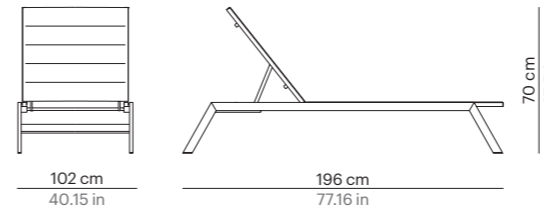

BREDA
Ref. 72095 | NO MOQ

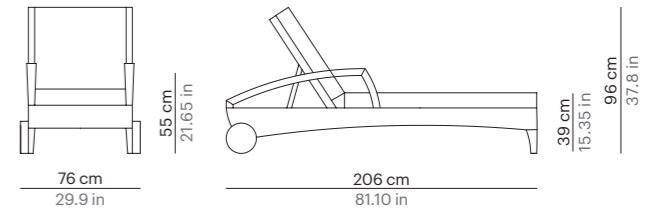

BAY
Ref. 78495 | NO MOQ

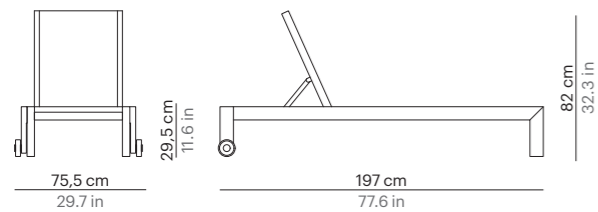

BANOI
Ref. 79095 | MOQ 100

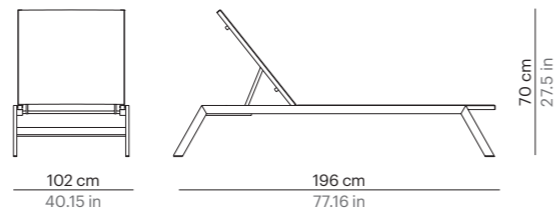

CALIMA
Ref. 71396 | MOQ 10

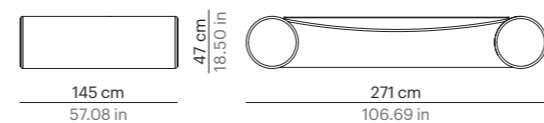

GOLF
Ref. 71595 | MOQ 5

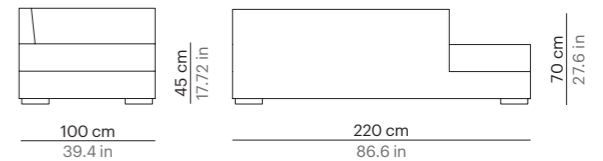

GOLF
Ref. 71597 | MOQ 5

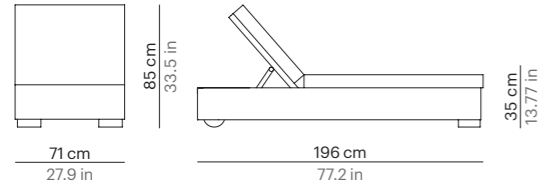

GOLF
Ref. 71596 | MOQ 5

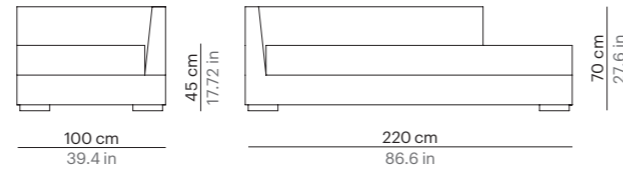

ICPALLI
Ref. 76095 | MOQ 10

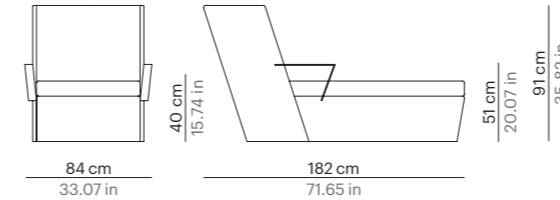

HERITAGE
Ref. 78595 | NO MOQ

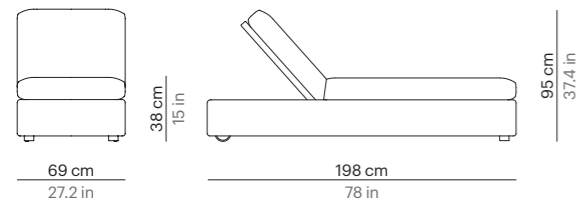

HERITAGE
Ref. 78696 | NO MOQ

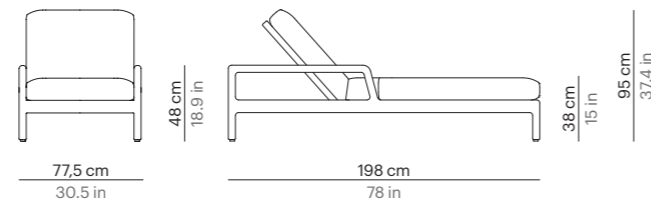

JAZZ
Ref. 73995 | NO MOQ

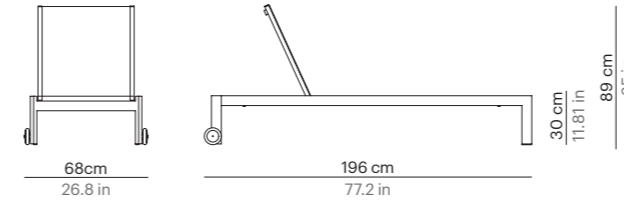

LINEAL
Ref. 76397 | MOQ 5

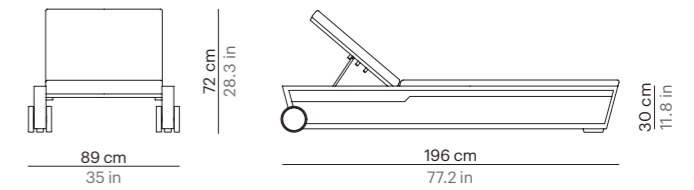

HERITAGE
Ref. 78795 | NO MOQ

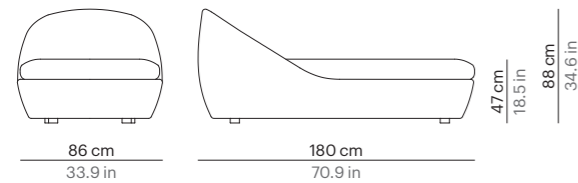

HERITAGE
Ref. 78796 | NO MOQ

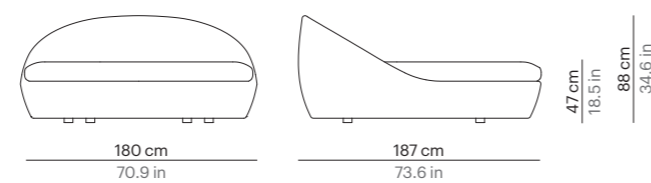

LINEAL
Ref. 76395 | MOQ 10

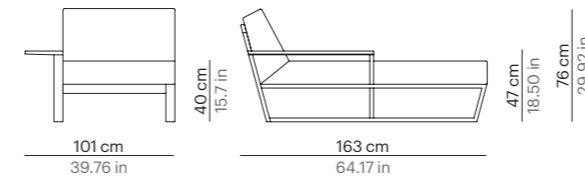

LINEAL
Ref. 76195 | MOQ 10

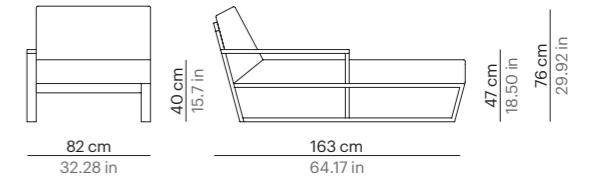

LINEAL
Ref. 76396 | MOQ 10

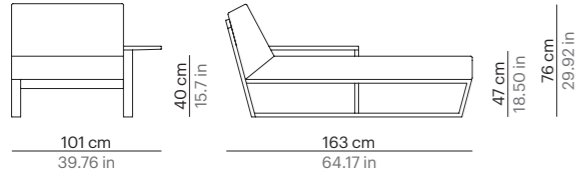

LINEAL
Ref. 76196 | MOQ 10

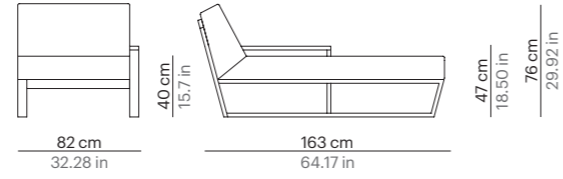

LONG ISLAND
Ref. 77897 | NO MOQ

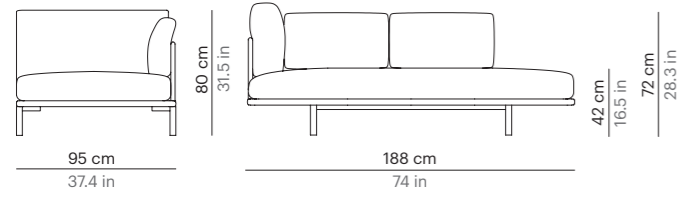

LONG ISLAND
Ref. 77896 | NO MOQ

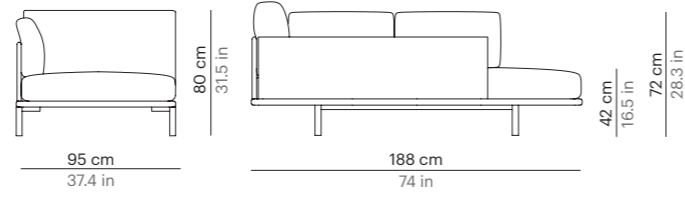

PAL
Ref. 7709504 | NO MOQ

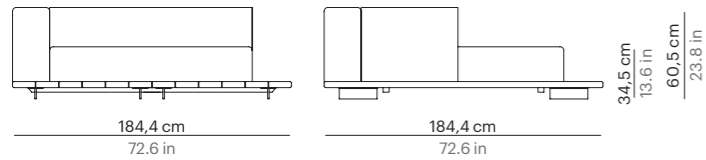

PAL
Ref. 7709503 | NO MOQ

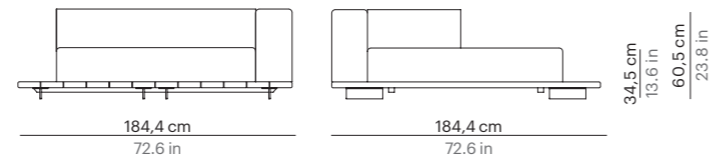

PAL
Ref. 7709502 | NO MOQ

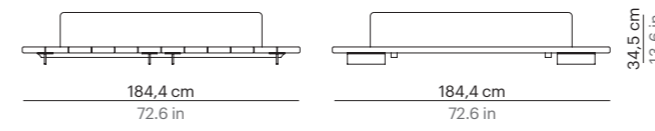

PAL
Ref. 7709501 | NO MOQ

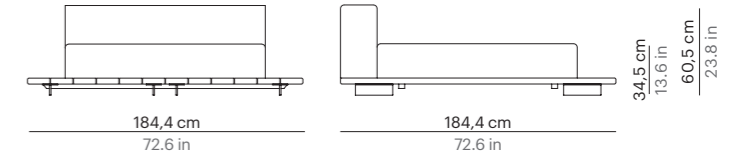

PAL
Ref. 7709506 | NO MOQ

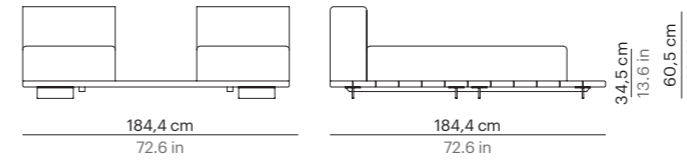

PAL
Ref. 7709505 | NO MOQ

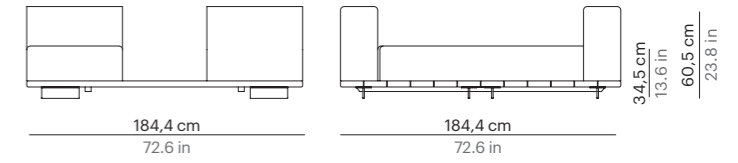

PARALEL
Ref. 77695 | NO MOQ

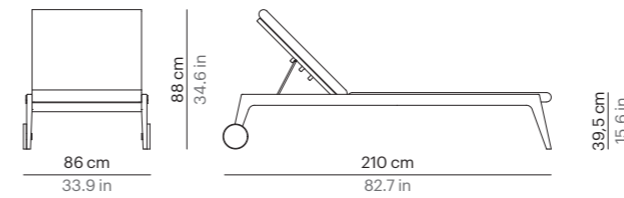



SAMOA

Ref. 78995 | MOQ 100

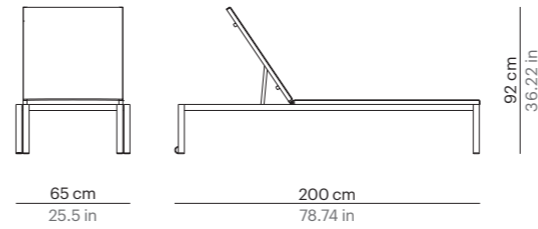

SAMOA

Ref. 78996 | MOQ 100

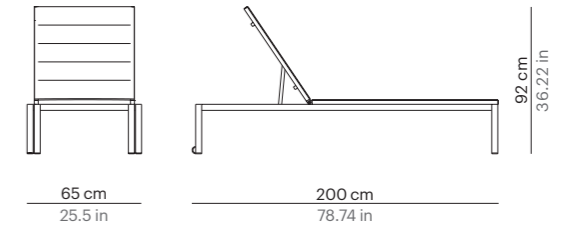

SIESTA

Ref. 74095 | MOQ 10

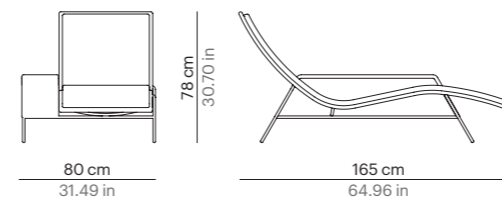

SUNSET

Ref. 74495 | NO MOQ

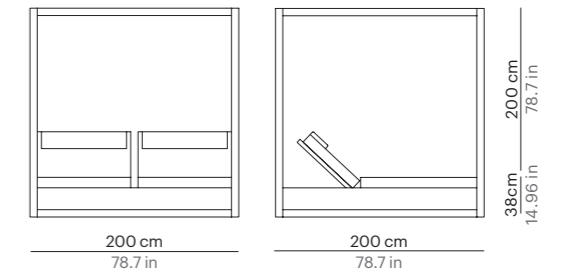

ROMANTIC

Ref. 71698 | NO MOQ

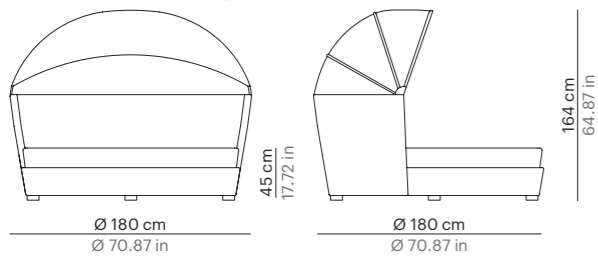

ROMANTIC

Ref. 71697 | NO MOQ

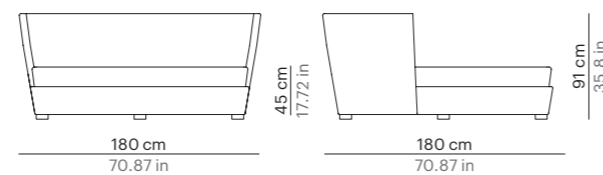

SUNSET

Ref. 74496 | NO MOQ

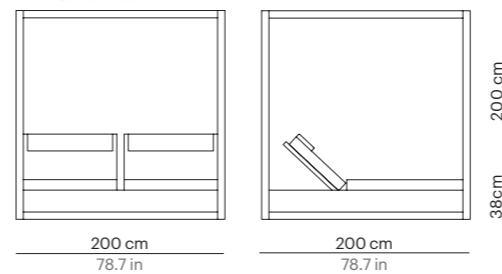

U

Ref. 74195 | MOQ 5

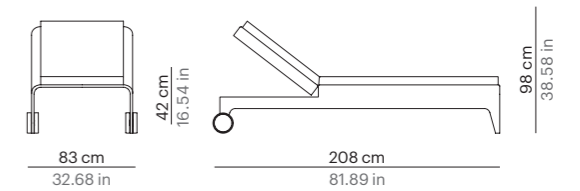

U
Ref. 74296 | MOQ 5

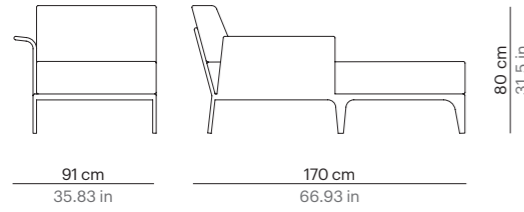

U
Ref. 74297 | MOQ 5

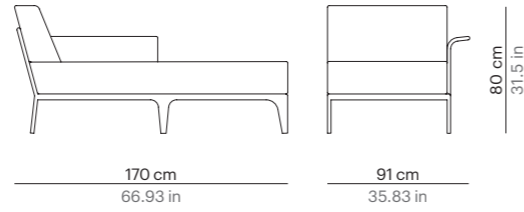

WEAVE
Ref. 78195 | NO MOQ

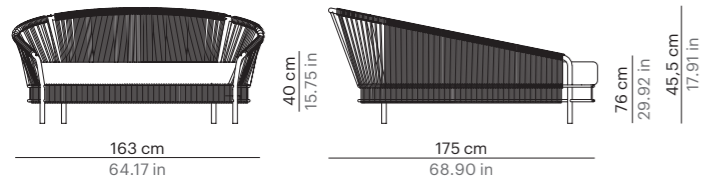

WEAVE
Ref. 77197 | MOQ 10

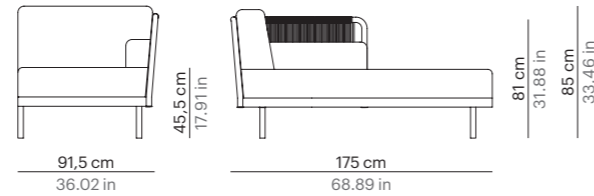

WEAVE
Ref. 77196 | MOQ 10

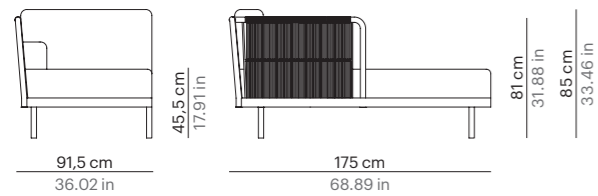

WEAVE
Ref. 77195 | NO MOQ

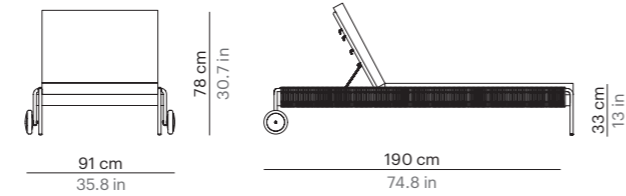

WEEKEND
Ref. 73198 | MOQ 80

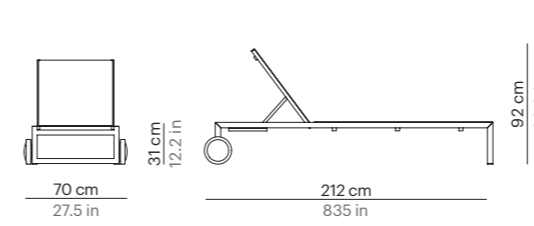

ZOE
Ref. 72195 | MOQ 10

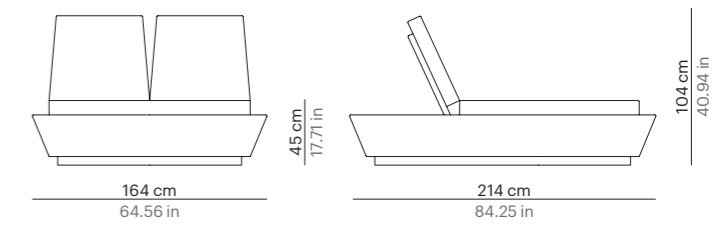

ZOE
Ref. 72196 | MOQ 10

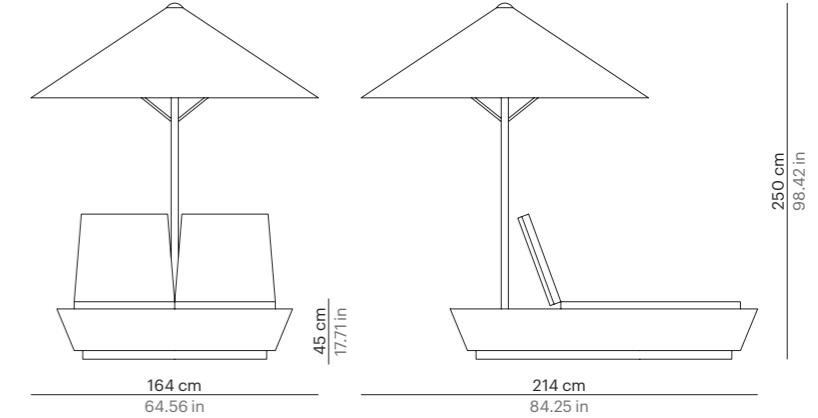

Swings

ARMADILLO
WEAVE

SWINGS

ARMADILLO
Ref. 76945 | MOQ 5

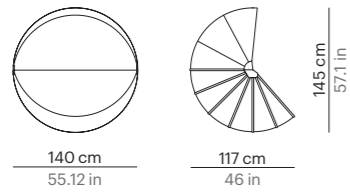

ARMADILLO
Ref. 76946 | MOQ 5

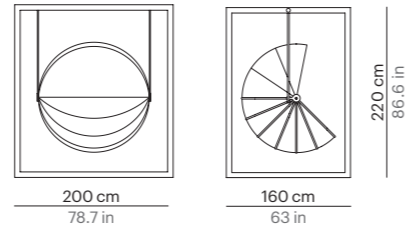

WEAVE
Ref. 77193 | NO MOQ

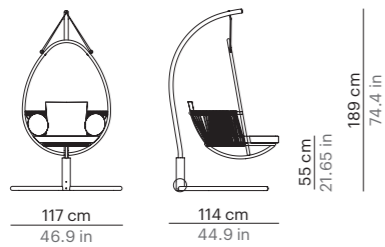

WEAVE
Ref. 77192 | NO MOQ

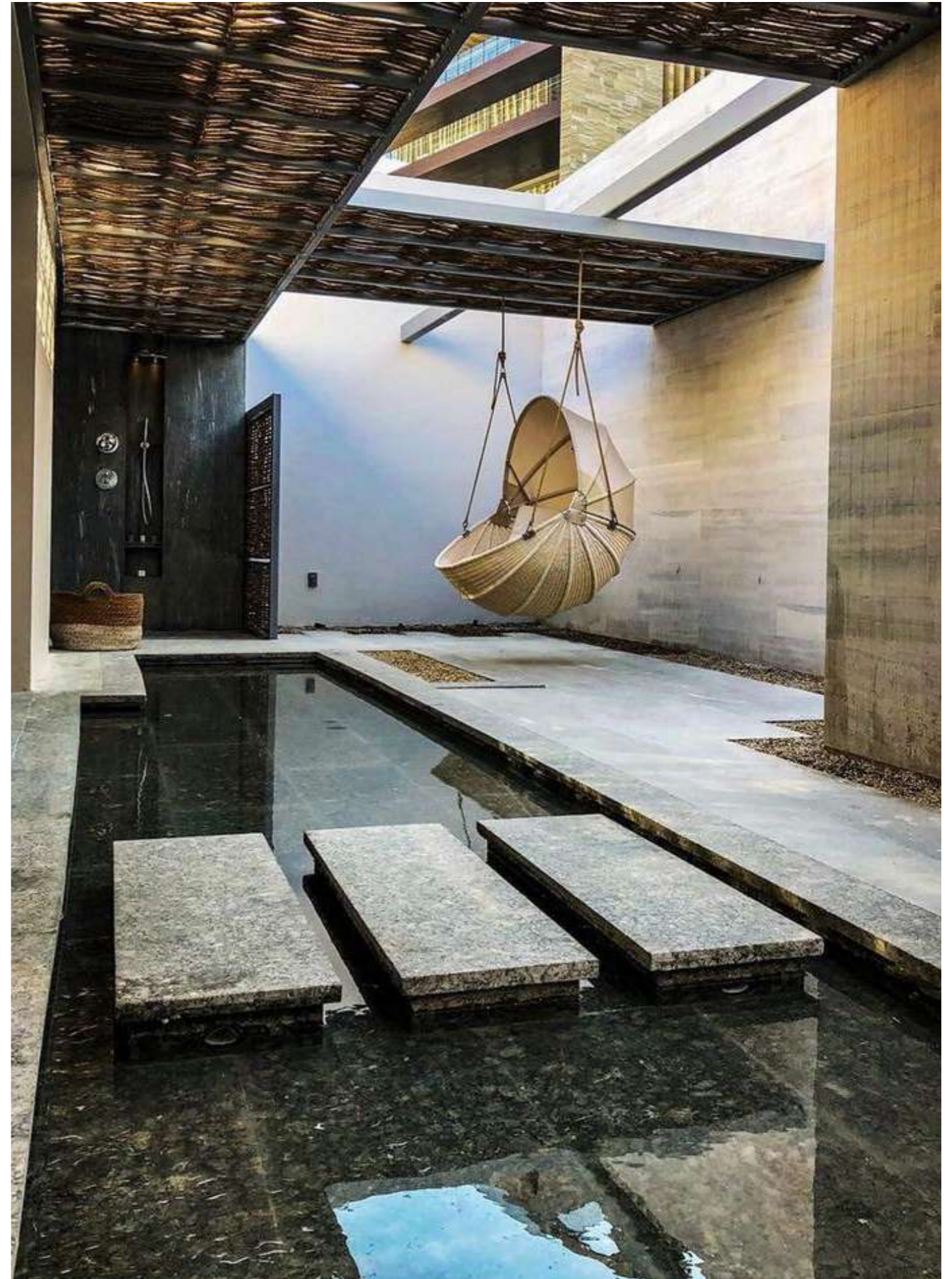
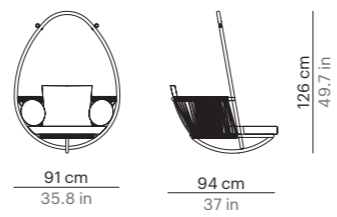

Umbrellas

BEACH
OMBRA
ROMA

UMBRELLAS

BEACH
Ref. 8460103 | NO MOQ

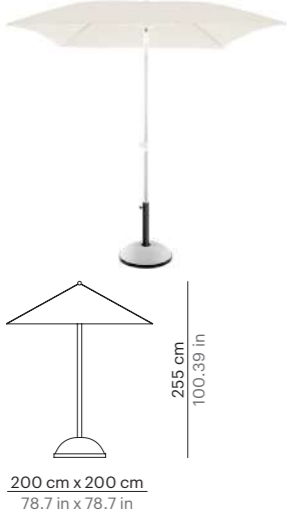

BEACH
Ref. 8460104 | NO MOQ

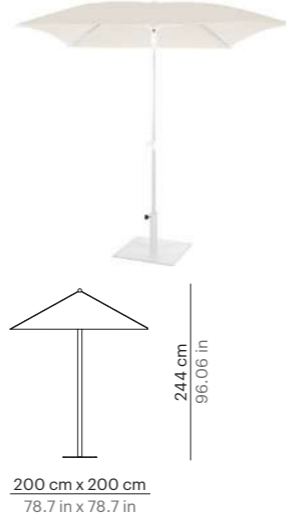

OMBRA
Ref. 84804 | NO MOQ



ROMA
Ref. 84702 | NO MOQ

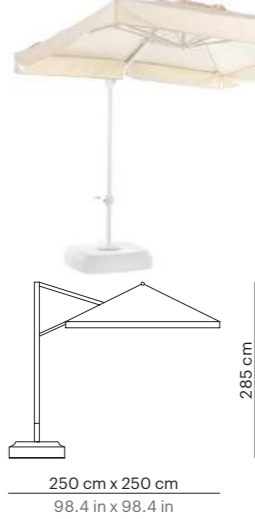

BEACH
Ref. 8460203 | NO MOQ

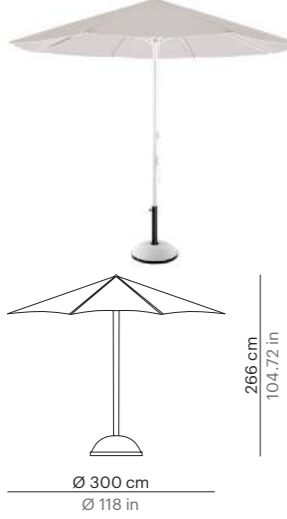

BEACH
Ref. 8460204 | NO MOQ

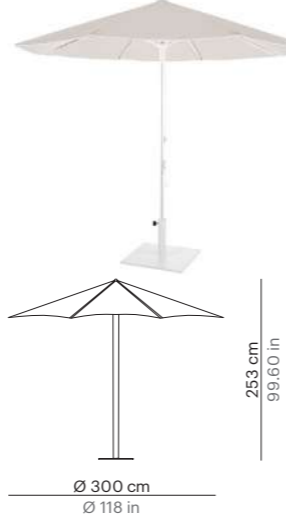

ROMA
Ref. 84703 | NO MOQ

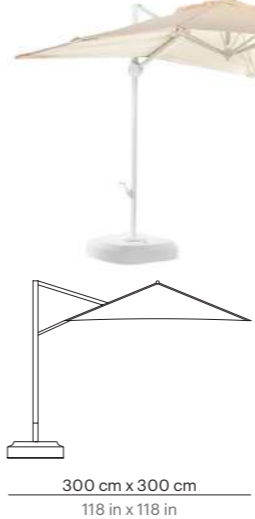

ROMA
Ref. 84701 | NO MOQ

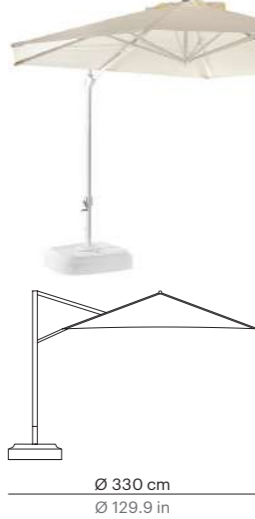

Planters

BOX
GOLF
MIST
WEAVE

PLANTERS



BOX
Ref. 71482 | MOQ 10

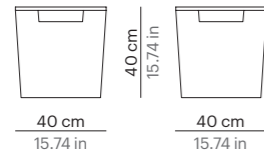

BOX
Ref. 71481 | MOQ 10

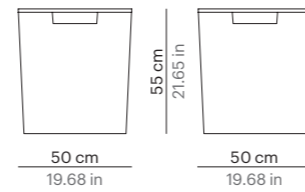

GOLF
Ref. 71581 | MOQ 10

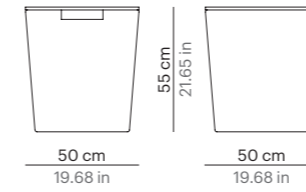

GOLF
Ref. 71580 | MOQ 10

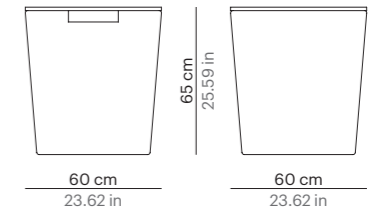

BOX
Ref. 71480 | MOQ 10

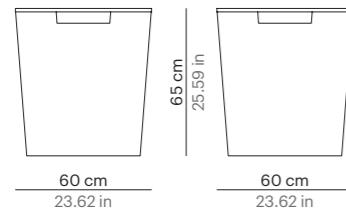

GOLF
Ref. 71582 | MOQ 10

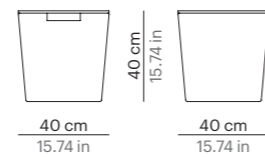

MIST
Ref. 76482 | MOQ 5

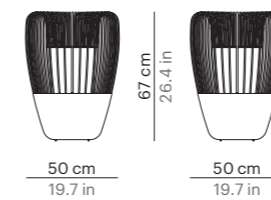

MIST
Ref. 76481 | MOQ 5

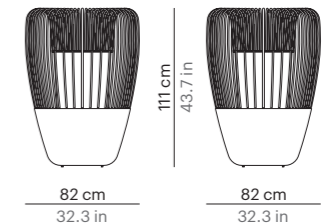

MIST

Ref. 76480 | MOQ 5

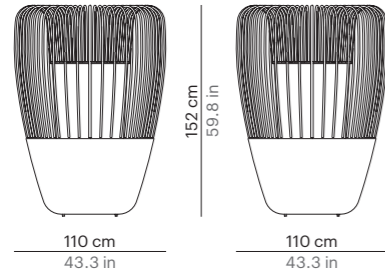

WEAVE

Ref. 78151 | NO MOQ

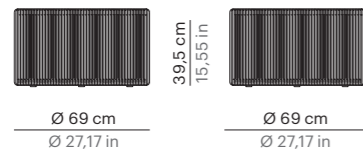

WEAVE

Ref. 78157 | NO MOQ

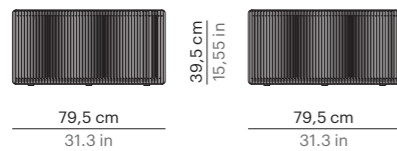

**TRAY ADAPTED TO EACH
PLANTER**

Material Aluminium



WEAVE

Ref. 78154 | NO MOQ

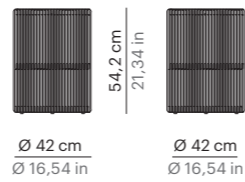

Lamps

LAMPS

MIST
Ref. 76472 | MOQ 5

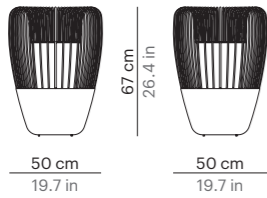

MIST
Ref. 76471 | MOQ 5

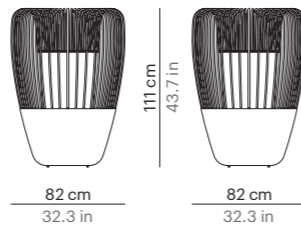

MIST
Ref. 76470 | MOQ 5

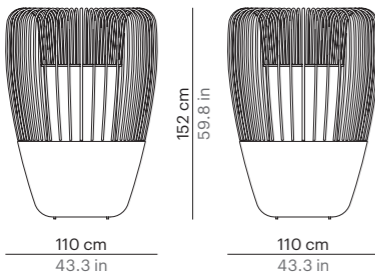

LAMP
6*1 W



LAMP
9*1 W



LED chip bridgelux
Input voltage: 85-240VAC. 50-60 hz.
Cable 2 meters + EU plug
CCT warm white (2800 - 3000 k)
Beam angle 60 degree
all stainless steel body
IP67
Stanco system

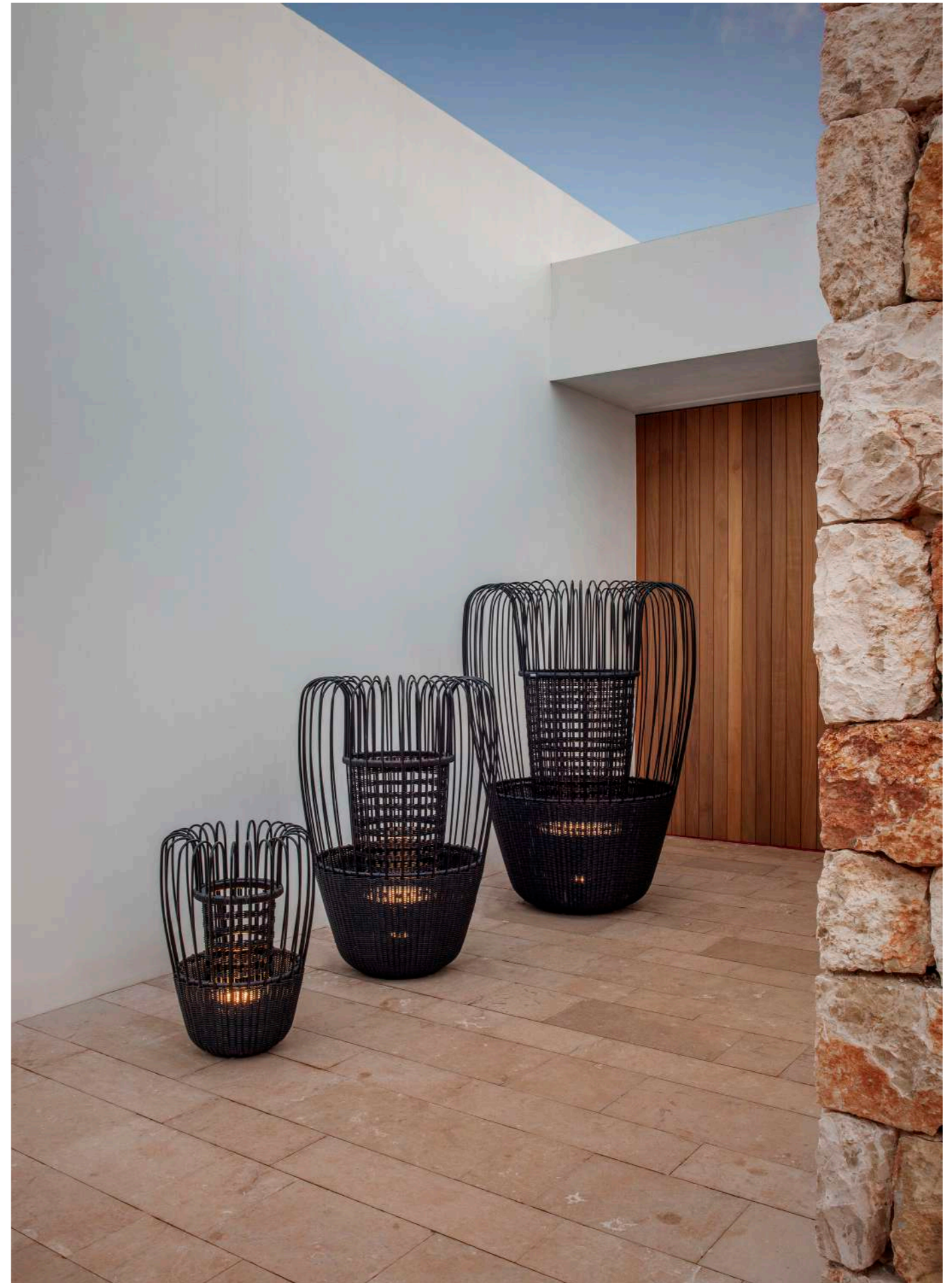

Accessories

GREEN
PUL
COVERS

ACCESORIES

GREEN
Ref. 76970 | NO MOQ

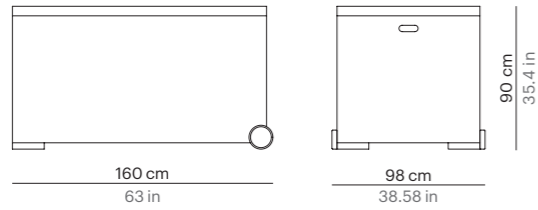

GREEN
Ref. 76971 | MOQ 5

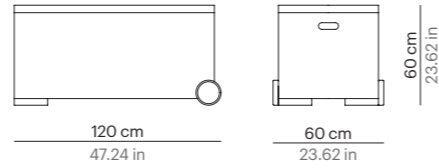

PUL
Ref. 76670 | MOQ 10

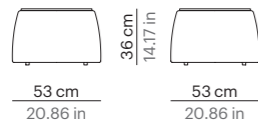

PUL
Ref. 76671 | MOQ 10

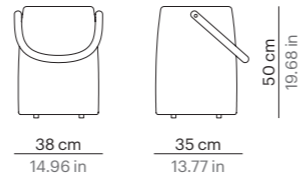

COVERS
Adapted to each model



Indoor

AITANA
BENASSAL
GADEA

KIF
MAFALDA
ZEROS

INDOOR



AITANA

Ref. 65006 | MOQ 10

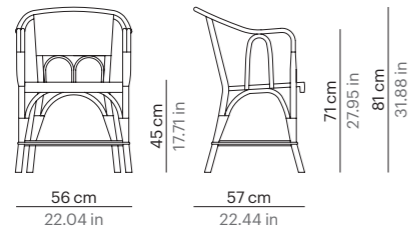

BENASSAL

Ref. 65007 | MOQ 10

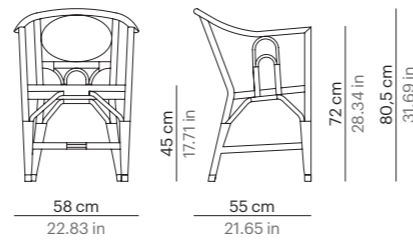

KIF

Ref. 65154 | MOQ 10

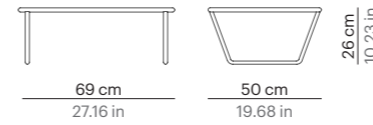

MAFALDA

Ref. 65101 | MOQ 10

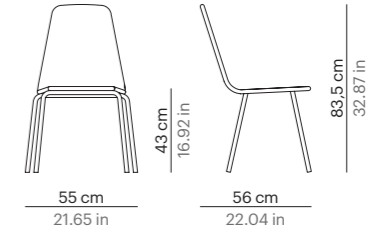

GADEA

Ref. 65045 | MOQ 10

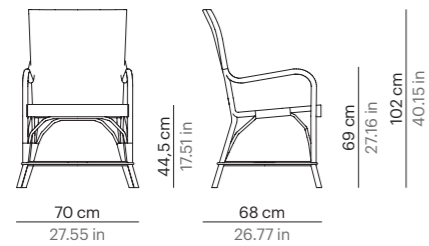

KIF

Ref. 65145 | MOQ 10

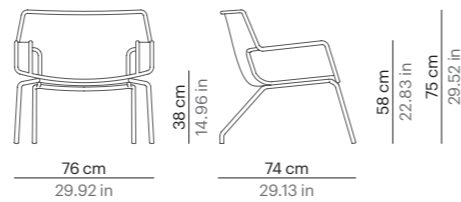

ZEROS

Ref. 65106 | MOQ 10

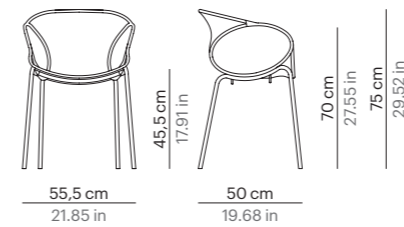

FINISHES AND MAINTENANCE

ACABADOS Y MANTENIMIENTO

Es la fibra sintética para muebles de exterior inspirada en la naturaleza y perfeccionada técnicamente hasta alcanzar el máximo nivel de confort, funcionalidad y durabilidad. El Shintotex® está compuesto por PP y PE más componentes catalizadores como filtros UV, pigmentos, aditivos anti-estáticos y elementos plastificantes.

Características técnicas:

Resistencia a cambios climatológicos.
 Resistencia a agentes químicos abrasivos.
 Resistencia a rotura y deterioro por el uso.
 Alta flexibilidad.
 Total reciclaje.

Características estéticas:

Calidez y apariencia natural.
 Tacto agradable.
 Variedad de texturas y trenzados.
 Fácil limpieza.
 Mayor ligereza.

Limpieza y mantenimiento

Pasar cepillo de cerdas suaves sobre el tejido para eliminar el polvo o utilizar solución jabonosa de pH neutro para la limpieza de residuos o manchas. Evitar el contacto con productos abrasivos (lejías, cloro, aceites, productos con ácidos o sustancias corrosivas en su composición).

This is a synthetic fibre for outdoor furniture, inspired by nature and perfected by technology to achieve maximum comfort, functionality and durability. Shintotex® is made of PP and PE, as well as catalysts, such as UV filters, pigments, additives, anti-static agents and plasticisers.

Technical features:

*Resistant to changing weather conditions.
 Resistant to abrasive chemical agents.
 Resistant to breakage and to wear and tear.
 Highly flexible.
 Fully recyclable.*

Aesthetic features:

*Warm, natural appearance.
 Pleasant to the touch.
 Variety of textures and braids.
 Easy to clean.
 Lighter weight.*

Maintenance and cleaning

Use a soft-bristled brush to remove any dust from the weave. Also, a soapy solution of neutral pH can be used to clean any residue or marks. Avoid contact with abrasive products (bleach, chlorine, oils, products containing corrosive acids or substances).

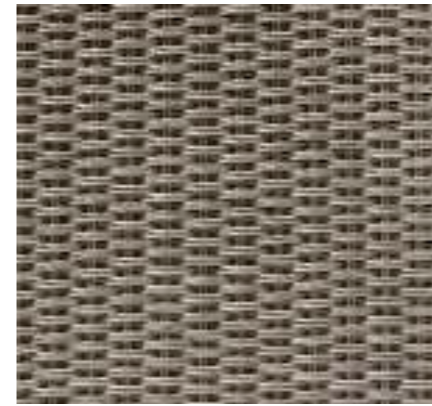

Round Ø3 mm Gris Plata / Silver Grey



Round Ø3 mm Blanco / White

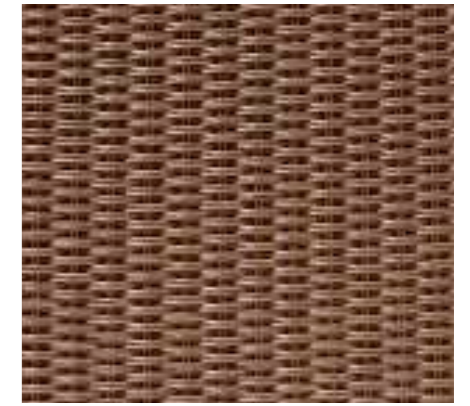

Round Ø3 mm Marrón Castaño / Chestnut Brown



Round Ø3 mm Gris Oscuro / Dark Grey



Round Ø6 mm Moss Brown

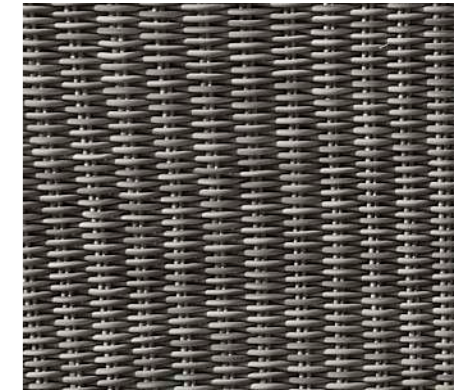

Round Ø6 mm Ash Grey

 Round 3-4 mm
 Marfil 36 Ivory 36

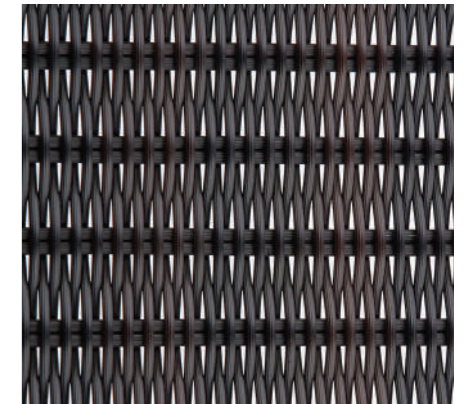
 Round 3-4 mm
 Tostado 03 Toasted 03

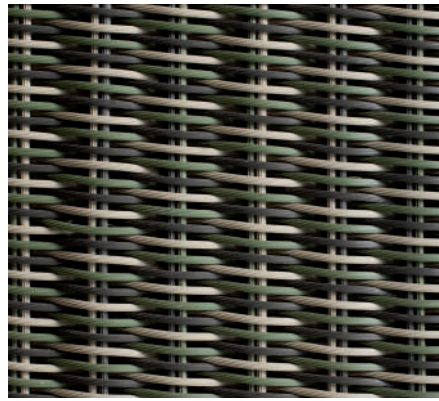
 Round 3-4 mm
 Dark 59



Round 3-4 mm
Multicolor 10 *Multicoloured 10*

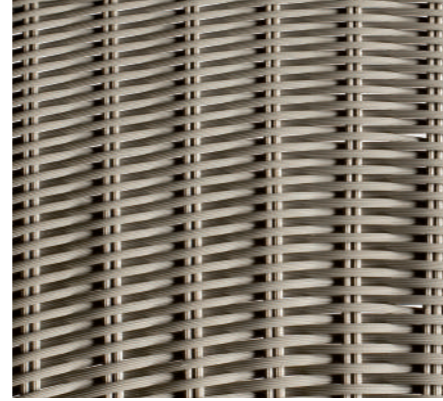

Round 3-4 mm
Gris Umbra 12 *Umbra Grey 12*



Round 3-4 mm
Gris Claro 11 *Light Grey 11*

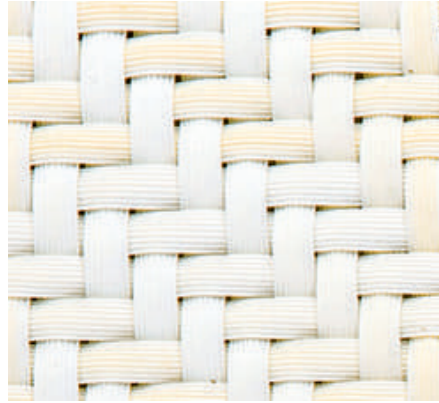

Flat oval 6 mm
Marfil 36 *Ivory 36*

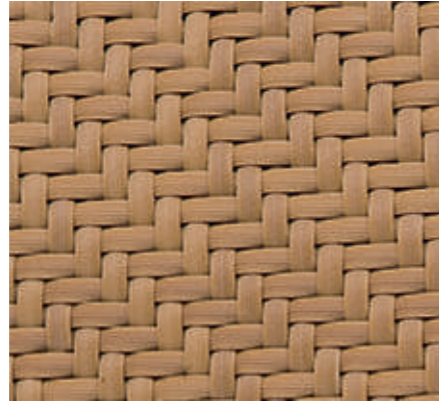

Flat oval 6 mm
Tostado 03 *Toasted 03*

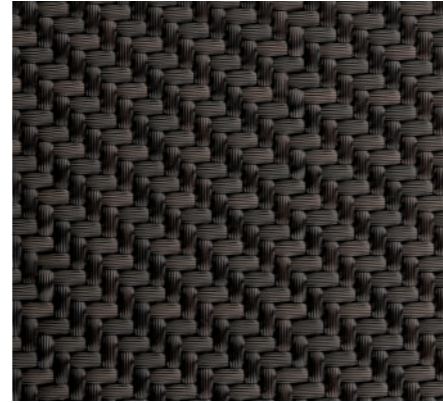

Flat oval 6 mm
Dark 59



Flat 7 mm
Blanco 35 *White 35*

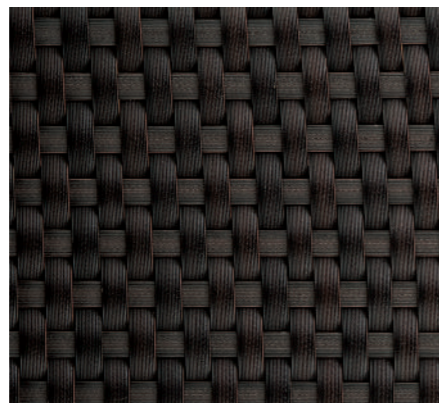

Flat 9 mm
Dark 59

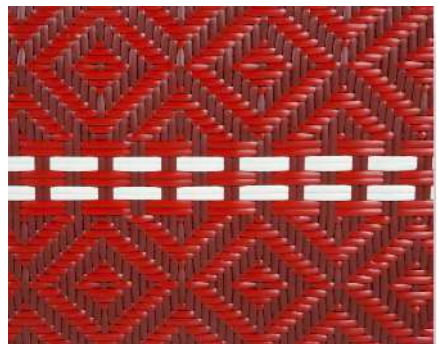

Flat 7 mm
Rojo Icpalli 08 *Red Icpalli 08*

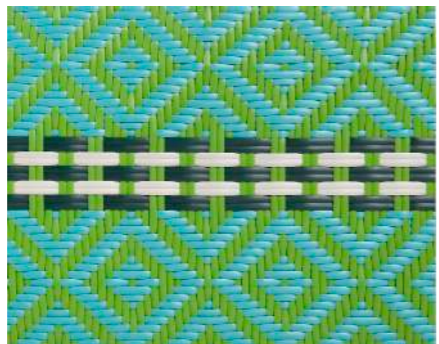

Flat 7 mm
Verde Icpalli 09 *Green Icpalli 09*

Cuerda Rope

Ø4mm

City Collection
Summer Collection



Tanto el ánima como el recubrimiento del cordón es de polipropileno para conseguir una mayor solidez a la luz e intemperie. Además, lleva un filtro de color para mayor fijación.

Limpieza y mantenimiento

Utilizar solución jabonosa de pH neutro para la limpieza de residuos o manchas. Evitar el contacto con productos abrasivos (lejías, cloro, aceites, productos con ácidos o sustancias corrosivas en su composición).

Both the rope itself and its coating are made from polypropylene to ensure greater resistance to light and weather. It also includes a colour filter for greater fixing.

Maintenance and cleaning

A soapy solution with a neutral pH can be used to clean any dirt or marks. Avoid contact with abrasive products (bleach, chlorine, oils, products containing acids or corrosive substances).



ALUMINIO - CUERDA | 34 Crema - Beige
ALUMINIUM - ROPE | 34 Cream - Beige



Beige
Beige



ALUMINIO - CUERDA | 74 Arena - Gris perlado
ALUMINIUM - ROPE | 74 Sand - Pearl grey

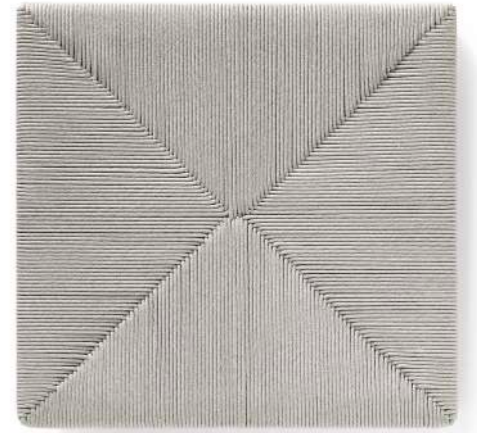

Gris perlado
Pearl grey

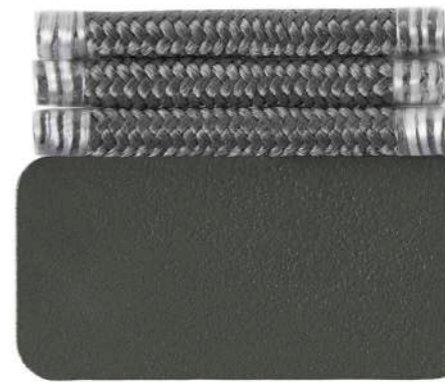

ALUMINIO - CUERDA | 56 Gris metalizado - Grafito
ALUMINIUM - ROPE | 56 Gunmetal grey - Graphite



Grafito
Graphite

Cuerda Sintética Synthetic Rope

Paralel Collection

Cuerda sintética para muebles de exterior compuesta de polietileno de alta densidad. Cuenta con un alto nivel de confort, funcionalidad y durabilidad.

Características técnicas:

Resistencia a cambios climatológicos.
Resistencia a rotura y deterioro por el uso.
Alta flexibilidad.
Total reciclaje.

Características estéticas:

Calidez y apariencia natural.
Tacto agradable.
Fácil limpieza.
Mayor ligereza.

Limpieza y mantenimiento

Pasar cepillo de cerdas suaves sobre la cuerda para eliminar el polvo, o utilizar solución jabonosa de pH neutro para la limpieza de residuos o manchas. Evitar el contacto con productos abrasivos (lejías, cloro, aceites, productos con ácidos o sustancias corrosivas en su composición).

Synthetic rope for outdoor furniture. A high-density polyethylene compound that offers a high level of comfort, functionality and durability.

Technical features:

*Resistant to changing weather conditions.
Resistant to breakage and to wear and tear.
Highly flexible.
Totally recycled.*

Aesthetic features:

*Warm, natural appearance.
Pleasant to the touch.
Easy to clean.
Lighter weight.*

Maintenance and cleaning

Brush the rope with a soft-bristled brush to remove any dust, or use a soapy solution with a neutral pH to clean any residue or marks. Avoid contact with abrasive products (bleach, chlorine, oils, products containing acids or corrosive substances).

Cuerda Rope

Ø8 mm



Cuerda elaborada en hilo de poliéster, totalmente apta para exteriores. Ofrece gran resistencia a la luz (7 sobre 8) y a la intemperie.

Limpieza y mantenimiento

Utilizar solución jabonosa de PH neutro para la limpieza de residuos o manchas. Evitar el contacto con productos abrasivos (lejías, cloro, aceites, productos con ácidos o sustancias corrosivas en su composición).

Polyester rope for outdoor use. Offers great lightfastness (7 out of 8) and weather resistance.

Maintenance and cleaning

A soapy solution with a neutral pH can be used to clean residue or marks. Avoid contact with abrasive products (bleach, chlorine, oils, products containing corrosive acids or substances).

Weave Collection



61 Crema - Turrón / Cream - Nougat

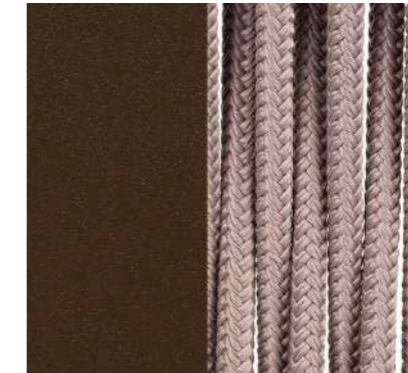

60 Gris - Taupe / Grey - Taupe



63 Gris - Turrón / Grey - Nougat

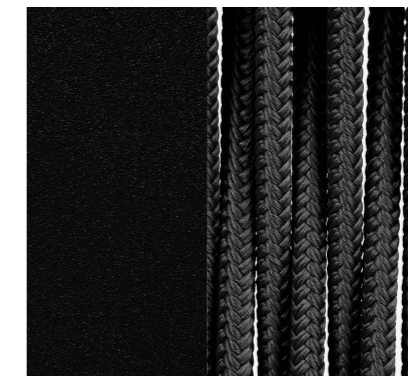

59 Negro / Black

Khai Collection



Turrón / Nougat



Taupe / Taupe



Negro / Black

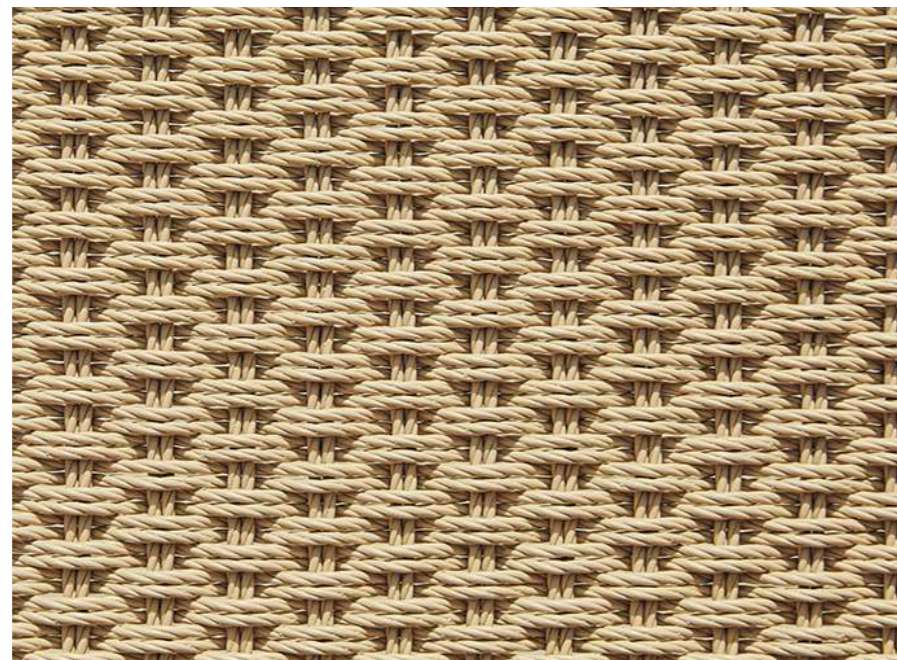

Trenzado Cuerda sintética Ø 4 mm
Woven Synthetic cord Ø 4 mm

Aluminio pintado en polvo
Powder coated aluminium

Con resina epóxica como ligante, para incrementar la resistencia a la corrosión, abrasión y a los agentes químicos.

With epoxy resin used as a binder to increase resistance to corrosion, abrasion and chemical agents.

Limpieza y mantenimiento

Maintenance and cleaning

Utilizaremos bayetas suaves o esponjas que no rayen la superficie y agua con jabón o detergentes neutros diluidos en agua; nunca productos abrasivos. Después se enjuagará con agua limpia y se secará con un paño, para evitar que el detergente afecte al material.

Use soft cloths or sponges that will not scratch the surface with soap and water or neutral detergents diluted in water; never use abrasive products. Then rinse with clean water and dry with a cloth to prevent the detergent from affecting the material.



Blanco nieve 70
White snow 70



Crema 34
Cream 34



Arena 74
Sand 74



Gris taupe 60
Taupe grey 60



Óxido 75
Rust 75



Gris metalizado 56
Gunmetal grey 56



Terracota 72
Terracotta 72



Verde ficus 73
Green ficus 73



Azul cielo 71
Blue sky 71



Negro 59
Black 59

Se trata de un material porcelánico elaborado de 12 mm de espesor.

Características técnicas:

Impermeable y resistente a líquidos, con un nivel de absorción próximo a cero. Resistente al rayado y a la abrasión gracias a la dureza de su superficie. No se quema en contacto con el fuego ni emite humo ni sustancias tóxicas al ser sometido a altas temperaturas. Resistente a cualquier tipo de agente químico de limpieza. No desprende sustancias nocivas. Es totalmente apto para el contacto con los alimentos. Certificado NSF. Siendo 100% natural, los colores no se desvirtúan cuando el material se expone al sol o a condiciones meteorológicas extremas. No desprende ninguna sustancia nociva para el entorno. Hasta un 52% de material reciclado en cada tabla. 100% reciclable. 30 kg/m² en la tabla de 12 mm. Módulo de rotura elevado. Resistente a altas cargas de presión y peso.

Limpieza y mantenimiento

Tiene una limpieza fácil ya que no pueden penetrar en el material los restos de comida y residuos que se depositen por lo que garantizan una buena higiene. Para la mayoría de los casos, sólo bastará con un paño húmedo para limpiarlo. Use un paño de microfibra para quitar el polvo de la superficie. Se puede lavar con agua tibia, a la cual se le puede agregar un detergente en la dosis de uso recomendado por el fabricante. (Deben evitarse productos que contengan ácido fluorhídrico y sus derivados). Enjuagar con agua tibia y secar con bayetas o algo similar.

This is a 12-mm thick porcelain material.

Technical features:

Waterproof and resistant to liquids, with an absorption level close to zero. Scratch and abrasion resistant thanks to the hardness of the surface. No combustion takes place in contact with fire and no smoke or toxic substances are released when it is subjected to high temperatures. Resistant to any type of chemical or cleaning agent. No dangerous substances are given off. It is totally apt for contact with foodstuffs. NSF certified. As it is 100% natural, the colours do not fade when exposed to sunlight or subjected to extreme weather conditions. No dangerous substances that may harm the environment are given off. Each piece contains up to 52% recycled material. 100% recyclable. 30 kg/m² in a 12 mm piece. Highly resistant to breakage. Resistant to high pressures and loads.

Maintenance and cleaning

Easy to clean, as traces of food and other residues on the surface cannot penetrate the material, thus offering enhanced hygiene; in most cases, it is sufficient to wipe the surface clean with a damp cloth. Use a microfibre cloth to dust the surface. To wash, use lukewarm water; a detergent may be added according to the dosage recommended by the manufacturer (products containing hydrofluoric acid and its derivatives should be avoided). Rinse with lukewarm water and dry with a clean cloth.

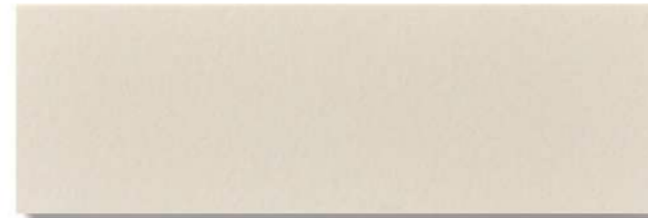

Blanco natural 81
Natural white 81



Gris claro 80
Light grey 80



Gris lava 82
Lava grey 82



Corten 83
Corten 83



Negro 84
Black 84



Gris Ocre 87
Ochre Grey 87



Blanco Roto Veteado 85
Veined Off White 85



Gris Basalto 86
Basalt Grey 86

Polietileno Polyethylene

Es el material utilizado sólo en la colección Weekend. Se presenta en planchas de polietileno de alta densidad fabricadas por extrusión de 2 cm de espesor. Con aditivos UV (protección solar) para que el color no sufra alteraciones. Tanto para los asientos como para tapas de mesas se utilizan planchas de cuatro colores diferentes: blanco, negro, taupe y gris.

Limpieza y mantenimiento

El mantenimiento de estos materiales es mínimo ya que no sufren deterioro con el paso del tiempo. Para limpiar basta con pasarle un paño húmedo o aplicar agua y jabón neutro. Para disimular rayas y defectos superficiales puedes utilizar espráis/ líquidos reparadores que se encuentran en el mercado.

This material is only used in the Weekend collection. The high-density polyethylene is manufactured under an extrusion process and is 2 cm thick. It has UV additives (for solar protection) to ensure that no discolouring takes place. The boards used for both the seats and the table tops are available in four different colours: white, black, taupe and grey.

Maintenance and cleaning

Maintenance of these materials is minimal, since they do not deteriorate over time. To clean them, just wipe with a damp cloth or apply water and a mild soap. To conceal scratches and surface defects, you can use repair sprays / liquids found on the market.



Blanco 90
White 90



Gris 92
Grey 92



Taupe 91



Negro 93
Black 93

Compacto HPL

Es el material de las tapas de las mesas de algunas colecciones. Se trata de tablero compacto de 10 mm de espesor en calidad standard (CGS) termoendurecido a alta presión en formato 4200x1600 mm con el núcleo compuesto de resinas fenólicas y superficies decorativas impregnadas en resinas melamínicas.

Limpieza y mantenimiento

Las superficies de compacto deben limpiarse con regularidad pero no requieren ningún mantenimiento especial, solo un paño húmedo con agua templada o detergente suave. Se pueden usar perfectamente casi todos los productos de limpieza o desinfectantes domésticos siempre y cuando estos no sean abrasivos o altamente alcalinos.

This is the material used for the table tops of some collections. It is a 10-mm thick, compact board in standard quality (CGS), which was thermoset at high pressure in a 4200x1600 mm mould, with a core made of phenolic resins and decorative surfaces that are impregnated with melamine resins.

Maintenance and cleaning

Surfaces made out of HPL should be cleaned regularly and do not require any special maintenance; just wipe with a damp cloth that has been previously soaked in lukewarm water with a gentle detergent. Almost all kinds of cleaning products can be used without any problem, as long as they are not abrasive or highly alkaline.



Negro / Black

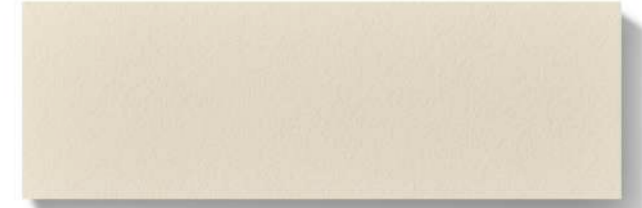

Beige / Beige



Blanco Marmolizado / Marbled White



Blanco Monocolor / Solid White



Madera / Wood



Taupe Monocolor / Solid Taupe

Madera de Teca de Grado A

POINT utiliza madera teca de grado A de origen asiático, procedente de bosques sostenibles de talas controladas. La teca está clasificada como la madera más premium del planeta y, por lo tanto, la más adecuada para los muebles de exterior.

Es extremadamente duradera, estable, impermeable y resistente a la intemperie. Esto se debe a los altos niveles de aceites naturales, dando como resultado una mínima absorción de la humedad y una gran estabilidad. Además, esta madera es muy resistente a los hongos, así como a los ataques de parásitos e insectos.

POINT no aplica ningún "acabado" a nuestra teca. Toda nuestra teca tiene un acabado natural sin ningún tratamiento.

Con el tiempo, los muebles de teca que están al sol, lluvia, humedad, etc. pueden volverse de un color gris plateado. Esto es debido a un proceso de oxidación superficial que protege naturalmente la madera y hace que adquiera una coloración gris plata. Este proceso es estético y no daña la resistencia ni la calidad de la madera.

Dependiendo de las condiciones ambientales, la coloración grisácea natural o el desgaste causado por factores climatológicos pueden notarse después de unas semanas. En climas más secos, la teca tardará varios meses en verse afectada.

La aparición de aceite en la superficie de los muebles de teca es algo normal. Los aceites naturales presentes en la teca son los que la convierten en la mejor madera para muebles de exterior. De hecho, un alto contenido en aceite es un indicador de una madera de alta calidad. Sin estos aceites, la madera no sobreviviría a temperaturas y humedad extrema a la que normalmente están expuestos los muebles de exterior.

Grade-A Teak Wood

POINT uses grade-A Asian teak wood sourced from carefully managed sustainable forests. Teak is considered the most premium wood on Earth and, therefore, the most suitable for outdoor furniture. It is extremely hard-wearing, stable, waterproof and weather-resistant. This is due to its high level of natural oils, resulting in minimal moisture absorption and great stability. This wood is also highly resistant to fungi and attacks by parasites and insects.

At POINT we do not apply any "finish" to our teak. All our teak is untreated and has a natural finish.

Over time, teak furniture that is exposed to sun, rain, humidity, etc. can turn a silver-grey colour. This is due to a process of surface oxidation that naturally protects the wood and gives it a silver-grey hue. This process is merely aesthetic and does not affect the strength or quality of the wood.

Depending on the environmental conditions, this natural greying or weathering may be noticed after a few weeks. In drier climates, it will take several months for the teak to be affected.

The appearance of oil on the surface of teak furniture is normal. It is the natural oils in teak that make it the best wood for outdoor furniture. In fact, a high oil content is an indicator of high-quality wood. Without these oils, the wood would not survive the extreme temperatures and humidity to which outdoor furniture is normally exposed.

The oils and pigments in the surface layer of the teak will gradually begin to wash away the first few times it is exposed to rain. This is a perfectly natural process and it can secrete oil for the first 2 - 3 months, depending on where the furniture is placed.

**Teca
Teak**

Los aceites y pigmentos dentro de la capa superficial de la teca comenzarán a lavarse gradualmente durante la exposición a las primeras lluvias. Este es un proceso natural y el aceite puede desprenderse durante los primeros 2 - 3 meses, según el entorno en el que se coloquen los muebles.

Evite colocar los muebles nuevos de teca en espacios exteriores con pavimentos de piedra porosa de color claro hasta que el proceso de expulsión de aceite haya disminuido. Del mismo modo, evite dejar cojines de colores claros sobre o cerca de los muebles de teca durante este proceso: los tejidos manchados con aceite de teca natural se pueden limpiar con agua y jabón neutro. La cantidad de aceite que sale de la teca durante los primeros meses será mayor y, por lo tanto, es más probable que cause manchas en las superficies y tejidos. Este es un proceso natural que no puede ser previsto.

Debido a que la teca es una madera naturalmente aceitosa, no es adecuado pintar ni barnizar. Cualquier pintura o barniz aplicada no se adherirá correctamente a la superficie y después de un tiempo comenzará a desprenderse. No recomendamos el uso de ningún aceite de madera en la teca. La teca ya es una madera naturalmente "aceitosa" y la adición de más aceite no agrega ninguna protección adicional. Si se incluye aceite de manera adicional, comenzará a crearse moho en las capas superficiales y la teca se volverá negra gradualmente; coloración que sólo puede eliminarse con un lijado agresivo.

Limpieza y Mantenimiento

A pesar de ser un excelente material para los muebles de exterior, su tratamiento y mantenimiento son indispensables para conservar su belleza. Si usted quiere mantener el color plateado natural, POINT recomienda el uso del TEAK CLEANER para limpiar y abrillantar la madera. Para mantener la teca con el mismo aspecto que tiene cuando está recién sacada de la caja, use primero el limpiador y abrillantador TEAK CLEANER para restaurar el color y aplique, posteriormente, el protector TEAK PROTECTOR EcoSafe para mantener y conservar el marrón dorado durante más tiempo. Este producto no es un aceite y está elaborado a base de agua, sin disolventes. Ninguno de estos dos productos afecta a la resistencia y longevidad de los muebles, únicamente a su apariencia.

Do not place new teak furniture on light coloured porous stone patio surfaces until the oil secretion process has decreased somewhat. Similarly, avoid leaving cushions covered with light coloured fabrics on or near teak furniture during this process: fabric stained with natural teak oil can be cleaned with neutral soap and water. The amount of oil that comes out of the teak will be greater during the first few months and, therefore, it is more likely to stain surfaces and fabrics. This is a natural process that cannot be foreseen.

Wasps can occasionally attack the teak surface to make their nests, usually in the spring and early summer. There is no way to prevent this from happening, other than by removing their nests and scaring the wasps away.

Despite being an excellent material for outdoor furniture, its treatment and maintenance are essential to preserve its beauty.

If you want to keep the natural silver colour, POINT recommends using the TEAK CLEANER to clean and polish the wood. To keep the teak looking like it did when it was new, first use the TEAK CLEANER to clean and polish and to restore the colour, then apply EcoSafe TEAK PROTECTOR to maintain and preserve its golden brown colour for longer. This is not an oil; it is a water-based, solvent-free product. Neither of the two products affects the strength and longevity of the furniture, only its appearance.

Because teak is a naturally oily wood, it should not be painted or varnished. Any paint or varnish applied will not adhere properly to the surface and will soon begin to peel. We do not recommend using any wood oil on teak. Teak is already a naturally "oily" wood and the addition of more oil does not confer any additional protection. If oil is added, mould will begin to build up in the surface layers and the teak will gradually turn black, which can only be removed by aggressive sanding.



Teca
Teak



**TEAK CLEANER****Modo de empleo:**

1. Antes de emplear el TEAK CLEANER, se debe utilizar una protección para los ojos y guantes de goma. Antes de empezar proteja la superficie en donde se va a trabajar.
2. Primero mojar el mueble con agua.
3. Agite el TEAK CLEANER antes de usar.
4. Aplique el TEAK CLEANER con un paño suave o una esponja. Dejar penetrar durante 3 minutos.
5. Cepille el mueble para limpiarlo con una almohadilla de fregar en dirección al vetado.
6. Lave bien el mueble con agua.
7. Para un color prolongado, deje secar el mueble y trátelo con TEAK PROTECTOR.

TEAK CLEANER**Directions for use:**

1. Before using the TEAK CLEANER, put on eye protection and rubber gloves. Before you start, protect the surface where you are going to work.
2. First wet the furniture with water.
3. Shake the TEAK CLEANER before use.
4. Apply the TEAK CLEANER with a soft cloth or a sponge. Allow to penetrate for 3 minutes.
5. Use a scouring pad to clean the furniture, brushing it in the direction of the wood's grain.
6. Wash the furniture thoroughly with water.
7. For long-lasting colour, let the furniture dry and treat it with the TEAK PROTECTOR.

**TEAK PROTECTOR****¿Por qué es mucho mejor que el TEAK SELLADOR?**

1. Mantiene el color marrón dorado de la teca durante más tiempo:
 - Hasta 4 veces más que el aceite de teca.
 - Hasta el doble de largo que los selladores de teca.
2. Es respetuoso con el medio ambiente porque es 100% con base de agua. Sin humos tóxicos. No es inflamable. EcoSafe.
3. Es rápido y fácil de aplicar.
4. No es un aceite, no es grasiento.
5. Es resistente al moho y evita manchas negras en la teca.

Instrucciones de uso:

1. Antes de utilizar el TEAK PROTECTOR se debe utilizar protección en los ojos y guantes de goma. Cubra el suelo debajo de su área de trabajo antes de comenzar.
2. La teca gris o la teca tratada con aceite de teca deben limpiarse primero con TEAK CLEANER.
3. Teca nueva: limpie con TEAK CLEANER para eliminar algunos de los aceites naturales de la teca o también puede dejar a la intemperie durante 2 semanas en el exterior antes del tratamiento.
4. Si la madera limpia está áspera, lijar ligeramente antes de tratar con TEAK PROTECTOR. Asegúrese de que la teca esté 100% seca y sin de polvo.
5. Agitar y remover el TEAK PROTECTOR al menos un minuto antes de usar. Una agitación insuficiente puede provocar un desgaste desigual.
6. Le sugerimos que pruebe el TEAK PROTECTOR en un área pequeña primero (por ejemplo, en la parte posterior de una pata del mueble) para juzgar si el color cumple con sus expectativas.
7. Aplicar una capa muy fina de TEAK PROTECTOR uniformemente sobre el mueble con un paño sin polvo. Aplicar una segunda capa muy fina después de 30 minutos de secado.
8. Se recomienda tratar sus muebles con TEAK PROTECTOR al menos una vez al año.

TEAK PROTECTOR**Why is it so much better than TEAK OIL SEALER:**

1. It maintains the light-brown colour of teak for a longer time:
 - Up to 4 times longer than teak oil.
 - Up to twice as long as teak sealers.
2. It is environment-friendly because it is 100% water-based; no toxic fumes; non flammable; EcoSafe.
3. It is fast and easy to apply.
4. It is not an oil, it is not greasy: clothes stay clean.
5. It is resistant to mould and prevents black spots on the teak.

Instructions for use:

1. Before using the TEAK PROTECTOR, put on eye protection and rubber gloves. Before you start, protect the surface where you are going to work.
2. Grey teak or teak treated with teak oil must first be cleaned with TEAK CLEANER.
3. In the case of new teak, first clean it with our TEAK CLEANER to remove some of the natural teak oils (or weather for 2 weeks outside before treatment).
4. If cleaned wood feels rough, sand it lightly before treating it with the Protector. Make sure the teak is completely dry and free from dust.
5. Shake and stir the TEAK PROTECTOR for at least a minute before use. Insufficient shaking can lead to uneven weathering.
6. We suggest you try the TEAK PROTECTOR on a small area first (e.g. the back of a leg) to ensure that the colour meets your expectations.
7. Apply a very thin layer of TEAK PROTECTOR evenly over the furniture with a dust-free cloth. Apply a second very thin coat after leaving to dry for 30 minutes.
8. We recommend that you treat your furniture with TEAK PROTECTOR at least once a year.

Teca Weathered Weathered Teak

POINT ofrece dos tipos de acabado en sus maderas de teca, uno sin tratamiento, totalmente natural en el que el material envejece adquiriendo una hermosa pátina gris. Y, otro –weathered– en el que la madera se somete a un proceso sostenible de envejecimiento, que consiste en erosionar la veta de la madera cepillándola repetidas veces totalmente a mano hasta conseguir una textura más rústica de la veta y se le aplica un tratado con base al agua ecológico que consigue este característico efecto envejecido que adquiere la teca a la intemperie.

Este tratamiento de madera envejecida, se va desprendiendo con la exposición a los elementos. Así, la teca natural va quedando expuesta y tomando la tonalidad gris característica. El ritmo de envejecimiento del acabado varía en función del clima, la exposición y la dedicación al cuidado y mantenimiento. El proceso de envejecimiento se puede acelerar, voluntariamente, con solo dejar los muebles sin tratar o sin cubrir.

POINT offers two types of finish on its teak woods. One is untreated and completely natural, where the material takes on a beautiful grey patina as it ages. The other is weathered, where the wood undergoes a sustainable ageing process that consists of eroding the grain of the wood by repeatedly brushing it by hand to give the grain a more rustic texture. Then an ecological water-based treatment is applied to achieve this characteristic weathered look that teak takes on when exposed to the elements.

This weathered wood treatment gradually fades with exposure to the elements, leaving the natural teak exposed so that it takes on the characteristic grey tone. The rate at which the finish ages varies according to climate, exposure, and care and maintenance. The ageing process can be accelerated voluntarily by simply leaving the furniture untreated or uncovered.



Teca Weathered / Weathered Teak

Funda de cubrir Protective cover

En POINT recomendamos proteger los muebles de exterior con medidas simples y mejorar así su durabilidad. Para ello, creamos la Protective Cover, una funda protectora especial, disponible en color beige, hecha de poliéster con lacado acrílico. Es resistente al agua y cuenta con un tratamiento fungicida en el interior. Además, es repelente a la suciedad y resistente al frío, al calor y a la intemperie.

Cada pieza cuenta con su propia funda. Además, tiene un cordón que permite ajustar la funda al mueble, alrededor de la base, para que el viento no pueda levantarla.

Para obtener mejores resultados, es conveniente que los muebles, cojines y cuadranes estén secos antes de cubrirlos para evitar humedad y manchas de moho.

At POINT we recommend simple measures to protect outdoor furniture and make it more durable. For this purpose, we created the Protective Cover, a special protective sheet, available in beige and made from polyester with acrylic lacquer. It is waterproof and treated with a fungicide on the inside. It also repels dirt and is heat, cold and weather resistant.

Each piece comes with its own cover. It also includes a tie so you can adjust the cover to the furniture around the base to secure it against the wind.

For the best results, the furniture and cushions should be dry before they are covered in order to avoid moisture and mould stains.



LETTER OF WARRANTY

Point, S.L. gives a 3-year guarantee for all its outdoor products. This guarantee covers all damage or material defects detected during this period. POINT also provides a 5-year guarantee covering the fabrics used on the furniture.

To be effective, this guarantee must be used under the parameters of "normal use". Damage caused by vandalism, incorrect use or carelessness are excluded. It also excludes the discolouration of teak wood, as this is a natural process of furniture made from teak. Please check the [Maintenance & Cleaning manual on our website](#).

The guarantee comes into effect the moment the buyer takes possession of the products. Damage due to inadequate storage after this moment will be the buyer's responsibility.



Francisco Pons García
Export Manager

CARTA DE GARANTÍA

Point, S.L. ofrece una garantía de 3 años para todos sus productos de exterior. Esta garantía cubre todos los daños o defectos materiales ocasionados durante este período. POINT también ofrece una garantía de 5 años que cubre las telas utilizadas en los muebles.

Para que sea eficaz, esta garantía debe utilizarse bajo los parámetros de "uso normal". Quedan excluidos los daños causados por actos vandálicos, uso incorrecto o descuido. También se excluye la decoloración de la madera de teca, ya que se trata de un proceso natural de los muebles hechos de teca. Para más información consulte el [manual de mantenimiento y limpieza en nuestra web](#).

La garantía entra en vigor en el momento en que el comprador toma posesión de los productos. Los daños debidos a un almacenamiento inadecuado después de este momento será responsabilidad del comprador.



Francisco Pons García
Export Manager

PROJECTS

CONTRACT BOOK

PROYECTOS

EUROPE

HILTON TALLIN | TALLIN | ESTONIA

MGALLERY GRAND HOTEL CABOURG BY ACCOR | CABOURG | FRANCE

5* SHANGRI-LA HOTEL | PARIS | FRANCE

GREAT JOHN STREET HOTEL | MANCHESTER | UNITED KINGDOM

STEIGENBERGER HERINSDOR | GERMANY

HYATT REGENCY HOTEL DUSSELDORF | DUSSELDORF | GERMANY

STEIGENBERGER ALPENKONIG | AUSTRIA

HERMITAGE MUSEUM HOTEL | SAINT PETERSBURG | RUSSIA

MARRIOTT BASHERON HOTEL | BAKU | AZERBAIJAN

BLUE PALACE RESORT CRETE | CRETE | GREECE

POMEGRANATE WELLNESS SPA HOTEL | HALKIDIKI | GRECE

ALDEMAR OLYMPIAN VILLAGE HOTEL | PELLOPONESSE | GRECE

ROBINSON CLUB KILLINI BEACH | PELLOPONESSE | GRECE

GRECOTEL LAKOPETRA BEACH | PELLOPONESSE | GRECE

GREKOTEL MANDOLA ROSA | PELLOPONESSE | GRECE

GRAN MELIÁ | ROME | ITALY

VILLA ROMAZZINO STARWOOD HOTELS | SARDINYA | ITALY

HOTEL ABI D'ORU | SARDINYA | ITALY

ADOLFO DA QUINTA | FARO | PORTUGAL

THE CLIFF BAY FUNCHAL | MADEIRA | PORTUGAL

PORTO MARE HOTEL FUNCHAL | MADEIRA | PORTUGAL

HOTEL VILAMONTE | MONCARAPACHO | PORTUGAL

HOTEL FALEISA | PRAIA DE FALEISA | PORTUGAL

FOUR SEASONS FAIRWAYS | QUINTANA DO LAGO | PORTUGAL

HOTEL QUINTA DO LAGO | QUINTA DO LAGO | PORTUGAL

ESTALAGEM QUINTA JACINTA | VALE DO LOBO | ALMANCIL | PORTUGAL

MONTEREY HOTEL | VILANOVA DE CA CELA | PORTUGAL

HOTEL CATALONIA PLAZA | BARCELONA | SPAIN

BARCELONA GOLF BARCELÓ | BARCELONA | SPAIN

EMPORDÀ HOUSE | GIRONA | SPAIN

MONASTERIO DE VALBUENA, HOTEL & SPA | VALLADOLID | SPAIN

CATALONIA HOTEL DUQUES DE VERGARA | MADRID | SPAIN

HOTEL WELLINGTON | MADRID | SPAIN

RESTAURANTE EL INVERNADERO DE LOS PEÑOTES | MADRID | SPAIN

MARRIOTT ESTE PONA | MÁLAGA | SPAIN

ALEYS A HOTEL | MÁLAGA | SPAIN

HOTEL MARBELLA CLUB | MARBELLA | SPAIN

MARRIOTT | MARBELLA | SPAIN

PARADOR NACIONAL | TOLEDO | SPAIN

PARADOR NACIONAL | SEGOVIA | SPAIN

LAS ARENAS | VALENCIA | SPAIN

MARINA BEACH CLUB | VALENCIA | SPAIN

PARADOR NACIONAL | JÁVEA | ALICANTE | SPAIN

HOTEL SHERATON REAL DE FAULA | BENIDORM | ALICANTE | SPAIN

HOTEL WESTIN REAL DE FAULA | BENIDORM | ALICANTE | SPAIN

GRAN HOTEL SOL Y MAR | CALPE | ALICANTE | SPAIN

GRAN HOTEL SHERATON | FUERTEVENTURA | CANARY ISLANDS | SPAIN

HOTEL ATLANTIS BAHIA REAL | FUERTEVENTURA | CANARY ISLANDS | SPAIN

HOTEL ELBA PALACE GOLF | FUERTEVENTURA | CANARY ISLANDS | SPAIN

HOTEL KEMPINSKI ATLANTIS BAHIA REAL | FUERTEVENTURA | CANARY ISLANDS | SPAIN

ANFI BEACH CLUB | GRAN CANARIA | CANARY ISLANDS | SPAIN

DUNAS DON GREGORI | GRAN CANARIA | CANARY ISLANDS | SPAIN

GLORIA PALACE AMADORES | GRAN CANARIA | CANARY ISLANDS | SPAIN

HOTEL LA PALMA RESORT | LA PALMA | CANARY ISLANDS | SPAIN

H10 RUBICÓN PALACE | LANZAROTE | CANARY ISLANDS | SPAIN

IBEROSTAR LA BOCAINA | LANZAROTE | CANARY ISLANDS | SPAIN

GRAN HOTEL ANTHELEIA PARK | TENERIFE | CANARY ISLANDS | SPAIN

GRAN HOTEL BAHIA DEL DUQUE RESORTS | TENERIFE | CANARY ISLANDS | SPAIN

HOTEL JARDÍN TROPICAL | TENERIFE | CANARY ISLANDS | SPAIN

MELIÁ BAHIA DEL DUQUE RESORT | TENERIFE | CANARY ISLANDS | SPAIN

HOTEL THE ONE | IBIZA | SPAIN

GRUPOHOTEL IMPERIO PLAYA | IBIZA | SPAIN

HOTEL DORINT SOFITEL | MAJORCA | SPAIN

LA QUINTA RESORT HOTEL & SPA | MENORCA | SPAIN

ARTHUR'S RIVE GAUCHE RESTAURANT | SWITZERLAND

HOTEL ASCOVILLA | ASCONA | SWITZERLAND

BUDAPEST MARRIOTT HOTEL | BUDAPEST | HUNGARY

PULLMANTUR GROUP | INTERNATIONAL CRUISES

RICARD CAMARENA RESTAURANT | VALENCIA | SPAIN

PLETA DE MAR HOTEL | MAJORCA | SPAIN

SCHWAIGER XINO'S RESTAURANT | MAJORCA | SPAIN

IBIZA GRAN HOTEL | IBIZA | SPAIN

NOBU HOTEL | IBIZA | SPAIN

AMÀRE MARBELLA BEACH HOTEL | MARBELLA | SPAIN

FUERTE HOTEL | MARBELLA | SPAIN

MARAÚ BEACH CLUB | ALMERÍA | SPAIN

MOONEN SOFIA 42M YACHT | THE NETHERLANDS

GLORIA VERDE RESORTS & SELECT VILLAS | BELEK | TURKEY

GLORIA SERENITY | BELEK | TURKEY

GRIDA VILLAGE RESORT | BELEK | TURKEY

HOTEL KEMPINSKI BARBAROS BAY | BODRUM | TURKEY

HOTEL INTERCONTINENTAL | KEMER | TURKEY

FAME RESIDENCE HOTEL | KEMER | TURKEY

SALIMA CLUB HOTEL | KEMER | TURKEY

GRAND HOTEL KILIKYA PALACE | KEMER | TURKEY

MIRACLE RESORT HOTEL | LARA | ANTALYA | TURKEY

RIVA DIVAN EXCLUSIVE HOTEL | LARA | ANTALYA | TURKEY

PALM BEACH HOTEL | SIDE | ANTALYA | TURKEY

4* KING STREET TOWNHOUSE HOTEL | MANCHESTER | UK

CLUB MED VALMOREL | FRANCE

EASTWELL MANOR CHAMPNEYS HOTEL & SPA | UK

HOTEL BARTACCIA | CORSE | FRANCE

HOTEL WESTIN DRAGONARA RESORT | MALTA

JUMEIRAH CARLTON TOWER HOTEL | LONDON | UK

HOTEL IBIS HYÈRES | FRANCE

HOTEL NOVOTEL RESORT LE TOUQUET | LE TOUQUET | FRANCE

HOTEL ALEX | ZURICH | SWITZERLAND

ANTAKYA HILTON MUSEUM HOTEL | ANTAKYA | TURKEY

HOTEL L'IMPERATOR | NÎMES | FRANCE

LILY OF THE VALLEY HOTEL | LA CROIX-VALMER | FRANCE

RESTAURANT LE MARINKA | FRANCE

MAISON ASTOR PARIS, CURIO COLLECTION BY HILTON | PARIS | FRANCE
 THE WESTIN RESORT, COSTA NAVARINO | PILOS | GREECE
 BOHO CLUB | MARBELLA | SPAIN
 DOWNTOWN CAMPER | STOCKHOLM | SWEDEN
 PARADOR DE AIGUABLAVA | GIRONA | SPAIN
 ELOUNDA BEACH HOTEL & VILLAS | CRETE | GREECE
 HOTEL PALACIO SOLECIO | MÁLAGA | SPAIN
 NORIDA BEACH HOTEL | GREECE
 NOVOTEL THALASSA LE TOUQUET | LE TOUQUET | FRANCE
 AKFEN BODRUM LOFT | BODRUM | TURKEY
 ALOFT MADRID GRAN VIA MARRIOTT | MADRID | SPAIN
 MONASTERO SANTA ROSA HOTEL & SPA | AMALFI COAST | ITALY
 SAFRAGELL IBIZA SUITES & SPA | IBIZA | SPAIN
 BODRUM LOFT PROJECT | TURKEY
 LILY OF THE VALLEY HOTEL | SAINT-TROPEZ | FRANCE
 RESTAURANTE RITMO | FORMENTERA | SPAIN
 OASIS MARINA BAY | LAS PALMAS | SPAIN
 ALBERGO GELSOMINO HOTEL | KOS | GREECE
 PELICAN CLUB | ALICANTE | SPAIN
 RADISSON COLLECTION HOTEL | BERLIN | GERMANY
 RADISSON RED | VIENNA | AUSTRIA

AMERICA

TEMAZCAL CANTINA | BOSTON | MA | USA
 THE PEARL HOTEL | ROSEMARY BEACH | FL | USA
 DIPLOMAT RESORT & SPA HOLLYWOOD | CURIO COLLECTION BY HILTON | HOLLYWOOD | FL | USA
 THE RAINBOW ROOM | ROCKEFELLER CENTER | NEW YORK | NY | USA
 W FORT LAUDERDALE HOTEL | FORT LAUDERDALE | FL | USA
 MAISON DUPUY HOTEL | NEW ORLEANS | LA | USA
 RESIDENCE INN SANTA BARBARA GOLETA | CA | USA
 PRIVATE RESIDENCE | AUSTIN | TX | USA
 SIXTY FIVE BAR | ROCKEFELLER CENTER NEW YORK | NY | USA
 TOPPING ROSE HOUSE | NEW YORK | NY | USA
 WAILEA BEACH RESORT MARRIOTT | MAUI | HAWAI
 SANDALS RESORT | MONTEGO BAY | JAMAICA
 SOFITEL CARTAGENA SANTA CLARA | CARTAGENA | COLOMBIA
 RESTAURANTE HARRY SASSON | SANTA TERESA | CARTAGENA | COLOMBIA
 DOUBLE TREE BY HILTON | BOGOTÁ | COLOMBIA
 HOTEL SOLAYA | DOMINICAN REPUBLIC
 CLUB GLOF SAN SALVADOR | SAN SALVADOR | EL SALVADOR
 HILTON PRINCESS SAN PEDRO SULA | HONDURAS
 GRAND RIVIERA PRINCESS | MEXICO
 APARTAMENTOS BLU | ACAPULCO | MEXICO
 IBEROSTAR GRAN HOTEL PLAYA PARAISO | CANCUN | MEXICO
 H10 HACIENDA MAYA | CANCUN | MEXICO
 HILTON LOS CABOS | LOS CABOS | MEXICO
 GRAND LUXXE PUNTA | NUEVO VALLARTA | MEXICO
 THOMPSON PLAYA DEL CARMEN | QUINTANA ROO | MEXICO

THEATRE VIDANTA | CIRQUE DU SOLEI | RIVIERA MAYA | MEXICO
 ROYAL ISABELLA | PUERTO RICO
 RANCHO PUNTA MITA | MEXICO
 SOLAZ RESORT LOS CABOS | SAN JOSÉ DEL CABO | MEXICO
 HYATT REGENCY TRINIDAD | PORT OF SPAIN | TRINIDAD Y TOBAGO
 TEMAZCAL TEQUILA CANTINA | MASSACHUSETTS | USA
 AUSTIN MARRIOTT DOWNTOWN | TEXAS | USA
 RESIDENCES BY ARMANI / CASA | FLORIDA | USA
 FISHER ISLAND CLUB | FLORIDA | USA
 1 HOTEL TORONTO | TORONTO | CANADÁ
 CURIO COLLECTION BY HILTON HUNTSVILLE | ALABAMA | USA
 THE WESTIN TEMPE | ARIZONA | USA
 ALYS BEACH CLUB | FLORIDA | USA
 THE RAY HOTEL F&B DELRAY BEACH | FLORIDA | USA
 THE PEARL HOTEL | FLORIDA | USA
 PETER MILLER LENNOX HOTEL | FLORIDA | USA
 CASEY KEY RESORTS | FLORIDA | USA
 THE KEY CLUB GROOT COCOWALK RESTAURANT | FLORIDA | USA
 BALI HAI BEACH RESORT | FLORIDA | USA
 DESOLATION HOTEL | SOUTH LAKE TAHOE | USA

MIDDLE EAST

HYATT REGENCY | JERUSALEM | ISRAEL
 KEMPINSKI HOTEL | AMMAN | JORDAN
 GRAND PALACE AMMAN | AMMAN | JORDAN
 YOSHI RESTAURANT | AMMAN | JORDAN
 RADISSON BLU | KUWAIT
 REGENCY PALACE | KUWAIT
 LUA RESTAURANT | KUWAIT
 INTERCONTINENTAL DOHA | DOHA | QATAR
 CURIO HOTEL BY HILTON | DOHA | QATAR
 PAMPANO RESTAURANT | DOHA | QATAR
 ST. REGIS SAADIYAT ISLAND | ABU DHABI | UAE
 ST. REGIS CORNICHE | ABU DHABI | UAE
 BOA RESTAURANT | ABU DHABI | UAE
 BLOOM MARRIOTT HOTEL & APPARTMENTS | ABU DHABI | UAE
 ROVE HOTELS | DUBAI | UAE
 RIXOS HOTEL THE PALM | DUBAI | UAE
 PALAZZO VERSACE HOTEL | D1 TOWER | DUBAI | UAE
 THE ADDRESS DOWNTOWN DUBAI | DUBAI | UAE
 LE ROYAL MERIDIEN BEACH RESORTS & SPA | DUBAI | UAE | KEMPINSKI
 THE PALM | DUBAI
 RENAISSANCE | DUBAI | UAE
 MADINAT JUMEIRAH | DUBAI | UAE
 ONE & ONLY THE PALM | DUBAI | UAE
 ONE & ONLY ROYAL MIRAGE | DUBAI | UAE
 SHERATON CREEK | VIVALDI RESTAURANT | DUBAI | UAE
 NOVOTEL AL BARSHA | DUBAI | UAE
 AL HALLAB BAB EL BAHR RESTAURANT | DUBAI | UAE

THE RITZ, CARLTON DUBAI | DUBAI | UAE

FUJAIRAH ROTANA RESORT & SPA | FUJAIRAH | UAE

AL BALEED RESORT BY ANANTARA | OMAN

LA VILLE HOTEL & SUITS CITY WALK | AUTOGRAPH COLLECTION | DUBAI

5* GRAND PLAZA MOVËNPICK MEDIA CITY HOTEL | DUBAI | UAE

SOFITEL DUBAI THE OBELISK | DUBAI | UAE

QASR AL SARAB DESERT RESORT BY ANANTARA | ABU DHABI | UAE

HOTEL INDIGO DUBAI DOWNTOWN | DUBAI | UAE

DUBAI FUTURE FOUNDATION | DUBAI | UAE

ASIA

IBIS DELHI | DELHI | INDIA

IBIS JAIPUR | JAIPUR | INDIA

SHANGRI-LA HOTEL | NANCHANG | CHINA

SHANGRI-LA HOTEL | QUFU | CHINA

RENAISSANCE HARBOUR VIEW HOTEL | HONG KONG | CHINA

SANGHA HOTEL BY OCATAVE | HOTEL A PUBLIC AREA + SUITE | SUZHOU | CHINA

MACAU LEGEND PALACE HOTEL | CHINA

THE REPULSE OF BAY | HONG KONG | CHINA

INTERCONTINENTAL NHA TRANG | VIETNAM

OCEAN SPA TAIYOU NO SATO | JAPAN

SHIRAHAMA COGANOI RESORTS & SPA | JAPAN

HAIMURUBUSHI BEACH HOTEL | KOHAMA | JAPAN

MORINO HOTEL | NIKKON | JAPAN

INTERCONTINENTAL ANA MANZA HOTEL | OKINAWA | JAPAN

MANZA BEACH HOTEL | OSAKA | JAPAN

HATUSHIMA CLUB HOTEL | OSAKA | JAPAN

HATUSHIMA BEACH RESORT | OSAKA | JAPAN

NARUTO HOTEL | TOKYO | JAPAN

PALACE HOTEL TOKYO EVIAN SPA | TOKYO | JAPAN

PARK HABIO SHINJUKU | TOKYO | JAPAN

THE SCARLET HOTEL | SINGAPORE

THE RITZ CARLTON | SINGAPORE

JEJU SHILLA HOTEL | JE-JU DO | SOUTH KOREA

COURTYARD MARRIOTT PANG-YO HOTEL | SEOUL | SOUTH KOREA

PLAZA HOTEL SEOUL | SEOUL | SOUTH KOREA

DAEMYUNG. SONO VILLAGE | HONGCHEON | SOUTH KOREA

BLUE MOUNTAIN COUNTRY CLUB SAGEWOOD HONGCHEON | SOUTH KOREA

5* FOUR SEASONS RESORT THE NAM HAI | HOI AN | VIETNAM

5* WALDORF ASTORIA | ITHAAFUSHI | MALDIVES

HOTEL MANDARIN ORIENTAL | BANGKOK | THAILAND

ABBA RESORTS IZU ZAGYOSOH | SHIZOUKA | JAPAN

HOTEL INTERCONTINENTAL YOKOHAMA | JAPAN

FOUR SEASONS | BANGKOK | THAILAND

SHIMOJISHIMA AIRPORT MIYAKO ISLANDS | OKINAWA | JAPAN

FOUR SEASONS SEOUL HOTEL | SEOUL | SOUTH KOREA

AFRICA

HILTON | ARGEL | ALGERIA

BEANO'S CAFE | EL CAIRO | EGYPT

FOUR POINTS BY SHERATON HOTEL | NAIROBI | KENYA

CABO NEGRO ROYAL GOLF CLUB | TETOUAN | MOROCCO

KIGALI MARRIOTT HOTEL | KIGALI | RWANDA

HOTEL LES DEUX TOURS | MARRAKECH | MOROCCO

FOUR POINTS BY SHERATON | SETIF | ALGERIA

THE G HOTEL | NORTH COAST | EGYPT

ANANTARA TOZEUR RESORT | TOZEUR | TUNISIA

ONE & ONLY GORILLA'S NEST | RWANDA

SOFITEL THALASSA & SPA | AGADIR | MOROCCO

ROYAL GOLF MARRAKECH | MOROCCO

RESTAURANT LA CORNICHE BY PALMERAIE | CASABLANCA | MOROCCO

OCEANIA

RIDGES GOLD COAST | AUSTRALIA

LE MÉRIDIEN TAHITI | FRENCH POLYNESIA

LE MÉRIDIEN BORA BORA | FRENCH POLYNESIA