

# Novelties 2023



**PEROBELL**

# The continuity of a great legacy.

<sup>EN</sup> Perobell continues to perpetuate the greatness of a legacy, and it does so with its second catalog to maintain the same enthusiasm invested in each piece; timeless objects born from a blend of innovation and originality that remain in the collective memory. Over time, these become icons, and it is precisely here where design truly finds its reason for existence: it becomes the property of the people, speaking of the ideas and passions of this company.

Passions that have transcended generations to create objects that become symbols of a journey that has seen beyond the obvious, rich in communicative sensitivity, the primary component to satisfy or implement customer desires, because design can go beyond its function.

Design is not just the functional response to a need. Objects capture our attention because they also trigger in us emotional, playful sensations that are enriched with anthropological value.

Perobell has continued to explore opportunities while respecting the dialectic between practical-utilitarian and aesthetic aspects. An animated debate that resisted trends, creating new needs. They even served as pretexts to build relationships.

Perobell's sofas and armchairs have created an aesthetic universe and a unique language. French sociologist Baudrillard stated, "Objects are present as a system of signs that constitute a true language of communication"; Perobell took the initiative and prominence in stimulating conversations and aesthetic narratives, beyond the declared function of each piece.

At Perobell, the models continue to surpass pure functionality and Bauhaus rigor, and with their "poetic" dimension, they generate iconic objects.

Dario Gagliardini

# La continuidad de un gran legado.

<sup>ES</sup> Y lo hace con su segundo catálogo para continuar con la misma ilusión depositada en cada pieza; objetos atemporales nacidos de una mezcla de innovación y originalidad que permanecen en la memoria colectiva. Con el paso del tiempo estos se convierten en iconos y es precisamente allí donde el diseño encuentra verdaderamente el sentido de existir: pasa a ser propiedad de la gente, hablándole de las ideas y de las pasiones de esta empresa.

Pasiones que han traspasado generaciones para crear objetos que se convierten en símbolos de un camino que ha visto más allá de la evidencia, rico en sensibilidad comunicativa, componente principal para satisfacer o implementar los deseos del cliente, porque el diseño puede ir más allá de su función.

El diseño no es sólo la respuesta funcional a una necesidad. Los objetos captan la nuestra atención porque también desencadenan en nosotros sensaciones afectivas, lúdicas, que se enriquecen con un valor antropológico.

Perobell ha dado continuidad a la explotación de oportunidades, respetando la dialéctica entre los aspectos práctico-utilitarios y estéticos. Un animado debate que resistió a las tendencias, creando nuevas necesidades. Incluso fueron pretextos para crear relaciones.

Los sofás y butacas de Perobell han creado un universo estético y un lenguaje único. El sociólogo francés Baudrillard afirmó que “los objetos están presentes como un sistema de signos que constituyen un verdadero lenguaje de comunicación”; Perobell tomó la iniciativa y el protagonismo al estimular conversaciones y narrativas estéticas, además de la función declarada de cada pieza.

En Perobell los modelos continúan superando la pura funcionalidad y el rigor Bauhausiano y, con su dimensión “poética”, generan objetos icónicos.

Dario Gagliardini

# Arnau Reyna



<sup>EN</sup> Ramón Arnau and Mariola Reyna met studying Architecture in 2003, while finishing this career, their passion for furniture design led them to continue studying Industrial Design together.

They design products that connect with the user and the spaces they inhabit. They start from simple ideas that evolve through the design process. Timeless pieces that are not influenced by passing trends. They believe in design as a strategy, an intangible tool that is a fundamental pillar for companies as a driver of productivity and growth. "Design is not just having a good idea, but a criterion with which to draw the business roadmap. We want to create future design icons"

<sup>ES</sup> Ramón Arnau y Mariola Reyna se conocieron estudiando arquitectura, mientras finalizaban esta carrera, su pasión por el mobiliario les condujo a estudiar diseño industrial juntos.

*Diseñan productos que conectan con el usuario y los espacios que habitan. Empiezan por ideas y conceptos simples que evolucionan durante el proceso de diseño. Piezas atemporales que no están influenciadas por tendencias pasajeras. Creen en el diseño como estrategia, una herramienta intangible como pilar fundamental para las empresas como vehículo de productividad y crecimiento. "El diseño no es sólo tener una buena idea, sino un criterio con el que trazar la hoja de ruta de negocio. Queremos crear futuros iconos del diseño."*

# Lluís Codina



<sup>EN</sup> Lluís Codina's extensive professional background has allowed him to work with leading national and international furniture companies. With multidisciplinary training in different fields of design and new technologies, he began his professional activity more than twenty-five years ago. From communication and graphic design agencies to industrial design and computer graphics, he completes his training and accumulates experience that leads to the creation of projects that define a markedly personal style and character.

<sup>ES</sup> *El extenso bagaje profesional de Lluís Codina le ha permitido trabajar con empresas de mobiliario de primera línea nacional e internacional. De formación pluridisciplinar en diferentes campos del diseño y las nuevas tecnologías, inicia su actividad profesional hace más de veinticinco años. Desde agencias de comunicación y diseño gráfico hasta diseño industrial e infografía, va completando su formación y acumulando experiencia que desemboca en la creación de proyectos que definen un estilo y un carácter marcadamente personal.*

# Francesc Rifé



<sup>EN</sup> Interior and industrial designer, Francesc Rifé (Sant Sadurní d'Anoia, 1969) founded his own studio in Barcelona in 1994. Influenced by minimalism and following a familiar tradition linked to craftsmanship, his work focuses on ways of approaching material honesty, spatial order and geometric proportion.

His work has been widely released in the general press as well as specialized publications and books worldwide. Also, there have been several published books that collect his most outstanding works. Currently, he works as well as leads workshops and conferences.

<sup>ES</sup> Interiorista y diseñador industrial, Francesc Rifé (Sant Sadurní d'Anoia, 1969) funda su estudio en Barcelona en 1994. Influenciado por el minimalismo, y marcado por una historia familiar ligada a la artesanía, articula toda su obra en torno al orden espacial y a la proporción geométrica. También demuestra una especial atracción por los materiales nobles que no le abandonará jamás.

Su trabajo ha sido ampliamente divulgado en prensa generalista así como en publicaciones y libros especializados a nivel nacional e internacional. Asimismo se han editado varios libros que recopilan sus obras más destacadas. Durante años se ha dedicado a la docencia y tiene un papel activo en talleres, congresos y conferencias.

# Gabriel Teixidó



<sup>EN</sup> Industrial designer oblivious to trends, characterized by comfortable and useful designs. More than thirty years in this profession, countless design creations and important awards, which have made him one of the most recognized Spanish designers in the sector.

He trained at the Barcelona School of Applied Arts and Artistic Trades and specialized in product design. Accompanied by an excellent ability to turn his designs into commercial successes, based on the philosophy that each piece is useful, that people feel comfortable with them and that they are helpful in any environment.

<sup>ES</sup> Diseñador industrial ajeno a las modas, se caracteriza por diseños cómodos y útiles. Cuenta con más de treinta años en esta profesión, innumerables creaciones de diseño e importantes premios, que lo han convertido en uno de los diseñadores españoles más reconocidos del sector.

Formado en La Escuela de Artes Aplicadas y Oficios Artísticos de Barcelona y especializado en diseño de producto. Acompañado de una excelente habilidad para convertir sus diseños en éxitos comerciales, basado en la filosofía de que cada pieza sea útil, que las personas se sientan cómodas con ellas y que sean de ayuda en cualquier ambiente.

**COLLECTION**

14	ANDRÉ
20	ARQ
26	LEO
32	LIVIANA
38	MARCEL
46	MARTELL
54	MAO
58	OTTO
62	PALMA
70	SOFIA
76	TEVA
82	TSÉ-TSÉ



# ANDRÉ

by Lluís Codina

EN In André, each facet has been carefully sculpted to gently embrace the body and provide unique geometrically shaped ergonomic support.

ES *En André, cada faceta ha sido cuidadosamente esculpida para abrazar suavemente el cuerpo y proporcionar un apoyo ergonómico de formas geométricas únicas.*









# ARQ

by Arnau Reyna

EN Arq tables are inspired by architecture and geometry, they are the perfect balance between lightness and pure lines.

ES *Las mesas Arq están inspiradas en la arquitectura y la geometría, son el equilibrio perfecto entre ligereza y líneas puras.*







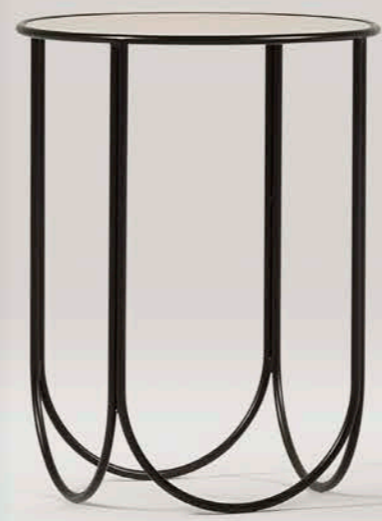



# LEO

by Esther Martínez

EN Leo is a fun collection of four pouffes, all different sizes, that can be combined in different ways providing color and comfort to any space.

ES *Leo es una divertida colección de cuatro pufs de diferentes tamaños, que pueden combinarse de diversas formas para aportar color y comodidad a cualquier espacio.*



PEROBELL  
MADE IN SPAIN









# LIVIANA

by Gabriel Teixidó

EN A visually lightweight armchair thanks to the combination of a metal rod frame that serves as a support, upon which a taut leather piece rests.

ES *Una butaca de gran ligereza visual gracias a la combinación de varilla de metal de su estructura a modo de bastidor sobre el que descansa una pieza de cuero tensado.*









A sophisticated  
and elegant  
solution that  
turns Liviana  
into an instant  
classic.



# MARCEL

by Francesc Rifé

<sup>EN</sup> Marcel's solid and expressive beech wood frame gives it a unique personality. Its clean and defined lines enhance the feeling of comfort in this sofa that perfectly combines rigor with sensitivity. Marcel is the ideal choice for those seeking a unique blend of style and comfort.

<sup>ES</sup> *La sólida y expresiva estructura de madera maciza de haya de Marcel le confiere una personalidad singular. Sus líneas limpias y definidas resaltan la sensación de comodidad en este sofá que combina a la perfección el rigor con la sensibilidad. Marcel es la elección ideal para aquellos que buscan una combinación única de estilo y confort.*













A cozy cushioned interior combined with elegant wooden contours on its outer surface.





# MARTELL

by Arnau Reyna

EN Elegance and comfort combined with contemporary design, transmitting strength and sobriety thanks to its marked horizontal lines.

ES *La elegancia y el confort aunados con el diseño contemporáneo, transmitiendo fuerza y sobriedad gracias a sus marcadas líneas horizontales.*













Whether in residential or contract, this sofa is capable of transforming any space into a cozy and sophisticated place.

# MAO

by Arnau Reyna

EN Mao, a lightweight armchair with a low backrest designed to fit smaller and more casual spaces.

ES *Mao, una butaca ligera y de respaldo bajo para adaptarse a espacios más reducidos y desenfadados.*







# OTTO

by Arnau Reyna

2014 <sup>EN</sup> Inspired by Eastern calligraphy and poetry, these auxiliary tables capture the fluidity and grace of strokes in their minimalist design.

<sup>ES</sup> *Inspiradas por la caligrafía y la poesía de Oriente, estas mesitas auxiliares capturan la fluidez y la gracia de los trazos en su diseño minimalista.*





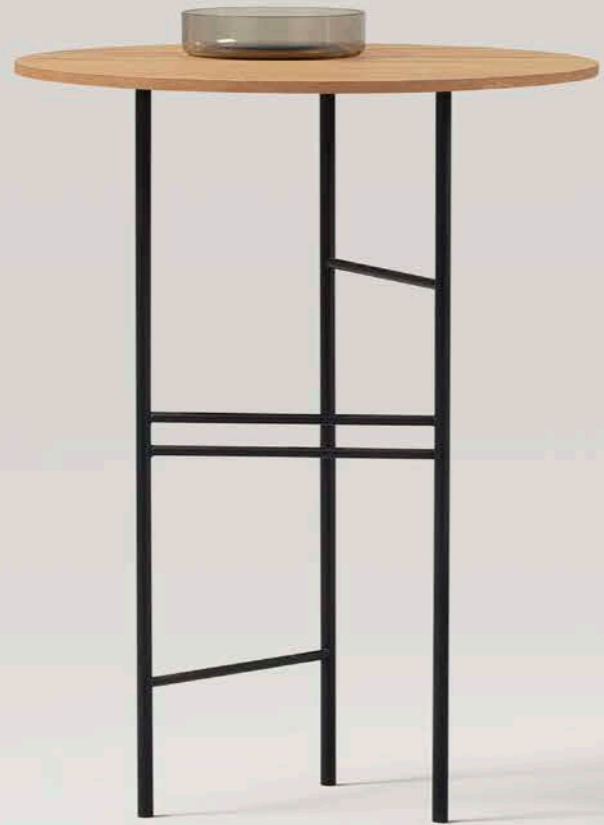



# PALMA

by Arnau Reyna

EN A chair with graphic lines that create a warm and comfortable embrace. Lines that generate a profile that is easily recognizable and full of personality.

ES *Una butaca de líneas gráficas que crean una envolvente cálida y confortable. Líneas que generan un perfil fácilmente reconocible y con mucha personalidad.*









Palma is the  
paradigm of  
comfort and  
beauty in a  
single piece.





# SOFIA

EN Elegance and comfort come together in this design that hides a sofa-bed mechanism capable of satisfying the most demanding. A sofa-bed that offers great comfort and an aesthetic look.

ES *La elegancia y el confort se aunan en este diseño que esconde un mecanismo de sofá cama capaz de satisfacer a los más exigentes. Un sofá-cama que ofrece una gran comodidad y carga estética.*









# TEVA

by Arnau Reyna

EN A reimagining of the Nordic armchair archetype, preserving the warmth of its wooden structure while incorporating new technical solutions in its construction.

ES *Una reformulación del arquetipo de butaca nórdica, conservando la calidez de su estructura de madera, pero aportando nuevas soluciones técnicas en su construcción.*







Teva is a  
commitment  
to the revival of  
craftsmanship  
combined with  
contemporary  
technologies.

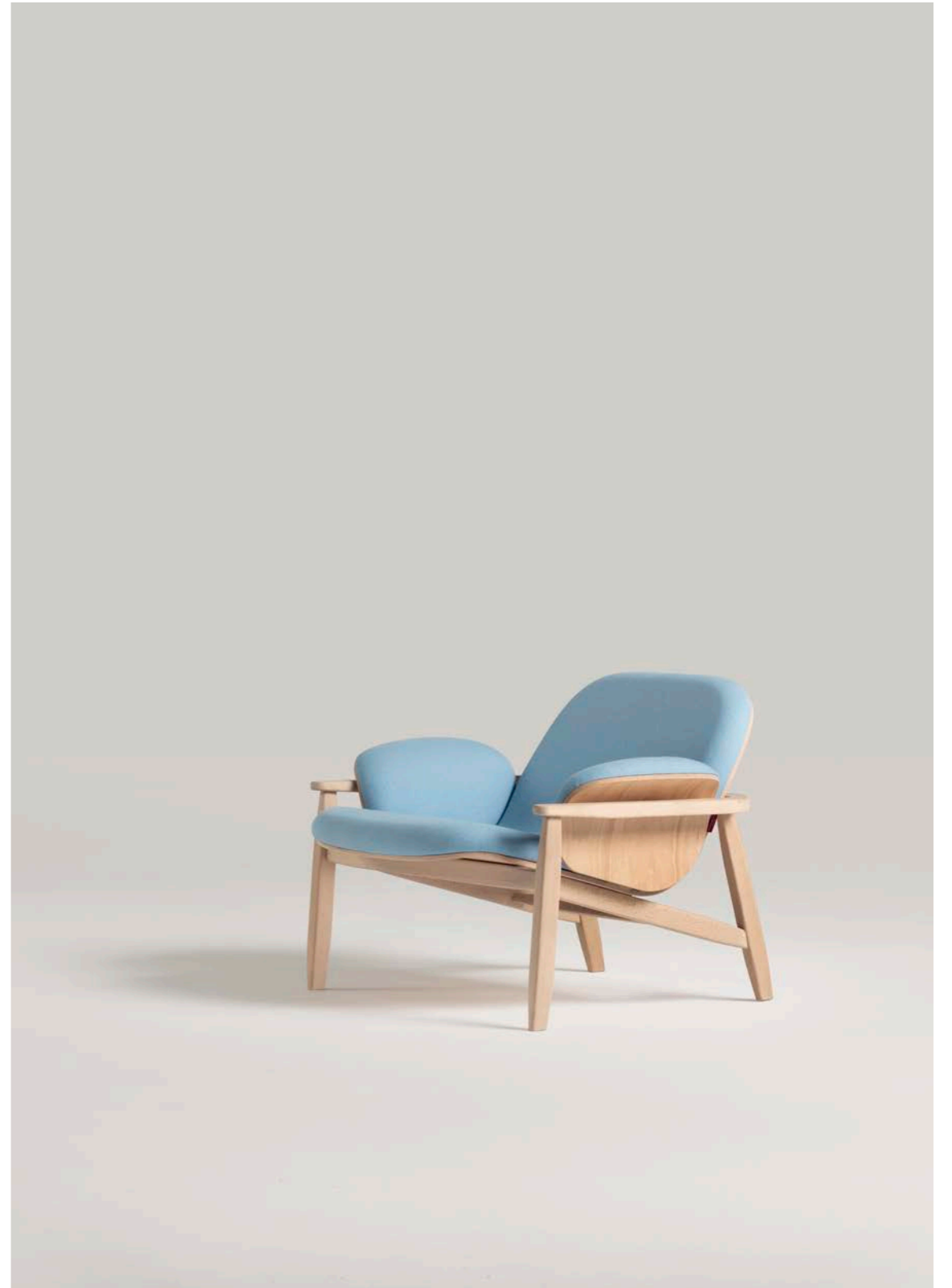



# TSE-TSE

by Gabriel Teixidó

EN Tsé-Tsé stands out with its unmistakable curved line on the backrest. Its unique oval shape seamlessly blends with the soft yet sturdy and plush forms of its seat and backrest, creating an unparalleled experience of comfort and coziness

ES *Tsé-Tsé se distingue por su inconfundible línea curva en la parte trasera. Su singular forma ovalada se fusiona perfectamente con las suaves, pero robustas y mullidas formas de su asiento y respaldo, creando una experiencia de comodidad y confort incomparable.*









EN This collection has been designed to be the centerpiece in residential spaces, where its aesthetic language adds distinctive personality. The perfect combination of curved lines and comfort is embodied in Tsé-Tsé. Furthermore, it offers modularity that allows for a wide range of configurations, and its removable upholstery makes maintenance easy. Tsé-Tsé is the ideal choice for those seeking a balance between style and comfort in their residential environment.

ES *Esta colección ha sido diseñada para ser la pieza central en espacios residenciales donde su lenguaje estético aporta una personalidad distintiva. La combinación perfecta de líneas curvas y confort se traduce en Tsé-Tsé. Además, cuenta con una modulación que permite una amplia variedad de configuraciones y su tapizado desenfundable facilita el mantenimiento. Tsé-Tsé es la elección ideal para aquellos que buscan un equilibrio entre estilo y comodidad en su entorno residencial.*







**TECHNICAL INFO**  
***INFORMACIÓN TÉCNICA***

## ANDRÉ

EN Frame made of reinforced flanders pine wood; seat suspension by means of high-quality elastic belts. Solid metal legs; available finishes: nickel chrome matt or shiny finish, as well as customised RAL varnish (with surcharge). Cushions made of CFC-free polyurethane foam core, covered by a duvet filled with goose feathers. Fixed upholstery for the frame and removable for the cushions. Possibility to combine frame and cushion fabrics.

ES Estructura de madera de pino flandes reforzada; suspensión mediante cinchas elásticas de alta calidad en asiento. Pies metálicos macizos; acabados disponibles: tratamiento níquel/ cromo mate o brillo, así como lacado en RAL cliente (con cargo adicional). Cojines compuestos por alma de espuma de poliuretano libre de CFC y envueltos por edredón de plumas de oca. Estructura tapizada fija y cojines desenfundables. Posibilidad de combinar tapizados en estructura y cojines.

### Four seater sofa S4PXL

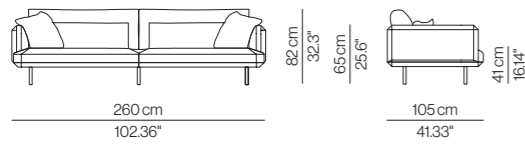

### Four seater sofa S4P

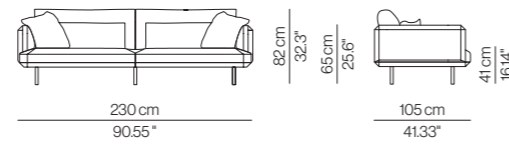

### Three seater sofa S3P

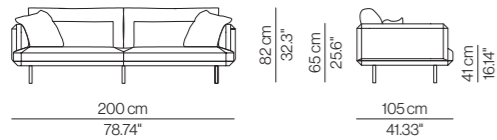

### Two seater sofa S2P

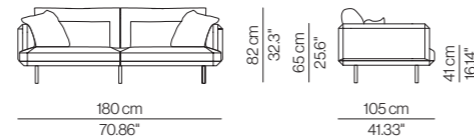

### Armchair B2

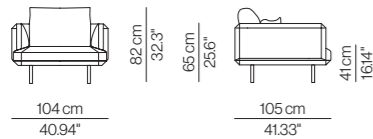

### Armchair B1

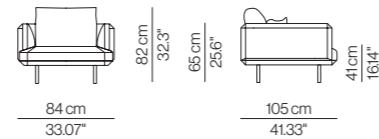

## ARQ

EN Arq tables with solid thermo-lacquered metal legs. DEKTON top in different colours as well as clear glass. (consult finishes available).

ES Mesas Arq de estructura metálica maciza termolacada. Sobre de material DEKTON en diferentes colores así como en vidrio transparente. (Consultar acabados disponibles).

### Arq 80

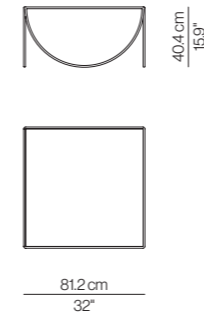

### Arq 90

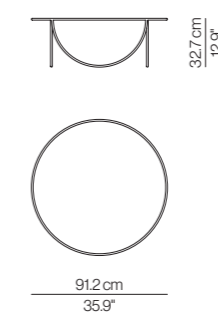

### Arq 60

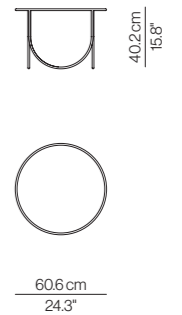

### Arq 46/60

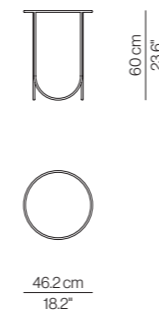

### Arq 46/46

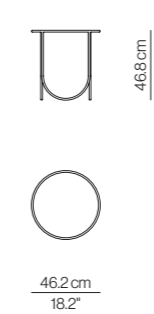

### Arq 46/32

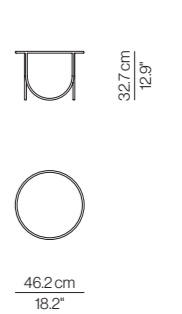



## LEO

EN Frame made of reinforced flanders pine wood; suspension by means of highquality elastic belts. Monoblock upholstery in CFC-free polyurethane foam with different densities, covered by a duvet filled with goose feathers and micro fibres. Removable upholstery, except leather.

ES *Estructura de madera de pino flandes reforzada; suspensión mediante cinchas elásticas de alta calidad. Tapizado monobloque realizado en espuma de poliuretano libre de CFC y varias densidades, cubiertas por edredón de plumas de oca y micro fibras. Tapizado desenfundable, excepto piel.*

### Pouf PF52

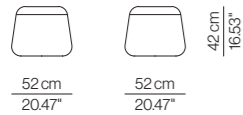

### Pouf PF70

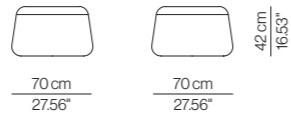

### Pouf PF120

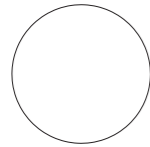

### Pouf PF70x140

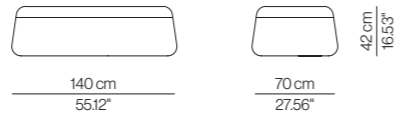

## LIVIANA

EN Metal rod structure. Upholstered with hand-stitched stretch leather cover. Removable cover.

ES *Estructura de varilla metálica. Tapizado con funda de cuero tensado cosido a mano. Desenfundable.*

### Armchair B1

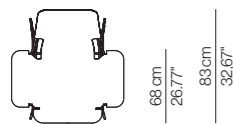
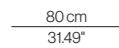

### Stool



## MARCEL

EN The solid beech wood frame comes in two finish options: natural matte water-based varnish and matte black stain. High-quality suspension is achieved with elastic webbing, and the seat, back, and arm cushions are designed with a core of polyurethane foam of varying densities, surrounded by goose feather duvets. Additionally, the seat cushions are removable for easy maintenance, while the upholstery on the frame is fixed for both indoor and outdoor use. This design combines functionality and aesthetics in a high-quality technical ensemble.

ES *Estructura de madera maciza de haya, ofreciendo dos opciones de acabado (barniz mate al agua acabado natural y teñido a negro mate). La suspensión de alta calidad se logra mediante cinchas elásticas, y los cojines de asiento, respaldo y brazos se han diseñado con un núcleo de espuma de poliuretano de diversas densidades, rodeado de edredones de plumas de oca. Además, los cojines de asiento son desenfundables para facilitar el mantenimiento, mientras que el tapizado de la estructura es fijo tanto para uso en interiores como en exteriores. Este diseño combina funcionalidad y estética en un conjunto técnico de alta calidad.*

### Armchair B1

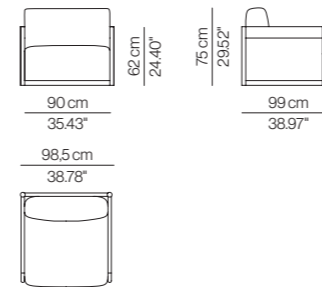

### Two seater sofa S2P

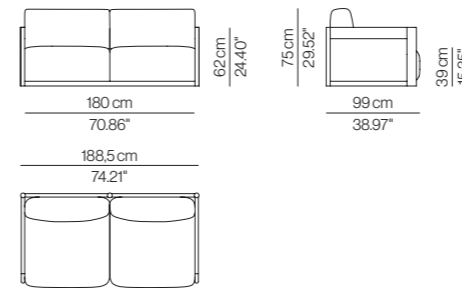

### Pouf PF90

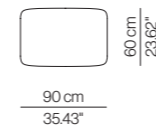

### Love seat

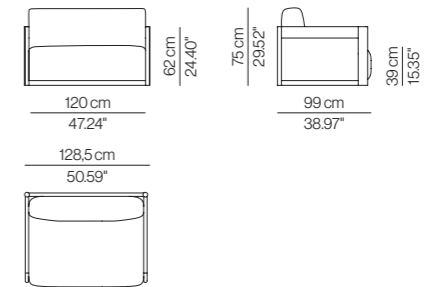

### Three seater sofa S3P

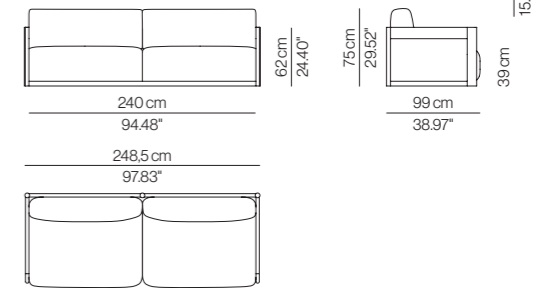

## MARTELL

EN Martell modular sofa, composed of a metal frame with anti-rust treatment. Metal tube feet and laser-cut metal arms. Top quality elastic webbing. Seater and backrests made from a CFC-free polyurethane foam core of different densities, wrapped in a microfiber quilt. Fixed upholstered structure, removable cushions. Feet and arms available in different finishes.

ES *Martell sofá modular, compuesto por un bastidor metálico con tratamiento anti óxido. Pies realizados en tubo metálico y brazos metálicos en corte láser. Suspensión mediante cinchas elásticas de alta calidad. Asientos y respaldos elaborados con alma de espuma de poliuretano de diferentes densidades y libre de CFC, envueltos por edredón de micro fibra. Estructura tapizada fija, cojines desfundables. Pies y brazos disponibles en diferentes acabados.*

### Two seater sofa S2P

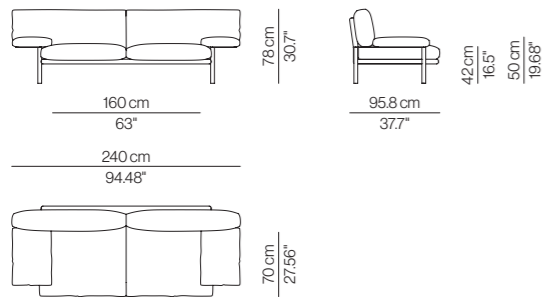

### Three seater sofa S3P

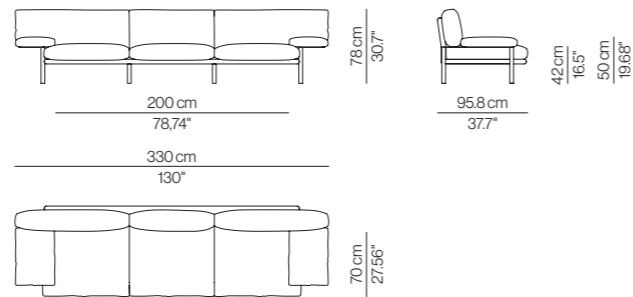

### Side element MDB2

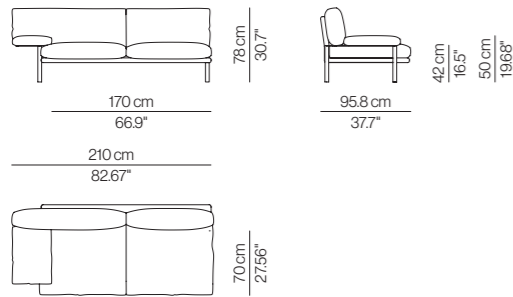

### Corner RI1

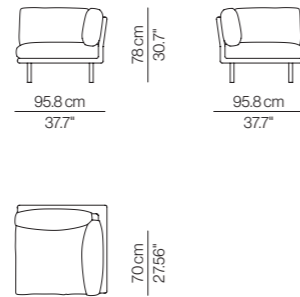

### Central element MD1

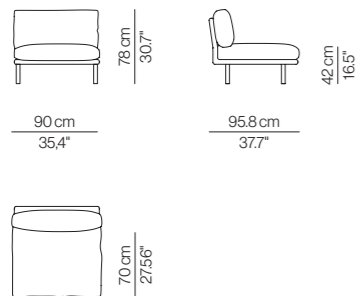

### Central element MD2

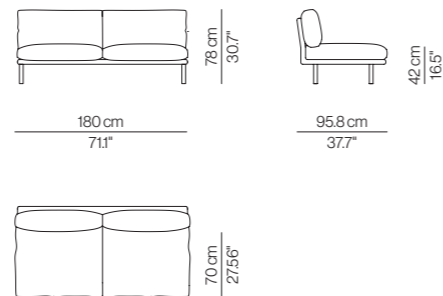

### Pouf PF90

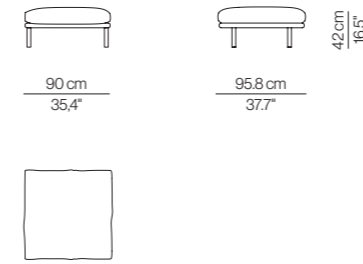

### Pouf PF180

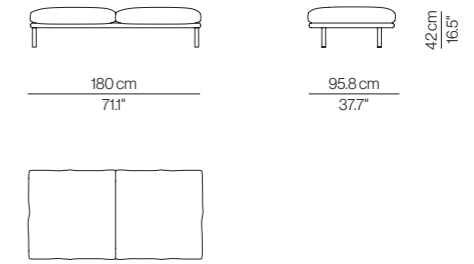

### Chaiselongue CHL1

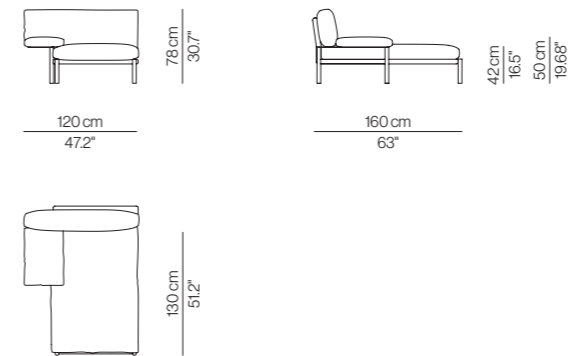

## MAO

EN Frame made of curved plywood board and metal legs. Upholstery in CFC-free polyurethane foam, covered by high-quality cotton. Non-removable upholstery.

ES *Estructura de madera de tablero contrachapado curvado y patas metálicas. Tapizado realizado en espuma de poliuretano libre de CFC recubiertas por boata de alta calidad. Tapizado fijo.*

### Armchair metal legs B1

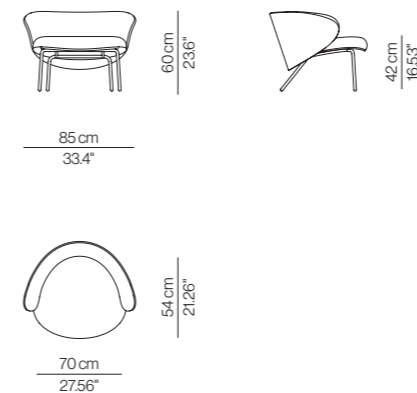

### Swivel armchair BG

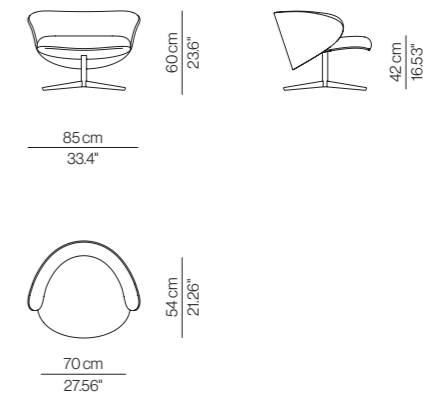



## OTTO

EN Otto tables with solid thermo-lacquered metal legs. DEKTON top in different colours as well as mirror, available in various colours (consult finishes available).

ES Mesas Otto de estructura metálica maciza termo-lacada. Sobre de material DEKTON en diferentes colores así como en espejo disponible en diferentes acabados. (Consultar acabados disponibles).

### Otto 90

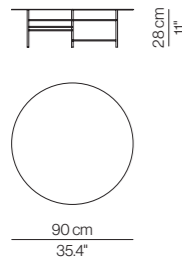

### Otto 55

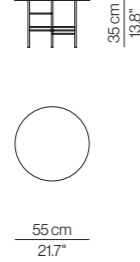

### Otto 40/31

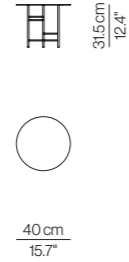

### Otto 40/43

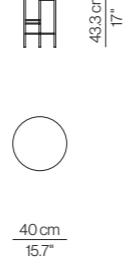

### Otto 40/55

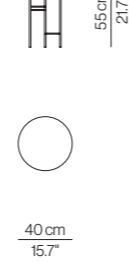

## PALMA

EN Frame made of curved plywood board and metal legs. Upholstery in CFC-free polyurethane foam, covered by high-quality cotton. Non-removable upholstery.

ES Estructura de madera de tablero contrachapado curvado y patas metálicas. Tapizado realizado en espuma de poliuretano libre de CFC recubiertas por boata de alta calidad. Tapizado fijo.

### Armchair metal legs B1

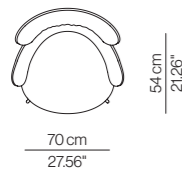
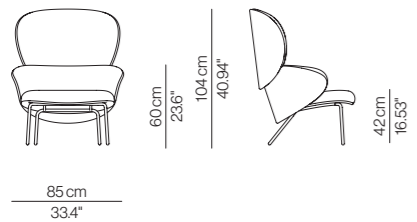

### Swivel armchair BG

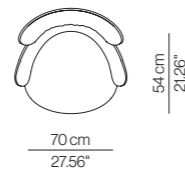
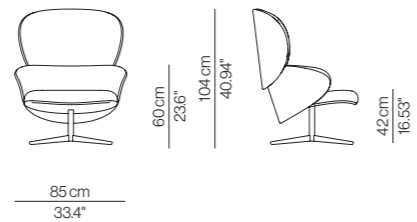

## SOFIA

EN Reinforced Nordic pine wood structure; Suspension by high quality elastic webbing. Solid beech wood feet; Available finishes: natural, black, wenge, cherry, walnut and oak. Seat made with a CFC-free polyurethane foam core of various densities, wrapped in a goose feather and microfiber duvet. Backrests and arm cushions made of goose feathers and microfiber. Completely removable, except in leather. Sofa-bed mechanism: Structure made of cast iron and finished with epoxy paint. Two-fold opening system for a 187\*163\*14h mattress and suspension by straps.

ES Estructura de pino flandes reforzada; suspensión por cinchas elásticas de gran calidad. Pies de haya maciza; acabados: natural, negro, wengué, cerezo, nogal y roble. Asiento con alma de espuma de poliuretano de varias densidades y libre de CFC, envuelto por edredón de plumas de oca y microfibra. Respaldos y cojines de brazo realizados en plumas de oca y microfibra. Totalmente desenfundable, excepto en piel. Mecanismo sofá-cama: Estructura fabricada en hierro fundido y acabado con pintura epoxi. Sistema de apertura de dos pliegues para colchón de 187\*163\*14h y suspensión por cinchas.

### Sofa Bed S4P

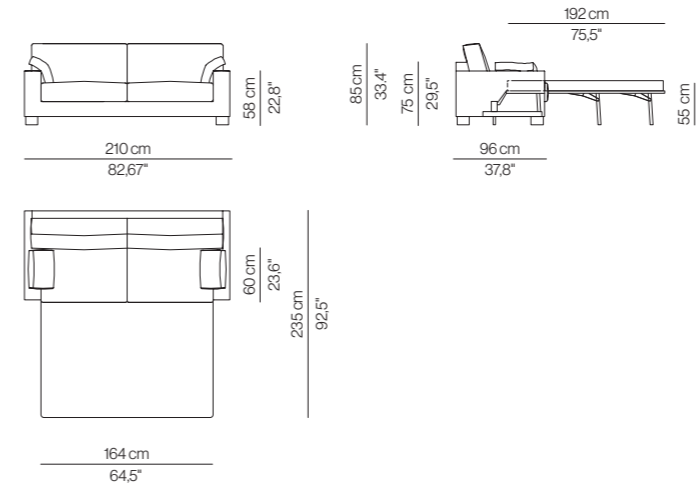

### Armchair Bed B1

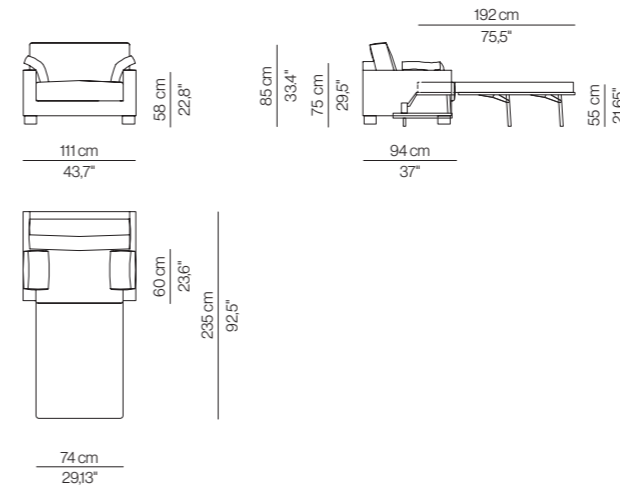

## TEVA

EN Frame made of reinforced beech wood and curved plywood board. Upholstery in CFC-free polyurethane foam, covered by high-quality cotton. Non-removable upholstery. Available in two different backrest heights and non-upholstered version.

ES Estructura de madera de haya reforzada y tablero contrachapado curvado. Tapizado realizado en espuma de poliuretano libre de CFC recubiertas por boata de alta calidad. Tapizado fijo. Disponible en dos alturas de respaldo diferentes y versión sin tapizado.

### Armchair High Backrest Upholstered

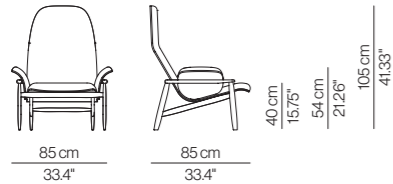

### Armchair High Backrest

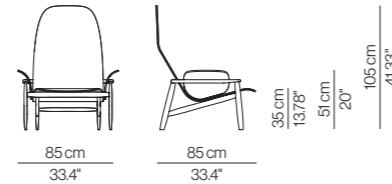

### Armchair Low Backrest Upholstered

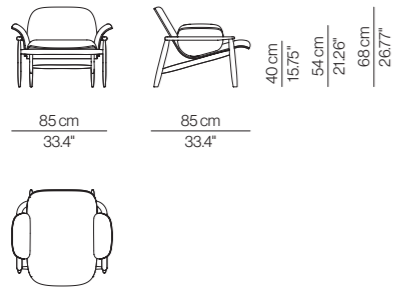

### Armchair Low Backrest

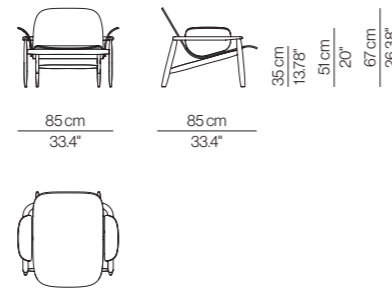

## TSE - TSE

EN Wooden base and reinforced Flanders pine frame. High-quality elastic webbing suspension. Seat, back, and arm cushions composed of CFC-free polyurethane foam core of various densities wrapped in goose feather and microfiber duvet. Fully removable upholstery.

ES Base de madera y estructura de pino flandes reforzada. Suspensión por cinchas elásticas de alta calidad. Cojines de asiento, respaldo y brazos compuestos por alma de espuma de poliuretano libre de CFC de varias densidades envueltas por edredón de plumas de oca y microfibra. Tapizado totalmente desenfundable.

### Side element MDB1

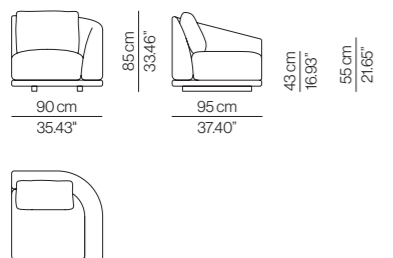

### Side element MDB2

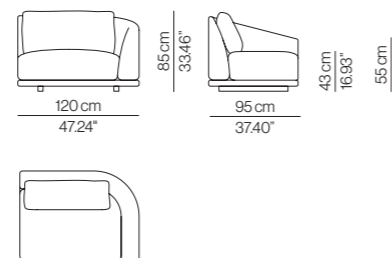

### Central element MDB1

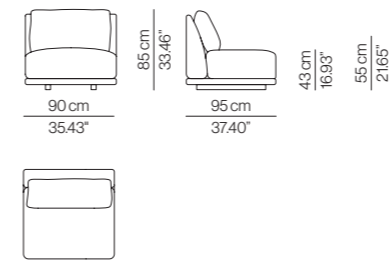

### Central element MDB2

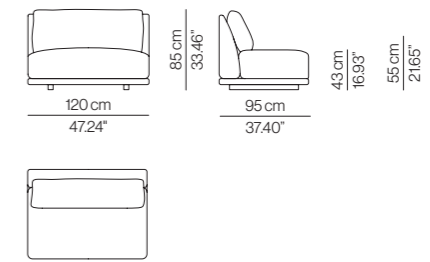

### Chaiselongue CHL1

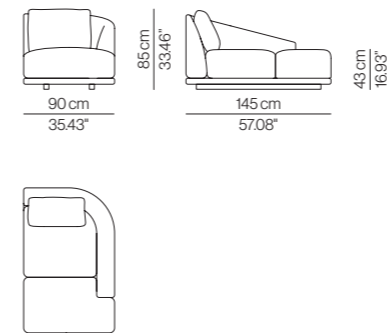

### Chaiselongue CHL2

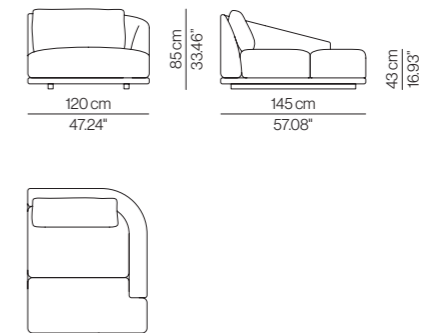

### Pouf PF90

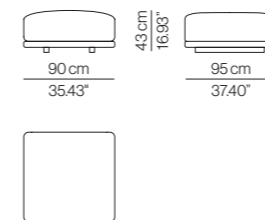

### Central element MDB2

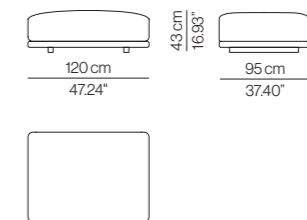

### Table MEC90

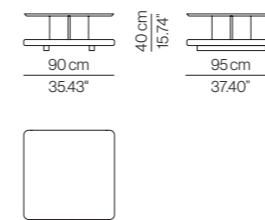

### Table MEC120

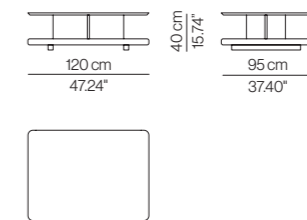



With each catalog, we aim to tell a story that speaks of perseverance, passion, and a love for detail. Discover the rest of collections by Perobell by requesting or downloading the “Classics” catalog from our website [perobell.com](http://perobell.com)

*Con cada catálogo queremos contar una historia que hable de constancia, ilusión y amor al detalle. Descubre el resto de colecciones Perobell solicitando o descargando de nuestra web [perobell.com](http://perobell.com) el catálogo “Classics”*

CLASSICS 1985-2022

AFRIKA  
ARAMIS  
ARMAND  
ATHOS  
BUD  
CHOCOLATE  
CONTINENTAL  
FABRA  
GRAN VÍA  
LIMA  
LOFT  
MONROE  
OBERON  
PREMIER  
PROTOS  
SAM  
SAL Y PIMIENTA  
WALLACE  
ZONE

NOVELTIES 2023

ANDRÉ  
ARQ  
LEO  
LIVIANA  
MARCEL  
MARTELL  
MAO  
OTTO  
PALMA  
SOFIA  
TEVA  
TSÉ-TSÉ

# PEROBELL

Designed by Arnau Reyna Studio  
Photography by Meritxell Arjalaguer

Copyright 2023 Perobell  
All rights reserved / Todos los derechos reservados.

Ildelfons Cerdà, 14 - 08172 Sant Cugat del Vallès / [www.perobell.com](http://www.perobell.com) / email: [comercial@perobell.com](mailto:comercial@perobell.com)



[perobell.com](http://perobell.com)