

# Noon

by Héctor Serrano

REF. MN-NON00

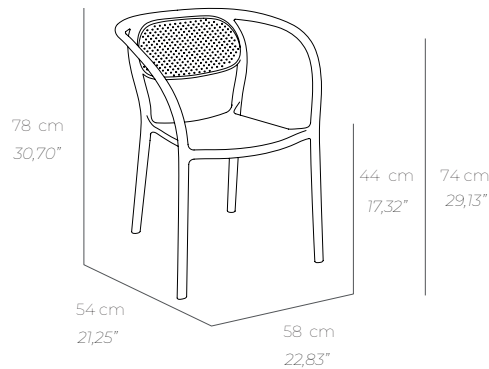

EMPRESA ASOCIADA  
**AIDIMME**  
INSTITUTO TECNOLÓGICO

EN 581-1

EN 581-2

Reg. Design: No. 015020798-0001

## ES

Sillón apilable. Polipropileno reforzado con fibra de vidrio. Inyección por gas. Tacos antideslizantes. Válido para uso en exterior. Protección contra rayos UV. Producto de uso público y doméstico. Usar en superficies estables y planas. Limpiar con agua jabonosa. Evite productos de limpieza agresivos.

## PO

Cadeira empilhável. Polipropileno reforçado com fibra de vidro. Injeção por gás. Tacos antiderrapantes. Válido para uso ao ar livre. Proteção contra os raios UV. Produto de uso público e doméstico. Use em superfícies estáveis e planas. Limpe com água e sabão. Evite produtos de limpeza agressivos.

## EN

Stackable armchair. Fiberglass reinforced polypropylene. Gas injection. Non slip caps. Suitable for outdoor use. UV protection. Public and domestic use product. Use on stable and flat surfaces. Clean with soapy water. Avoid aggressive cleaning products.

## FR

Fauteuil empilable. Polypropylène renforcé avec fibre de verre. Injection par gaz. Embouts antidérapants. Protection UV. Peut être utilisé en extérieur. Produit à usage public et domestique. Utilisez sur des surfaces stables et plates. Nettoyer avec de l'eau savonneuse. Évitez les produits de nettoyage agressifs.

## DETALLES / DETALHES / DETAILS / DÉTAILS

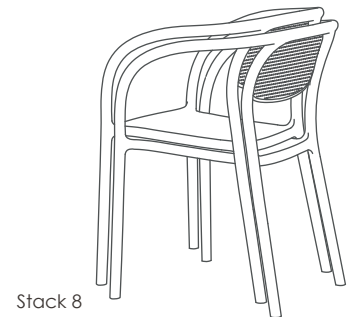

## ACABADOS / ACABAMENTOS / FINISHES / FINITIONS

028X00	024X00	029X00	026X00
Pearl	Taupe	Blue Grey	Terracota

## DATOS LOGÍSTICOS / DADOS LOGÍSTICOS / LOGISTIC DATA / DONNÉES LOGISTIQUES

Weight.	m <sup>3</sup> - f <sup>3</sup> / pallet	U. / Pallet Measurements	Pallet Weight	Truck	Container 20"	Container 40"
4,40 Kg 9,70 lbs	2,4 84,75	36 u. / 120 x 100 x 200 cm 36 u. / 47,24x39,37x78,74"	158,4 Kg 349,21 lbs	936 u.	360 u.	792 u.

Made in Portugal